

# Microeconomic Theory

---

## DECO401



---

**L** OVELY  
**P** ROFESSIONAL  
**U** NIVERSITY

---



# MICROECONOMIC THEORY

Copyright © 2014 Laxmi Publications (P) Ltd.  
All rights reserved

Produced & Printed by  
**LAXMI PUBLICATIONS (P) LTD.**  
113, Golden House, Daryaganj,  
New Delhi-110002  
for  
Lovely Professional University  
Phagwara

## SYLLABUS

### Microeconomics Theory

#### Objectives

- The objective of this course is to acquaint students with the basic structure of Microeconomic Theory. The course will enable students to analyse problems in the key areas using appropriate tools. This will equip the students to take managerial decision in context of microeconomic developments.

Sr. No.	Topic
1	Introduction to Microeconomics, Partial vs. General Equilibrium analysis, Cardinal Utility theory, Ordinal Utility Analysis, Revealed Preference theory
2	Indifference curve analysis, Theory of Demand and elasticity of demand, Recent Developments in theory of Demand
3	<b>Producer Behaviour:</b> Theory of Production, Theory of Cost and Revenue, Production Economics, Traditional and Modern theories of costs: Derivation of Cost functions from Production functions
4	<b>Price and Output Determination – I:</b> Perfect Competition, <b>Price and Output Determination – II</b> Imperfect Competition- Monopoly, Monopolistic Competition
5	<b>Theories of Oligopoly:</b> Definition and nature, Cournot Model , Kinked Demand Curve
6	Bain’s Limit Pricing theory, Marginalism and Average Cost Pricing theory, Baumol’s Sales Maximization hypothesis.
7	<b>Distribution:</b> Classical Theories: Ricardo, Marxian, Macro Theories: Ricardian, Marxian, Kalecki’s theories
8	<b>Welfare Economics:</b> Pareto Optimality conditions in Production, Consumption and Exchange, Market Failure due to externalities in Production, Pigou’s solution to taxes and services, Social Welfare Function
9	<b>General Equilibrium:</b> Partial and General Equilibrium Approaches, Production without Consumption
10	<b>Economics of Uncertainty:</b> Choice in Uncertain Situations, Insurance Choice and Risk, Economics of Information

## CONTENTS

Units	Page No.
1. Introduction to Microeconomics	1
2. The Concept of Equilibrium	11
3. Consumer Theory–Cardinal Utility Analysis	23
4. Ordinal Utility Theory: Indifference Curve Approach	41
5. The Revealed Preference Theory of Demand	83
6. Theory of Demand and Elasticity of Demand	95
7. Recent Developments in Demand Theory	131
8. Production Function and Law of Production	151
9. Theory of Cost and Revenue	171
10. Isoquant Curve	200
11. Concepts of Revenue	220
12. Pricing Under Perfect Competition	235
13. Theory of Monopoly Firm	246
14. Theory of Monopolistic Competition	265
15. Theory of Oligopoly	276
16. Duopoly and Oligopoly: Cournot Model and Kinked Demand Curve	283
17. Bain's Limit Pricing Theory	292
18. Profit Maximization and Full Cost Pricing Theories	301
19. Behavioural and Managerial Theories of the Firm	310
20. Macroeconomic Theories of Distribution	322
21. Macro Theories of Ricardo, Marx and Kailki	328
22. Marginal Conditions of Paretian Optimum	333
23. Market Failure: Meaning and Sources	342
24. Pigovian Welfare Economics and Externalities	354
25. The Social Welfare Function	365
26. General Equilibrium Theory	370
27. Production Versus Consumption	385
28. Economics of Risk and Uncertainty	389
29. Insurance Choice and Risk	400
30. Economics of Information	412

## Unit-1: Introduction to Microeconomics

### CONTENTS

Objectives

Introduction

- 1.1 Microeconomics
- 1.2 Macroeconomics
- 1.3 Distinction between Microeconomics and Macroeconomics
- 1.4 Problems of Interrelation and Integration of the Two Approaches
- 1.5 Summary
- 1.6 Keywords
- 1.7 Review Questions
- 1.8 Further Readings

### Objectives

After studying this unit, students will be able to:

- Know about Microeconomics.
- Study Macroeconomics.
- Explain the importance of Microeconomics.
- Discuss the problems related to Micro and Macroeconomics.

### Introduction

Microeconomics and Macroeconomics are two ways of analyzing the Economic problems. First is related to study of economic individuality while the second is related to study of the whole economical conditions. **Ranger Frisch** was the first person who used the Micro and Macro words in Economics in 1933.



*Example:* We study the co-relation of individual families, individual firms and individual industries in Microeconomics.

## 1.1 Microeconomics

### **Its meaning**

The study of economic activities of persons and the small groups of persons is called Microeconomics. According to **Prof. Boulding**, "This includes the study of particular firms, families, individual prices, labour, income, individual industries and particular things." This makes important relation in distributing the resources in using particular experiments and analyzing the prices. The main sectors among the Microeconomics are: The decision about production balancing of firms and industries, the wages of particular labour work, rice, tea or car etc. According to **Ackley** – "Microeconomics makes relations with the distribution of resources among competitive groups and distribution of total production of firms and industries. It deals with the prices of particular objects and services."

In fact, as **Maurice Dobb** said – Microeconomics is a microscopic study of an economy. This is a source of seeing an economy through microscope so that one can know about the movements of producers and individual consumers and the markets of individual objects. In other words, we study co-relations of an individual family, firms and individual industries in Microeconomics. Thus, economics is the study of aggregates.

### **Its Scope**

"Prices and rate principles, families, firms and industries principles, maximum production and welfare principle are parts of Microeconomics." Thus Microeconomics studies (1) How the resources are distributed in production of objects and services, (2) How these goods and services are distributed among the people, (3) How smoothly they are distributed. While studying the steps of deciding the price of particular goods, Microeconomics observes the total price already given and tries to describe the distribution of those resources for the production of those goods. The distribution of resources for particular goods depends on the prices of production resources of other goods. In other words, the distribution of resources decides, what to produce, how to produce and how much to produce and this depends on prices of goods and services. Thus "Microeconomics is a study of price principle." How it decides the price of the particular goods such as rice, tea, milk, fans and scooter, etc. How the profits of a particular Industry, rate of interest on a principal amount and wages of labours and the revenue of a particular land are decided and how smoothly the distribution of resources is done among the individual producers and consumers? We explain these problems in brief.

Analysis of price determination and allocation of resources are studied in microeconomics in three different conditions (i) Individual consumers and procedures equilibrium, (ii) Single market equilibrium, (iii) Equilibrium in different types of market. Individual consumers and producers cannot affect prices of those products which they buy and sell. A consumer has to face the given prices and he purchases only that quantity of the product which gives him maximum utility. For an individual producer, the input and output prices are given and he produces only that quantity of goods which gives him maximum profit. In markets, prices and quantities of purchasing and selling determine the function of buyers and sellers. From individual demand and supply curve total demand and supply curve are made. Equilibrium between total demand and supply curve determines the price and quantity of purchasing and selling in markets. It applies to both product and factors markets. But relating the assumption of perfect competition market, this analysis can be extended to monopoly, oligopoly and monopolistic competition markets.





Notes Microeconomics is the smallest study of the economy.

## Notes

Vastly, co-relation among different markets is taken into consideration so that all the prices could be determined at a time. Although, it is usually said that microeconomics is related to partial equilibrium analysis which studies equilibrium condition of a person, a firm and an industry, it is also the study of their natural relation and mutual dependence in the economy which comes under the preview of general equilibrium analysis. So microeconomics is the study of mutual interdependence of prices of individual consumers, firms and industries related goods, factor price, their demand and supply and costs.

First, a consumer market in which quantity demand of the product does not depend only on its availability but also on the price of every other product available in the market. In this market, consumers meet with producers to buy the product in which consumers purchase and producers sell the product. Consumer demand of the different goods depends on its own prices and prices of the service, which they provide. In other words; a consumer earns income by selling his produced services and creates demand for the products. The price at which goods are sold depends upon its production costs further, production costs depend upon different services, which are used to produce the goods, their quantities and their remuneration. In this way, supply of goods in the market depends on the cost of production of the firm and price of quantities of their different services.

Second in producer markets or factor market, factors of production are demanded by producers and supplied by consumers. Quantity of factor used for the production of a product depends upon the relation between its price, prices of other factors and prices of goods. Here production meets labourers, capitalists, land owners and owners of other resources. In this market, monetary income is earned by resources' owners who sell them. They are lamely consumers. In this way, microeconomics studies the mutual relation of consumers, producers and owners of resources. In this system, all prices are related to each other. Change in any one price creates disturbance which affects both product and resource market. Inter relation between resources and product market through prices is shown in the Fig 1.1. In this way, macroeconomics is the study of natural interdependence among product price, resource price, their demand supply and cost, which are related to individual consumers, firms and industry.

Besides this, microeconomics also studies how efficiently various resources are distributed between individual consumers and producers. Efficiency of distribution of resources is related to study of welfare economics. It includes the study of efficiency in the consumption, affiance in production and overall efficiency in consumption and production. Efficiency of production and consumption is related to individual welfare and over all efficiency is related to social welfare, welfare of individual consumer is maximized when it could be improved with any redistribution of resources without deteriorating situation of any other individual. An individual producer attains efficiency in production when he is able to increase the production of a particular product by redistribution of resources, without hampering the production of other goods. Overall efficiency which is also known as social welfare or pareto-optimality is related to overall improvement in economic efficiency of society which leads to increase in social welfare of society which leads to increase in social welfare when redistribution of resource results in better condition of society without distributing situation of any individual any redistribution of resources at this level not only lead to overall economic inefficiency but also creates inefficiency of individual consumers and producers. This way microeconomics studies the welfare theory in individual and collective viewpoint.



Notes

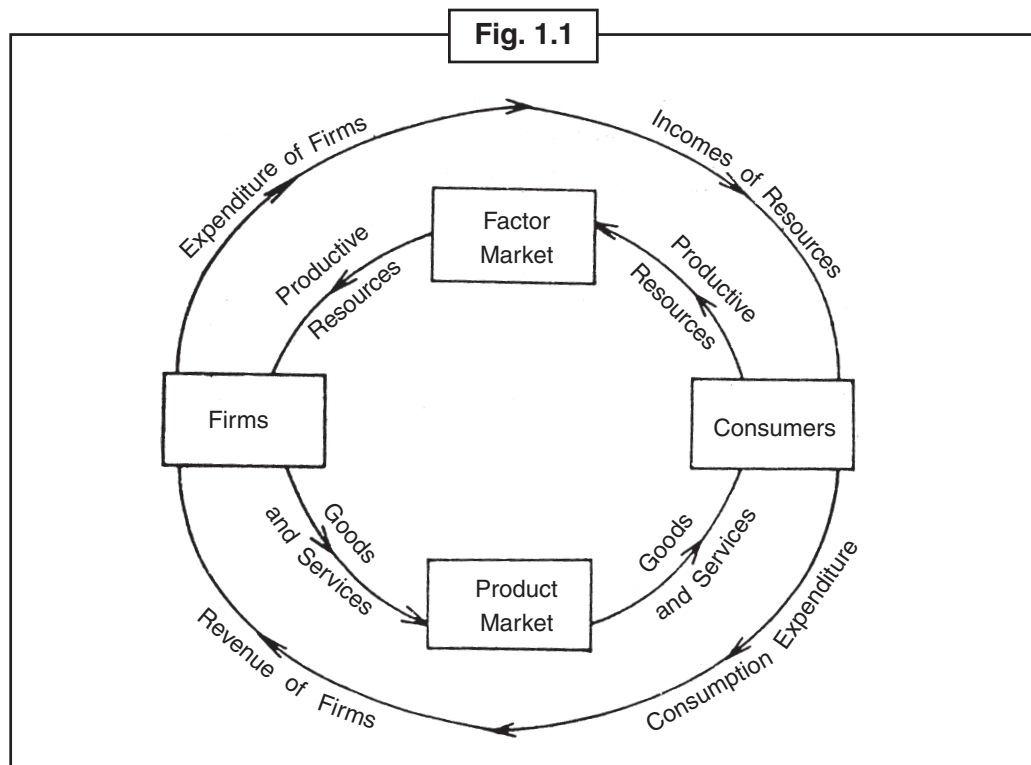

We reach the conclusion that microeconomics deals with the study of price theory, theory of individual family, firm and industry, production theory and welfare theory.

### Importance of Microeconomics

Microeconomics is an important mean in economic analysis which **Keanz** assumes as a necessary part of one's apparatus of thought. It has both theoretical and behavioural importance.

- 1. To understand the working of the economy:** Microeconomics is very important in understanding the working of a free economy. There is no organisation to plan and co-ordinate the economic system in this kind of economy. The decision that how to produce, what to produce, for whom to produce, how to distribute and what to consume, are taken by producers and consumers itself without any external power. It concludes that in centrally planned economy, planning authority cannot achieve proficient working in the absence of free entrepreneurial economy. As **Lerner** has said, "Microeconomics teaches us that complete simple working of the economy is impossible. Modern economy is so complicated that no one centrally planned organisation can get all information and it cannot provide every necessary suggestion for its efficient working."
- 2. To provide tools for economic policies:** Microeconomics provides analytical tools for the valuation of economic policies of states. Price or value system is a tool, which helps in this function. In a mixed economy, state operates many public utility services such as post office, railway, water, electricity, etc. In this economical condition, central, state and regional government do not fix price on profit or loss basis. Further, these prices affect the prices of other goods and services. There are public enterprises too, which are operated on price-profit policy. Prices of goods manufactured by these effect prices of various goods and services of private sectors. Some public enterprises are competitors of private enterprises and thus their pricing policies are based on pricing-system. They cannot charge more price than private sector. Microeconomics helps the government in formulating appropriate pricing policies and their valuation.

3. **Helpful in the efficient employment of resources:** Price theory is related to utilising the rare resources in an efficient manner. The problem which is faced by the present government is especially the distribution of resources. As per this view microeconomic is used by the government for the efficiency of resources and for attending growth with stability.
4. **Helpful to the business executive:** Microeconomics is helpful for the businessman in achieving maximum production with the present resources. With the help of this, he is able to understand the consumer's demand and estimate cost of his products.
5. **Helpful in understanding of some problems of taxation:** Microeconomic is helpful to understand some problems of taxation. It is helpful to explain the prosperous results of a tax. It takes factors of taxation towards optimum level of redistribution. Microeconomics helps in explaining that a tax makes deficiency of social welfare or production charge or sales tax. The deficiency of social welfare happens due to the production charges or sales tax rather than income tax. Microeconomics analysis studies the distribution of tax ratio of sales tax between sellers and consumers.
6. **Helpful in understanding the problems of international trade:** It is used in the field of international trade for determining international trade projects, disequilibrium in balance of payment and foreign exchange rate. Expected demand character ties of each other's products determine the projects from international trade. Disequilibrium in balance of payments means disparity between demand and supply of foreign solvency. In a free market, the deficiency of currencies is fixed on the exchange rate and demand and supply of foreign currency.
7. **To examine the conditions of economic welfare:** Microeconomics can be used to examine the conditions of economic welfare means, "examining subjective satisfaction, which could be received by enjoying individual, goods and services as well as rest". It includes study of welfare economics which defines an ideal economy. As mentioned above, welfare economy is linked with enhancement of social welfare. This is possible only in perfect competition. But, there is always dislocation of resources in monopoly, oligopoly or monopolistic competition and actual production is always less from its optimum level. So there is always wastage of resources. Microeconomics helps in suggesting various ways of eliminating wastage for the maximum social welfare. As **Prof. Learner** states, "We are either related to eliminate or to end most of the wastages in the microeconomics, or with the fact that organised production is not done in the best possible manner because of wasting influence - Microeconomics theory point out the condition of efficiency (i.e. to eliminate every type of inefficiency) and suggests that how to fulfil these conditions. This condition which is called 'Pareto Optimum' condition helps to make comfortable to the living conditions."
8. **The basis for prediction:** According to **Bilas**, microeconomics theory can be used as a basis for prediction. It does not mean that it will provide the ability to tell the future. But it gives the ability to the supervisor to tell the future in conditional manner. The terms are as: if anything happens then we can get a result of an aggregate group. For example we would be able to study the government policies which affect the products and wages and see that how these policies affect the distribution of factors. Microeconomics theory gives us the liberty to state this in conditional manner.
9. **Construction and use of models for actual economic phenomena:** Microeconomics used to create the models to understand the economical structure. As **Bilas** said - "The theoretical way of microeconomics is used to represent the prices by such models and also to understand the distribution of various things. The officer who uses this theory should be able to judge the significance of this problem." **Learner** clarified this by saying - "Microeconomics helps to understand the problem of the very problematic things by various models which looks real in terms of understanding. In this mean time, these models would give the opportunity to the economist to define this as this incident looks real in terms of growth and which can serve personally and socially. This will not only help to clarify the real economical conditions, but also give solutions which look good as well as precise and will also predict to the terms and incidents like this." Thus this is good method to solve the problems.

**Notes**

**Limitations of microeconomics:** In spite of its importance, there are some limitations of Economics, which are discussed below:

1. It depends on the unreal esteem of true employment in economical situation. According to **Kenz**, to adopt true employment is like adopting the situation that there is no problem at all. In this real world, true employment is not a rule but exceptional. Thus, Microeconomics is not a good method for economical analysis.
2. Microeconomics is based on Laissez Faire conditions. But nowadays this theory is not used at all. It is ruled out with the big crises of 1930. So the study of microeconomics seems unreal.
3. Microeconomics deals with fraction and ignores the radical. As **Bolding** states, "It is impossible to define a huge and vast system like economical system as a personal unit." So microeconomics produces a faded and unreal picture of economical system.
4. Various economical problems are not defined by Microeconomics even not identified too. It is not necessary that a rule which applies to a firm, a family or a company is also applicable to a huge economical system too.

**Self Assessment**

**Fill in the blanks:**

1. Microeconomics is an important mean in ..... analysis.
2. Microeconomics helps to understand the problems of ..... .
3. The word 'micro' is taken from Greek word ..... .

**1.2 Macroeconomics**

**Its meaning**

Macroeconomics is the study of aggregate or things related to the entire economy like total employment, unemployment, national income, national production, total investment, total consumption, total saving, total supply, total demand and general pricing, interest rates and cost structure. In other words, macroeconomics scans each other relation, their bonding and their ups and downs. Thus as per **Ecle**, "Macroeconomics deals with major incidents. This deals with the economical experience as an elephant's structure and in spite of checking the bones and hips, it checks the whole size, shapes and structures. It studies the nature of forest and not the nature of trees which make them forest."

Macroeconomics is also known as "theory of income and employment" or "income analysis". Unemployment, economical ups and downs, inflation, instability, motionless, international trade and economical development are studied under macroeconomics. It deals with the reason of unemployment and the various factors of employment. It connects with the business total production, total income and total employment. In pricing factor, it studies the general pricing and its effect. Debit balance in international trade and the problems in foreign help come under macroeconomics. Above all the theory of macroeconomics deals in the study of a nation's total income and its difficulties as well as its ups and downs. At last, it studies the reason, which affects on the growth of an economical structure of a nation.



*Caution* Microeconomics is not able to define many economical conditions.

### 1.3 Distinction between Microeconomics and Macroeconomics

Following are the differences between Microeconomics and Macroeconomics:

'Micro' word came from Greek word 'micros' which means small. Microeconomics deals with humans and a small group of humans. It is the study of exclusive family, firms, companies, things and prices. 'Macro' word is also from Greek word 'macros' which means 'Big'. It deals in a big manner like with nation's capital and not with a person's income, normal price range and not with an individual price, national productivity and not with an individual productivity.



*Did u know?* 'Micro' word is derived from the word 'Micros' and 'Macro' word is derived from the Greek word 'Macros'.

Microeconomics maximizes the use of demand and maximizes the profit over minimum input of supply. On the other hand, the main motto of macroeconomics is purposeful employment, fixed pricing, rise on economical condition and favorable payment balance.

The base of microeconomics is pricing which works with the help of supply and demand. This power helps to equalize the pricing in market. On the other hand, the base of macroeconomics is national income, productivity, employment and general pricing which defines by total demand and total supply.

Microeconomics is based on prudent behaviour of humans. "All things are equal" used in it to define various economical laws. On the other hand, the recognition of macroeconomics deals with the total volume of economical condition and its range, graph of national income and normal life.

#### Self Assessment

##### Multiple choice questions:

4. The efficiency of distribution of factors is related to the study of ..... economics.
  - (a) welfare
  - (b) micro
  - (c) macro
  - (d) social
5. The demand of productive factors comes from ..... .
  - (a) consumers
  - (b) producers
  - (c) pricing
  - (d) owners
6. The relation of price theory relates to ..... use.
  - (a) factors
  - (b) distribution
  - (c) less consuming
  - (d) appointment
7. In the real world, full employment is not real but ..... .
  - (a) unreal
  - (b) exception
  - (c) employment
  - (d) analysis
8. Microeconomics is the key of ..... economical analysis.
  - (a) unreal
  - (b) full
  - (c) exceptional
  - (d) successful

Microeconomics is based on the partial equilibrium, which helps to clarify the constant terms of a person, a firm, a company and a resource. On the other hand, macroeconomics is based on general equilibrium, which helps in studying the various economical conditions and their relations.

In microeconomics, the study of equilibrium terms happens in a specific period. This period does not describe any entity. Thus, microeconomics is a static condition. On the other hand, macroeconomics is based on the time lags, laws of changes and pricing. So it relates to the detailing of things.

The microeconomics is used for wide range of conditions, problems, markets and the different types of associations. It relates to recognition and methodology which helps to get solutions of problems.

**Notes**

In respect of this, microeconomics helps to get practical knowledge of economics where there are less economical problems and their solutions.

Microeconomics and macroeconomics, both are the study of aggregate. But the aggregates are different from each economics. Microeconomics deals with the aggregation of individual family, individual firm and individual companies. For example, the term 'company' adds many firms and things. The demand for shoes can add various families and the supply is also added on various firms. The demand and supply of labour in a region is the recognition of a group." But the study of aggregates is different from micro to macroeconomics. In macroeconomics, the groups used as "addition of whole economy" but in microeconomics, it is not conjugates with an economy but relates to individual firm, family and industry.



Task

Give your opinion on micro and macroeconomics.

## **1.4 Problems of Interrelation and Integration of the Two Approaches**

The differences of micro and macroeconomics are not rigid because their parts effects all the quantities.

**Dependence of microeconomics on macroeconomics:** For example, put the dependencies of macroeconomics on microeconomics, when the demand increases in prosperity, then the demand of individual things also increases. If this is due to the less interest rate, then product demand will also increase. This will increase the demand of a specific labour for the pricing company. If the labour is rigid then the cost of labour will increase. This happens due to increase in the cost of things. Hence the macro economical changes changed the pricing of microeconomics. Thus the shape of income in economical condition, employment production, pricing affects the individual company and firms. Thus this affects the structure of price, production, employment of individual firm and industries in terms of income, production, employment and cost in economics. Take another example, when the production falls in crises, then the production of price falls rather than production of products. So the benefits, employment and job fall mostly in product-industry rather than pricing-product industry.

**Dependence of macroeconomics on microeconomics:** On the other hand, macroeconomical theory also depends on an individual. Whole is made with parts. The national income is an addition of people, firm and company's income general price range is an average of all prices of things and services. The general price is the average of all prices of products and services. Thus the production is an average of whole production of all the units in an economy.

We can put some examples on micro and macroeconomics. If economy concentrates their factors only to the agricultural products then the production of an economy will cut because all other regions will not cover. In an economy, the income and the employment status also depend upon the distribution of income. If there is unequal distribution of income like some rich people get maximum income then the consumer product will have less demand. This will affect profit and invest and production will increase unemployment and at last, there is crisis situation in economy. Thus, the process of studying and analyzing depends on both micro and macroeconomics.

### **Self Assessment**

**State whether the following statements are True/False:**

9. **Regner Frish** was the first man who used the terms Macro and Micro in economics in 1933.
10. The study of small individual groups as well as individuals is macroeconomics.

11. Microeconomics is the study of pricing law.

12. The consumption and productivity is based on social welfare and perfect efficiency of individual welfare.

**Non-interdependencies between the two** – Apart from this relationship, there are various economical problems, which are not related to an individual, and many problems do not relate to whole economical structure. For example, there is the difference between a person's income and his expenditure, but for a whole economical state, the income and expenditure are always equal. An individual can invest without savings but savings and investment should always be equal to an economy. When there is full employment in an economy then a firm can increase its production attracting the of other firms. But the whole industry could not increase resources of that type. The export of a country can be more than import or vice versa but for the whole world the export import should be equal.

**Proper integration of the two approaches** – Actually, there is not a true line between micro and macroeconomics. Both should come under a simple law of economics. There is a simple theory, that both should come under a general theory of the economy. This principle should be the prices, production, income, individuals, individual firms and industries to explain the behaviour of groups and individual variables. In macroeconomics and microeconomics really no line can be drawn correctly. A general theory of the economy clearly will embrace both; personal behaviour, personal income, and prices will interpret and create groups with individual results add or averages macroeconomics is concerned. There is a general principle, but the scope has left fewer things from it. Thus, the main thing is to mix the both economics. **Prof. Ackley** has given suggestion that the microeconomics should give the building blocks for macroeconomics. But to understand the macroeconomics, microeconomics is also helpful. For example, if we search some economical theories for stable microeconomics which should not match with macroeconomical theory or not related to any behaviour which is avoided by macroeconomics then microeconomics should allow to update our knowledge and behaviour but to ride on this way, we do not need to know the technical difficulties which states that "the macroeconomical theory of pricing and income depends on microeconomical theories."

## 1.5 Summary

- There should be no line in micro and macroeconomics. Both should come under a simple line of economics. There should be a law which can describe the pricing, production, income, individual, individual firm and company. In fact, we cannot draw a line between micro and macroeconomics. A simple theory of economy can relate with both; will describe an individual behaviour, income and pricing and this average will add or create a group which will create macroeconomics. However, this type of theory we have but the wholeness affects this to use widely. To reach the true result, we can find that the problem of micro can be defined by microeconomics and vice versa.

## 1.6 Keywords

- **Microeconomics:** The study of smallest part of an economy
- **Macroeconomics:** The study of a wide range of economy

## 1.7 Review Questions

1. What do you mean by microeconomics?
2. What do you mean by macroeconomics?
3. Give differences between micro and macroeconomics.
4. Describe the dependencies of micro over macroeconomics.

Notes

**Answers: Self Assessment**

- |            |             |           |           |
|------------|-------------|-----------|-----------|
| 1. Analyse | 2. Taxation | 3. Micros | 4. (a)    |
| 5. (b)     | 6. (c)      | 7. (b)    | 8. (a)    |
| 9. True    | 10. False   | 11. True  | 12. False |

**1.8 Further Readings**



*Books*

1. **Microeconomics**—*Frank Kowell, Oxford University Press, 2007.*
2. **Microeconomics**—*Robert S. Pindyck, Daniel L. Rubinfeld and Prem L. Mehta, Pearson Education, 2009, PBK, 7th Edition.*
3. **Microeconomics**—*David Basenco and Ronald Brutigame, Wiley India, 2011, PBK, 4th Edition.*



## Unit-2: The Concept of Equilibrium

### CONTENTS

Objectives

Introduction

- 2.1 Meaning
- 2.2 Static Equilibrium
- 2.3 Dynamic Equilibrium
- 2.4 Stable Vs Unstable Equilibrium
- 2.5 Neutral Equilibrium
- 2.6 Partial Equilibrium
- 2.7 General Equilibrium
- 2.8 Summary
- 2.9 Keywords
- 2.10 Review Questions
- 2.11 Further Readings

### Objectives

After studying this unit, the students will be able to:

- Know the Logic of Equilibrium.
- Understand the Logic of Static Equilibrium.
- Know the Logic of Neutral Equilibrium.
- Understand the Logic of General Equilibrium.

### Introduction

Equilibrium state presents a characteristic of equilibrium theory and that equilibrium is a state of stability. Here motion plays a role to balance different powers. Once this condition is met, then there is no tendency of going away from it.

Notes

**2.1 Meaning**

Equilibrium is derived from the Latin word 'aequilibrium' which means equal weight. In economics its application has been taken from Physics. In Physics, it means equal. This is the state of weight where opposite power or tendencies deactivate each other. **Prof. Stigler** states the theory in these words, "Equilibrium is the state where motion doesn't act. We say it because this state does not fix automatically but differentiate the power." Equilibrium means the state of rest, which shows the lack of change. In the words of **Prof. J. K. Mehta**, "In Economics, equilibrium states the absence of changes in motion." This is the state where all participants in market agree on each other's opinion and nobody needs to change or exchange his opinion. In other words, this is the market condition where all its participants have full faith on each other. In the words of **Sketovosky**, "A market or an economy, or power and the group of firms feel secure when nobody wants to change his behaviour. So to balance a group it is necessary to balance all individuals on its group and they balance each other". Let's assume that everyday a requisite amount of fish comes in a market and fulfill buyer demand. To do this constantly, it is necessary to fix the price of fish. This equilibrium state remains until the demand and buy are equal. The amount on which fish sells and buys is called **Equilibrium price** and the quantity of fish that sells and buys on that price is called **Equilibrium quantity**. Neither seller nor buyer feels to change this equilibrium price. For example, in Fig. 2.1, supply line 'S' and demand line 'D' cut each other at point E, which elaborates the point of balance and OP and OQ, demonstrate the equilibrium price.

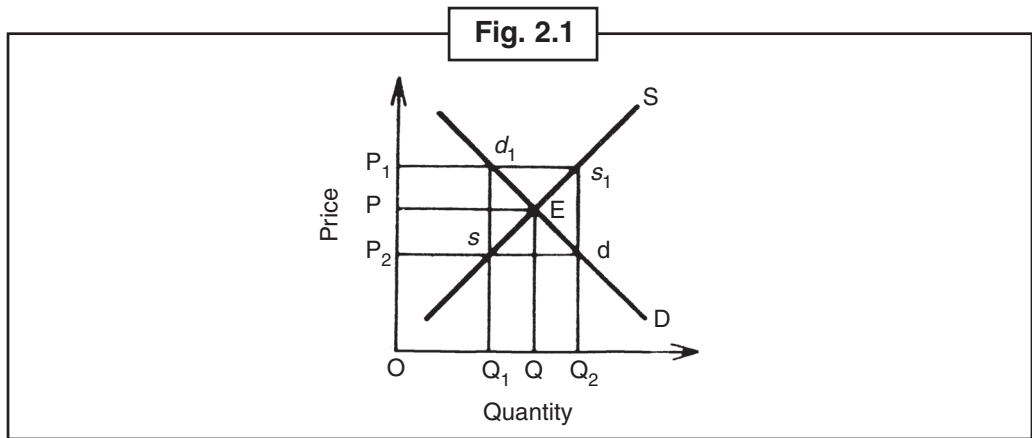

If the price falls anyhow and comes to below its equilibrium price  $OP_2$  then the demand will increase and supply will decrease means  $P_2d > P_2^S$  power will be effective and drive the price to its equilibrium state E. Thus, supply will increase by increasing price from equilibrium level to  $OP_1$  level and demand would decrease means  $P_1^S > P_1d_1$  and price will come again on E.

**Self Assessment**

**Fill in the blanks:**

1. Equilibrium is the state in which motion does not have .....
2. After a period when equilibrium state demolished then it is called .....
3. A full load of boat remains .....

## 2.2 Static Equilibrium

Equilibrium state, defined above, elaborates another goodness of equilibrium theory that is stability. The motion has the power to make constant each other's differentiate power. Noone needs to move when reached in this condition. According to **Prof. Mehta**, "Static equilibrium is the equilibrium which makes constant itself even after a period of time." Every person, firm or company wants to take this pleasure and nobody wants to leave this if gets this state. A **consumer** is in equilibrium state when he gets maximum with his fixed amount on various things and services. The consumer feels displeasure if he found himself in a condition where he needs to re-divide his total expenditure to buy things. A **firm** is in equilibrium state when its profit touches its maximum level and it does not want to increase its production. Profit will decrease if this condition is lost anyhow. Therefore, an **industry** is in equilibrium state when it doesn't want to change its production quantity or quality. In this state, present firms want to leave the business and new firms do not want to enter in the market. In other words, any industry relaxed in equilibrium state when all firms get normal profit. An **employee factor** is in equilibrium state when he gets his maximum price and there is maximum demand. He neither decreases or increases his service and doesn't want to go for another job. His earning will affect if he will do so. Static equilibrium is defined by **Prof. Bolding** in his words, "A ball rolling at a constant speed or better if we take example of a forest where tree grows or get destroyed nothing made changes in the structure of a forest. Here we can see equilibrium in a physical mode." Static equilibrium is what depends upon fixed price, demand, quantity and population.



Notes Static equilibrium is the equilibrium, which remains after a period of time.

## 2.3 Dynamic Equilibrium

In dynamic equilibrium prices, quantities, income, demand, machinery and population always change. So in a fixed time, there is non-equilibrium state in respect of equilibrium condition. If there is opposition in the participants of market then it affects badly to the equilibrium state. If any participant is in non-equilibrium mode then he can affect other participants too. These start a chain of reaction among all the participants which equalize the thought of all the participants and developed a new equilibrium state. As **Prof. Mehta** says, "After a fixed time, when equilibrium mode is over, then it is called Dynamic Equilibrium."

We go forward with our example. Suppose that if some people buy fish then it will increase the demand. It will affect all the participants of the market. Sellers will increase the price and this will affect old buyers. Market will be non-stable till the supply will not reach the level of demand. From here the opposite power will get a new mode of equilibrium. Figure 2.2 shows this whole process with the help of **Cobweb Theorem**.  $a$  is the primary equilibrium state from where problem starts. When demand increased by  $D_1$  then price go on  $OP_1 (= qb)$  but when the demand of fish increased in long period then the price comes down to point  $g$ , where  $Oq_3$  demand and supply occurs in a new equilibrium price  $OP_3 (q_3g)$ . This clarifies the **Dynamic Equilibrium**.

Notes

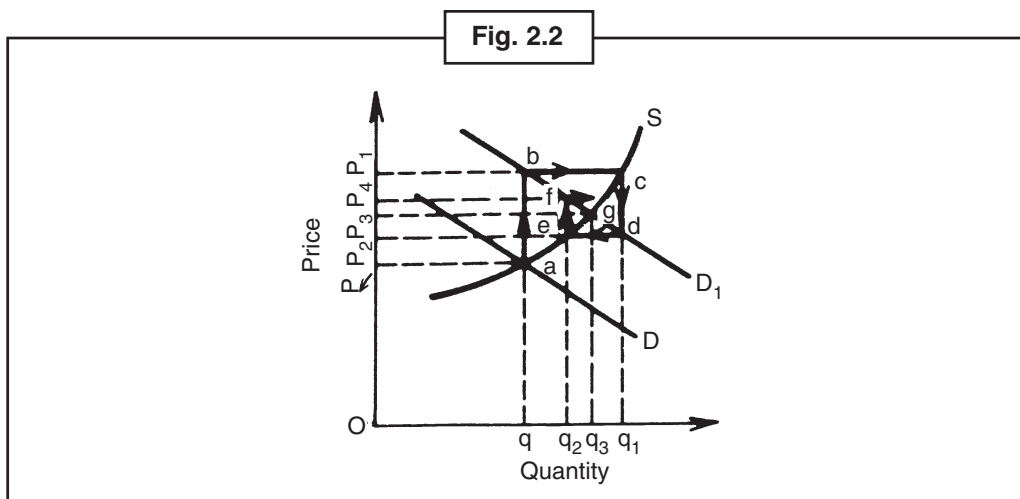

But the question is when the new equilibrium state will come and how? The supply of fish can't be increased in a day. It will take time for producer to think and produce the thing and come with more quantity. This is called Lagged Adjustment, which can understand, by Cobweb Theorem. In Fig. 2.2 when demand increases from D to D<sub>1</sub> then price increases by qb (= OP<sub>1</sub>) and hopes to remain in this state for a time being. So this price attracts the producers to increase qq<sub>1</sub> amount in supply and come the total supply to Oq<sub>1</sub>. But this equilibrium quantity is greater than Oq<sub>3</sub>, which market needs. Thus the price would again decrease by dq<sub>1</sub> (= OP<sub>2</sub>) and it will change the plan of producer, which decreases the supply on Oq<sub>2</sub>. Buy this quantity is less than equilibrium quantity Oq<sub>3</sub>, so the price would increase by OP<sub>4</sub> which boosts supply and takes it on Oq<sub>3</sub>. At last there would be an equilibrium stage on point g where S and D<sub>1</sub> curves cross to each other and prices-quantity combination is now OP<sub>3</sub> – Oq<sub>3</sub>. It is called **Dynamic Equilibrium with Lagged Adjustment**.

### 2.4 Stable Vs Unstable Equilibrium

Various equilibrium states shown above are related to **Stable equilibrium**. If any problem occurs in equilibrium then it changes itself and establishes the old stage as shown in Fig. 2.1. As per **Marshall**, "When the price of demand is equal to price of supply then there is neither decrease nor increase of the new production quantity and it looks stable. This equilibrium is stable means if we made any changes in pricing then it will try to go at its minimum level." **Pigou** said that a boat having heavy keel is always stable. **Sumpiter** has given another example with a bowl and a ball. A ball in a bowl is always stable because if we move this then it always comes in its original stage.

On the other hand, the equilibrium becomes unstable when those powers become active which take this equilibrium state away from its normal condition and the equilibrium state never attains stability. In **Pigou's** words, "If there is little power changes the original state, then it is called unstable equilibrium." As per **Marshall**, "An egg is stable horizontally and if there are any changes then it will drop and lay vertically on floor." If we reverse the bowl and put the ball on it, then ball will become unstable and drop to the floor and never comes in its original place

The concept of equilibrium and non-equilibrium is related to equilibrium which is described in further units.

### Self Assessment

**Multiple choice questions:**

4. .... equilibrium is based on fixed data.  
 (a) Marginal            (b) Micro            (c) Macro            (d) Group

5. The marginal analysis has ..... types of economical problem.
  - (a) four
  - (b) two
  - (c) one
  - (d) three
6. Every firm of industry sells its things on ..... price.
  - (a) initial
  - (b) lateral
  - (c) current
  - (d) marginal
7. Marginal analysis has its own .....
  - (a) habits
  - (b) laws
  - (c) region
  - (d) boundary
8. The measurement of result is .....
  - (a) unstable
  - (b) stable
  - (c) small
  - (d) large

### 2.5 Neutral Equilibrium

One more equilibrium which is generally described, is Neutral equilibrium. When there is any change in initial stage, then the power of changes brings so many changes where it stays in a stable stage. The ball of a billiard hits then after moving fast the ball gets a new stable stage. As per **Prof. Pigou**, "A horizontally laid egg is a better example of neutral equilibrium. Stable equilibrium is shown in Fig. 2.3 and dynamic is shown in Fig. 2.4. In Fig. 2.3, E is at initial stable stage where DQ supply and demand meets on OP pricing. If price increases by  $OP_1$ , then a new constant stage develops as  $E_1$ , but the supply and demand remain same as OQ. Thus pricing border  $pp_1$  shows neutral equilibrium.

If market is dynamic then this increase of demand will increase the price from  $OP_1 (= QB)$  which boosts up the production quantity like Fig. 2.4. But demand price  $Q_1d$  is less than supply price, so the producer will try to increase supply to OQ. But on it, the demand is more than supply, so price will again increase by  $Qb (= OP_1)$ . Thus the price and quantity will move around the point e.

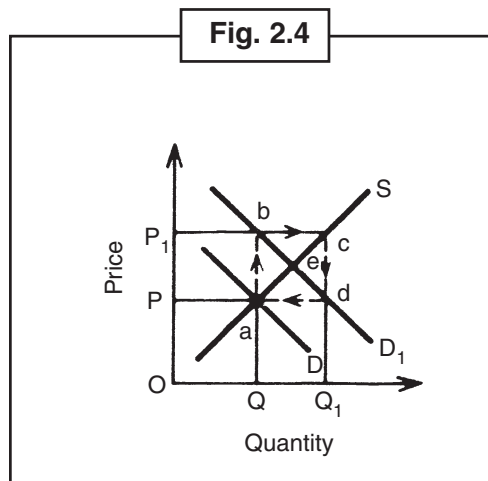
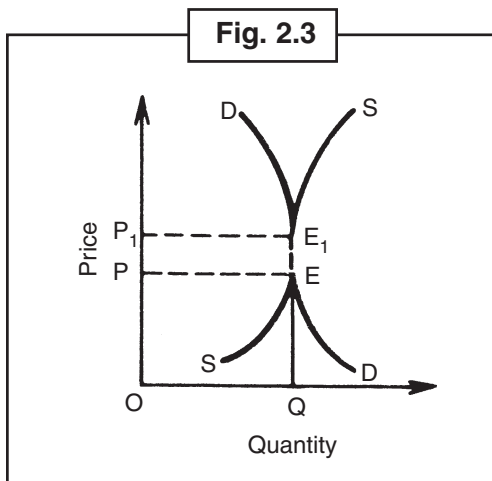

Here we can see that between stable, unstable and neutral equilibrium, only stable is interesting for economists which used to analyze in complex economical problems. Unstable and stable equilibrium is more for theoretical interest.



*Did u know?* In economics, equilibrium describes the absence of changes in motion.

## 2.6 Partial Equilibrium

Partial or Special equilibrium analysis which is also called Micro analysis describes the equilibrium of a person, firm or industry or a group of industry. This is a market process which fixes the price of products as well as resources' price and where economists analyse only on one or two points rather than all. In the words of **Stigler**, "The partial equilibrium is based on fixed data. One unique example is an analysis of a product pricing while all other product prices remain stable." The economics of Marshall belong maximum to the study of partial equilibrium analysis.

The partial analysis relates to two kinds of problems. **One**, which relates to unique behaviour of a person, firm or industrial economy. For example, this analysis limits itself to a product's market where we think about the price of product, production technique and the quantity of factors to produce the product. While all other factors are stable which affect pricing. **Second**, it only deals in the first order of result of that economical product it analyses. It does not define the effects of all the products' pricing and the effects of this pricing on the unique product pricing which it is studying.

We will study the equilibrium state of an individual, firm or industry in brief.

A consumer is in equilibrium state when he spends his income on various services and products that he gets maximum satisfaction. The conditions are (1) the marginal consumption of every product is based

on its price, means  $\frac{MU_A}{P_A} = \frac{MU_B}{P_B} = \frac{MU_N}{P_N}$ ; and (2) consumer should expend his all income to buy products, means  $Y = P_A Q_A + P_B Q_B + \dots + P_N Q_N$ . It supposes that his interest, use, income and the price of the products he wants to buy is already given and stable.

A **firm** is in equilibrium state when it does not want to change in its production. Its marginal revenue and marginal cost equals in short time and in long time, it qualifies for the full equilibrium terms means  $MC = MR = LAC$  on lowest point. Thus it gets normal profit and does not want to leave the industry. The production technique and the price of product and factors are given in analyzing the firm.

An industry is in **equilibrium** stage when every firm gets normal profit and neither any firm wants to leave nor any firm wants to join this industry. There is always a fixed price of a product in market by which consumer wants to buy, which is equal to the same amount produced the similar product in different firms. Every firm or industry sells their product on current market price and fixes those levels of production where its marginal cost and marginal revenue would be equal. They can decrease its production in short run but in long run, it is necessary that price is equal to its minimum average cost of production.

A factor of production (Land, Labour, Capital or Organization) is in equilibrium state when it works in his maximum paid work that his income is maximum. This is the condition when its price is equal to marginal revenue product. On that price, he does not want to change or do more or less to its service. Thus, there is only one price for resource which is distributed in all markets. Now, an owner of a resource is ready to sell his services but it should be equal to that is quantity which industrialist wants.

### Assumptions

The partial equilibrium analysis is based on the given pricing of the product. The interest, income, habits and demand are stable. For firms, the production technique and the price of other related products are stable. The industry gets the raw material on the stable price. If any change occurs like the interest of consumer or the production techniques then this stable law would change and the equilibrium stage comes on a new point. The analysis of market for a product assumes that the price of raw material as well as the quantity and price of their products are stable. Then the production technique between place and industries is fully movable. In a short term, a product can get lower profit but in a long term, this should be equal to its production value for all places.

The analysis of above is related to full competition of market and can be used in monopoly, monopolistic competition, oligopoly and one-rating market.

## Its Merits

The merits of partial equilibrium analysis are as follows –

**First**, it helps to analyze the price of a product or service. Thus, we can understand the changes of behaviour of a person, firm or industry.

**Second**, this is helpful to give result of behaviour and plan of economical market and can analyze the result of obstruction of state in the market. For example, we can check the production tax, production profit, etc. in cloth industry.

**Third**, this is a necessary resource to solve the real problems with centralize the problems by making small section; it helps to analyze and understand the problems easily.

**Last**, to understand the general working of economical structure where all parts depend on each other is the base of partial equilibrium analysis. It is impossible to understand and define the general equilibrium analysis.

## Limitations

But there are some limitations of partial equilibrium analysis. It only covers a unique boundary even it is a person, firm or industry. If we leave the unreal recognition which separates unique market from rest of the economy, then the partial equilibrium analysis ends. One economical problem of the market activates the unstability and this change affects first, second and third types of changes in economy. The partial equilibrium analysis is not capable to study the all parts of economy and their relation with each other parts. General equilibrium analysis is important to understand the relations of economical process.

## 2.7 General Equilibrium

General equilibrium is the study of economical relations and its dependencies which gives understanding of economical process. It conjugates the reasons and results of all the prices, quantities of products and the changes in services. An economy is stable when all consumers, all firms, all industries and all services are in equilibrium and product and services relates to **each other by price**. As **Stinger** said, "The theory of General Equilibrium is the theory of correlation of all the aspect of an economy."

General equilibrium happens when all the prices are stable; all consumers buy product with their maximum satisfaction; all firms of an industry are stable in terms of price and production; and in this stable pricing the demand and supply is equal. As per **Prof. Leftwich**, "For a whole economy, the general equilibrium is based on the partial equilibrium of all the economical processes."

## Its Assumption

The general equilibrium is based on these recognitions:

1. There is the competition in product market and factor market.
2. The likes and interests of a consumer are given and stable.
3. The income of consumer is given and stable.
4. The factors of production are moving in various industries and places.
5. The measurement of result is stable.
6. Every firm runs on equal production cost.
7. All processes are equal for a production unit.



- Notes**
8. There is no change in production technique.
  9. The labour and other resources are fully working.

### Working of the General Equilibrium System

As per above recognition, the economy is in equilibrium stage when every product and service meets the demand. It means there is uniformity in the decision of the all participants of the market. The decision of consumer to buy every product should equal to the production and selling of that product. Thus, the decisions to sell every service should equal to their labours. When sellers' thinking is equal to the buyers decision then General Equilibrium happens.

In an economy, if the likes and the interest are given for the consumers, the quantity of every product does not depend on its price but also depends on other product pricing. Thus every consumer gets full satisfaction against all the products. For him, every product is equally valuable on its price.



**Task** Give your opinion in regards to General Equilibrium.

In this analysis, it is assumed that every consumer spends his whole income in products, so his expenditure is equal to his income and in respect to his income, it depends that how he expends. On the other hand, the consumer gets income by selling his own products. Thus, the demand of various products depends on their pricing as well as their service.

Now we take supply part. If we have the production status, the shape of market and the ambition of firm, then the cost of the product depends on its production cost. If we assume that the measurement of different products of different production firms are stable then the producer will produce the product on its minimum average making cost. The product and market relation is figured out in Fig. 2.5. Market is in stable stage on pointer E where the demand and supply lines intersect each other. Here the OP is pricing of product on which  $OQ_M$  product quantity sells and buys in the market. In the equal cost, all firms produce and sell the quantity OQ then it is in the equilibrium state. Let's assume that there are 100 firms in the market and produce 60 types of products then the total product count will 6000 ( $100 \times 60$ ) units. This analysis can be used on other products in economy.

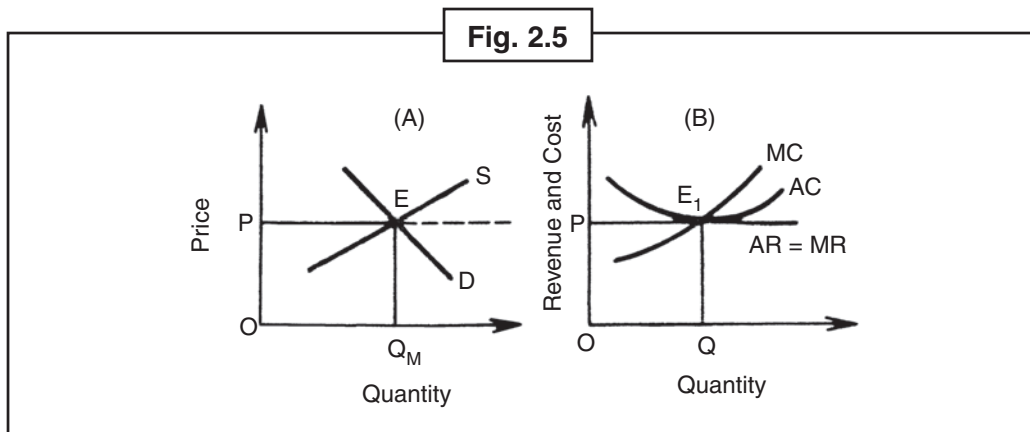

As the equilibrium of demand and supply, the factor-service and supply needs to be equal for General Equilibrium. The service demand comes from producers and supply comes from consumers. If the technique is given and the profit target has given, then the production cost of a product depends upon the production cost of various products produces by that producer. Since the economy has full employment so the market is stable for the factors; when the service for product is equal to the production factors of that product. The service-market equilibrium is displayed in the Fig. 2.6 (A) where the service cost  $OP$  and its quantity  $ON$  depends on pointer  $E$ , then its demand and supply curve cuts as  $D$  and  $S$ . The panel of diagram (B) shows that for an individual firm, the supply curve of this factor is liberal and it is equal to the marginal factor of cost ( $MFC$ ) of that factor. This firm will appoint the units to its given price  $OP$  where  $MFC = MRP$  and  $AFC = ARP$  is that equilibrium point  $E_1$  on which they put  $OM$  units of factor. If there are 10 equal cost firms and every units puts 100 units of factor, then the total market demand and supply would be 1000 units for this factor. This analysis can spread over all economies.

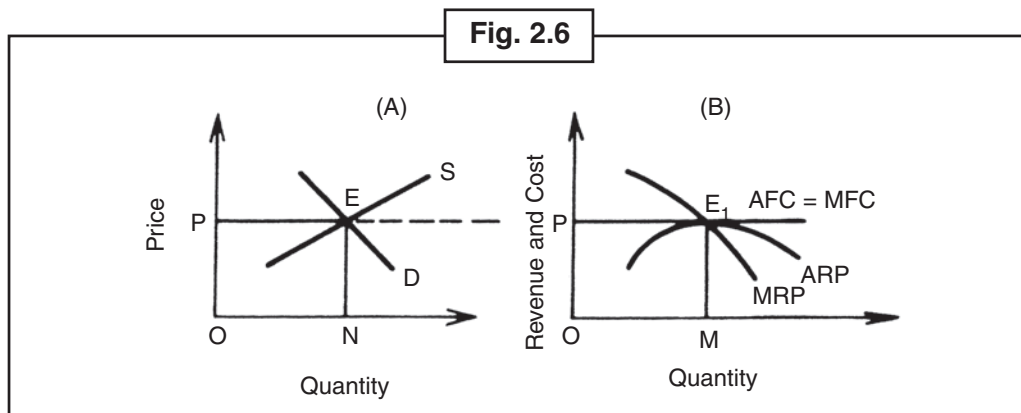

Thus, an economy is in general equilibrium when demand meets the range of supply and the service is covered as per demand and all things are in equal state. For this type of general equilibrium, there are two conditions (1) every customer gets maximum satisfaction and every producer gets maximum benefit; (2) all products and services sell in all the markets; it means the demand meets the supply with the positive and effective pricing. To describe this, we assume a fictional economy with two sectors – household and business. Economic activity takes the flow and flow of rupee on these two sectors. These two flows are called actual and economical flow respectively which are shown in Fig. 2.7 where product market is in below field and factor market is in above field. In the product market, a consumer buys product and services from the producer, where in the factor market; the customer gets income against his service. Thus, all the products or services are bought by the consumers and give money to the producers. Producers give money or similar things like money for their services and interest on their money etc. Thus as figured out by arrow in the outer part of the diagram, the money revolves from consumer to producer and vice versa. The products come from business market to household market and go to household. Also as seen in the inner part of the diagram, the service offers from the household market to business market. These flows are attached with product price and service price. When consumer gives services and gets money against it and like this producer gets profit and sells his products, then the economy is in General Equilibrium.

Notes

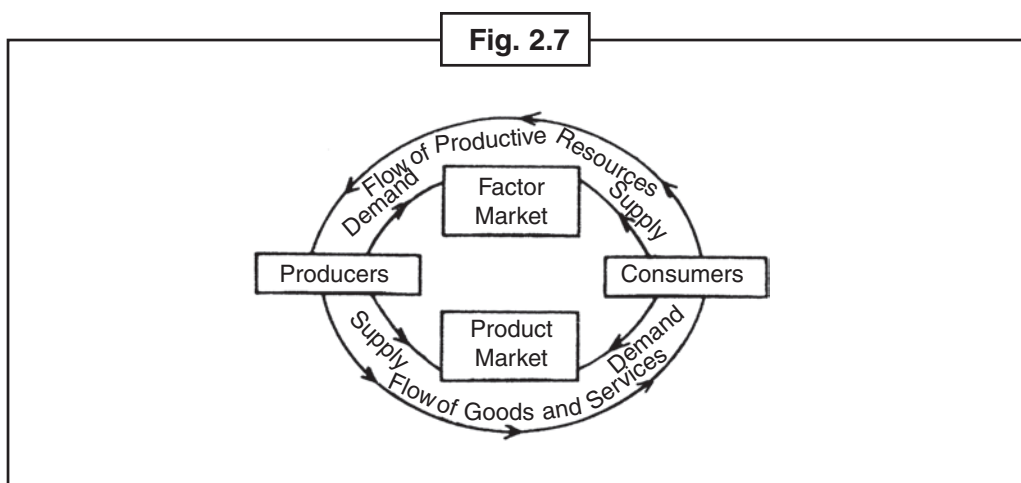

### Self Assessment

State whether the following statements are True/False:

9. The assumption of stable and unstable equilibrium depends upon constant equilibrium.
10. Static equilibrium is the equilibrium which maintains itself before a given time of frame.
11. In Economics, equilibrium states the changes in motion.
12. The economics of Marshall relate to the study of maximum partial equilibrium analysis.

### Its Limitations

There are so many limitations in economical general equilibrium:

**First**, it depends on much unreal recognition which is opposite to the challenges in real world. Full contest, which is the base of this equilibrium, is false.

**Second**, this analysis is static. In this analysis, all consumers and producers, without any delay of time, consume and produce products in a daily basis. Their interest and likes are remaining same and their economical decision fully depend on each other. In fact, this never happens. Consumer and producer never think like this and never work in a single type. Likes and interests always change. The measurement of interests are never same and two interests are never same to owe. Thus the cost of production differs for every producer. Because the interest always changes, so the motion stops at general equilibrium and it always a desire to get it.

**Lastly Prof. Stinger** votes that, "General equilibrium is a false concept. None economical analysis is normal which thinks on equilibrium studies rather than unique equilibrium studies, but it never fulfils. Apart from this, if the analysis is general, the outcome will be more general rather than definite."

### Uses of General Equilibrium Analysis

There are so many benefits of General Equilibrium Analysis:

1. **A picture of economy's equilibrium:** It produces the picture of an economical equilibrium of private company, where the consumer gets maximum satisfaction and the producer gets maximum benefits. There is no loss of services. Everyone gets full employment. There is maximum economical

expertise and hence the social welfare is also maximum. Thus, it helps to understand the basics of any economical structure.

2. **To understand the working of economic system:** This theory is different from other theories and if we remove some unreal recognition, then can understand a picture of an economical process. We can understand that economy is working fine or not. By this analysis, we can study the non-equilibrium problems and their resolving.
3. **To understand the complex problems of the market:** Again, general equilibrium analysis helps to tell the result of any autonomous economical incident. Let's assume, the demand of product A has increased and hence the price can increase. Thus, the demand of parallel products becomes lesser and this makes the product A costlier. By this, the demand of A can become less. If producer increases the price of A then it more affects the demand of A. Thus, this general equilibrium analysis helps to understand the complex market behaviour.
4. **To understand the working of pricing process:** The general equilibrium analysis helps to understand the process of pricing in economy. The primary price always changes, so can take decision against a whole economy - which product should make; how product should make; and who will be the consumer of this product. Personal consumer and producer take this decision because the product which they buy or make has a value and this reacts if the demand and supply changed. Thus the general equilibrium analysis helps to conjugate many personal decisions which affects pricing.
5. **To understand the input output analysis:** The general equilibrium helps to base the input output analysis which is developed by **Leontiff**. In this analysis, which is the base of general equilibrium analysis, can help to study the behaviour of input output of household and industrial economy. This analysis is used more to make plans of backward countries and regions.

## 2.8 Summary

- The general equilibrium is a vast study of economical changes and its relation as well as dependencies and it helps to understand the process of whole economy. This conjugates the reason and results of price, quantity of products and changes in services in compare to whole economy. An economy can only be in general equilibrium state when all the consumers, firms and industries are in equilibrium state and the product and factor relates to each other. As **Stinger** said, "The theory of general equilibrium co-relates each other with all economical process."
- When all prices are same, then it is in general equilibrium; all consumers get maximum satisfaction with their earnings; all firms or all industries get equal in profits and production; and in the equal price, the demand and supply should equal. In the words of **Prof. Leftwich**, "The general equilibrium happens for an economy when all the industries get its partial equilibrium state."

## 2.9 Keywords

- **Equilibrium:** Equal on weight
- **Partial equilibrium:** Limited equilibrium
- **Neutral Equilibrium:** Fixed economy

Notes

### 2.10 Review Questions

1. Describe the Dynamic Equilibrium. Prove that from time to time, we can get equilibrium in our real life.
2. Describe the equilibrium and with the help of **Cobweb Theorem**, prove that we can get equilibrium in some given incidents.
3. Describe the differences between partial and general analysis and give details of general equilibrium.
4. Describe the differences between dynamic and static equilibrium. Give diagram and illustration to prove your theory.
5. "The equilibrium concept is the key in today's economical analyses." Describe it.

### **Answers: Self Assessment**

- |           |            |                |
|-----------|------------|----------------|
| 1. Pure   | 2. Dynamic | 3. Equilibrium |
| 4. (a)    | 5. (b)     | 6. (c)         |
| 7. (d)    | 8. (b)     | 9. True        |
| 10. False | 11. False  | 12. True       |

### 2.11 Further Readings



*Books*

1. **Microeconomics** – Shipra Mukhopadhyay, Annie books, 2011.
2. **Microeconomics: An advance treatise** – S.P.S Chauhan, PHI Learning.
3. **Microeconomics: Behaviour, Institutions and Evolutions** – Sampool Bowels, Oxford University Press, 2004.

## Unit-3: Consumer Theory-Cardinal Utility Analysis

### CONTENTS

Objectives

Introduction

- 3.1 Cardinal Utility Analysis
- 3.2 Total and Marginal Utility
- 3.3 Difference and Relation between Total Utility and Marginal Utility
- 3.4 Significance of the Difference between Total Utility and Marginal Utility
- 3.5 Law of Diminishing Marginal Utility
- 3.6 Basic Assumptions
- 3.7 Explanation
- 3.8 Derivation of Consumer's Demand Curve Through the Law of Diminishing Marginal Utility
- 3.9 Law of Equi-Marginal Utility or Utility Analysis and Consumer's Equilibrium
- 3.10 Modern Statement of the Law
- 3.11 Importance of the Law
- 3.12 Criticisms of the Law
- 3.13 Consumer's Surplus: An Illustrative Description
- 3.14 Summary
- 3.15 Keywords
- 3.16 Review Questions
- 3.17 Further Readings

Notes

## Objectives

After studying this unit, students will be able to:

- Know the Law of Diminishing Marginal Utility.
- Understand the Law of Equi-Marginal Utility.
- Know the Importance of the Law.
- Know the Modern Statement of the Law.

## Introduction

To begin, we need a description of the goods and services that a consumer may consume and his monthly income. How a rational consumer would make consumption decisions? In economics we say **commodity** to goods and services. If his income meets his desire and brings satisfaction in his life. To understand this, in economics three theories have been established:

(1) **Cardinal Utility Analysis** (2) **Ordinal Utility Analysis or Indifference Curve Analysis** (3) **Revealed Preference Analysis**.

### **What is Utility?**

*Utility refers to the total satisfaction received from consuming a product or service. In clear terms want-satisfying capacity of a product is called Utility. Any goods or service may have good or bad utility. For example, a cigarette smoker feels satisfaction with every puff; no doubt it is dangerous to health.*

## 3.1 Cardinal Utility Analysis

In the 19th century, the neo-classical economists like **Duipit, Gossen, Walras, Menger** and **Jevons** put forward cardinal utility analysis criticizing the classical thought propagated by **Adam Smith, Ricardo** and others. While in 20th Century, **Marshall** and **Pigou** further elaborated Cardinal Utility Analysis. According to this analysis utility can be measured in cardinal numbers such as 1, 2, 3, 4 etc. Cardinal numbers either can be added or subtracted. **Fisher** has used this term "Util" as measure of utility. Thus in terms of cardinal utility analysis it can be said that one gets from a cup of tea 10 units, 5 units from a cup of coffee.

### **Cardinal Utility and Ordinal utility theory**

*According to Cardinal utility theory, utility can be measured in cardinal numbers such as 1,2,3,4 etc and these numbers either can be added or subtracted. While Ordinal utility theory holds that the utility of a particular goods or service cannot be measured using a numerical scale bearing economic meaning in and of itself. Ordinal utility implies merely quality and ranking of the level of satisfaction experienced.*

## 3.2 Total and Marginal Utility

According to the Utility measurement there may be two concepts: (1) Total Utility and (2) Marginal Utility.



## 1. Total Utility

It is the aggregation of utilities obtained from the consumption of two different units of a commodity. In other words, total utility is the measurement of satisfaction derived from consuming quantity of some goods. It is the function of the quantity of a commodity consumed and is expressed as

$$TU_x = f(Q_x)$$

[The total value of this is read as  $\sum (TU_x)$ , X- commodity quantity ( $Q_x$ ) is a function of ( $f$ ).]

In the words of Leftwich, "Total Utility refers to the entire amount of satisfaction obtained from consuming various quantities of a commodity." Assume that you eat 8 Rasagullas at a sitting. The aggregation of the utilities obtained from the 8 Rasagullas will be called Total Utility.

## 2. Marginal Utility

The concept of Marginal utility was put forward by the eminent economist named Jevons. The other name for Marginal utility is **additional utility**. The marginal utility is the gain (or loss) from an increase (or decrease) in the consumption of that goods or service. Assuming that by the consumption of the 1 chapatti you get 15 units of utility while consuming the 2nd one your total units goes upto 25. This means that the consumption of the 2nd chapatti added only 10 units to the total utility. Thus the marginal utility of the second chapatti is only 10 units.

According to Lipsey, "Marginal utility is the addition made to the total utility by consuming one more unit of commodity."

$$MU_{nth} = TU_n - TU_{n-1} \text{ Or } MU = \frac{\Delta TU}{\Delta Q}$$

(Here  $MU_{nth}$  = nth marginal utility of unit;  $TU_n$  = n the total value of units;  $TU_{n-1}$  = n - 1 the total utility of the unit  $\Delta TU$  = total utility;  $\Delta Q$  = change in the amount of object)

Marginal Utility can be (1) **positive** (2) **Zero** and (3) **Negative**.

- (i) **Positive Marginal Utility:** Positive marginal utility is the change in total utility by the consumption of an additional unit of commodity. Suppose to satisfy your hunger you eat chappatis, from the first one you get 8 units and while from the second one you get 6 units. Altogether you have got  $8 + 6 = 14$  units. Thus, by taking the additional units of chappatis, total utility goes on increasing. The marginal utility which you derived from the second chappatis is known as positive marginal utility.
- (ii) **Zero marginal utility:** When the consumption of extra units of items has no change on the total utility, it means that the marginal utility of the additional unit is Zero. **At this level the consumption utility will be maximum.** So as far as the satisfaction of the consumer is concerned, **it will be his saturated point.** Suppose 4 chapattis of bread yield total utility of 20 units and the consumption of 5th chapatti does not make any change in the total utility and the utility remains 20, that means the marginal utility of the 5th one is Zero.
- (iii) **Negative marginal utility:** When the consumption of every extra unit decreases the utility derived from it, then it is known as negative marginal utility. After receiving the saturation point, after taking 5 chapattis, if the consumer is forced to take the number 6 chapatti, he may suffer from indigestion. Therefore, the total utility of the 6 chapattis may come down to 18 units, which signifies that the marginal utility is negative 2 i.e  $(18 - 20) = -2$ . Hence  $-2$  is the negative marginal utility.

Notes

**How Total Utility is different from Marginal Utility?**

*Total Utility is the aggregation of utilities obtained from the consumption of two different units of a commodity. While the marginal utility is the gain from an increase in the consumption of that goods or service.*

$$TU = \Sigma MU$$

$$MU_{nth} = TU_n - TU_{n-1}$$



*Notes* Marginal utility is the change in total utility by the consumption of an additional unit of commodity.

**3.3 Difference and Relation between Total Utility and Marginal Utility**

A neo-classical economist, **Jevons** was the first person to highlight the relationship between Total Utility and Marginal Utility and its differences also. Difference and Relation between Total Utility and Marginal Utility may be explained with the help of the below Table 3.1 and Fig. 3.1.

<b>Table 1: Relation between Total Utility and Marginal Utility</b>			
<i>Quantity</i>	<i>Total Utility</i>	<i>Marginal Utility</i>	<i>Description</i>
1	8	8 - 0 = 8	Positive marginal Utility Total Utility is increasing
2	14	14 - 8 = 6	
3	18	18 - 14 = 4	
4	20	20 - 18 = 2	
5	20	20 - 20 = 0	Zero marginal Utility Total Utility is Maximum
6	18	18 - 20 = -2	Negative Marginal Utility Total Utility is decreasing

From the Table 1 we can see that Total utility is the sum total of the marginal utilities corresponding to various units of a commodity consumed.

(i)  $TU = \Sigma MU$

(Here TU = Total Utility;  $\Sigma$  = Pulse it is Summation; MU = Marginal Utility Or Total Utility = Addition of marginal Utilities)

$$\begin{aligned}
 TU_6 &= MU_{(1st)} + MU_{(2nd)} + MU_{(3rd)} + MU_{(4th)} + MU_{(5th)} + MU_{(6th)} \\
 &= 8 + 6 + 4 + 2 + 0 + (-2) = 18
 \end{aligned}$$

On the flip side, Marginal Utility refers to the change in the total utility corresponding to a unit change in the consumption of a commodity.

(ii)  $MU = \frac{\Delta TU}{\Delta Q}$  or  $MU_{nth} = TU_n - TU_{n-1}$

(Here  $MU_{nth}$  = nth Marginal Utility of the unit;  $TU_n$  = Total utility of all the n units consumed;  $TU_{n-1}$  = Total Utility of n-1 units)

$MU$  = Marginal Utility;  $\Delta TU$  = Change in total utility;  $\Delta Q$  = Change in the consumption of the commodity.

For Example:

$$MU \text{ of 4th Unit} = TU \text{ of 4th unit} - TU \text{ of 3rd unit} = 20 - 18 = 2$$

$$\text{Or } \frac{\Delta TU}{\Delta Q} = \frac{TU \text{ of 4th Unit} - TU \text{ of 3rd Unit}}{4 - 3} = \frac{20 - 18}{1} = \frac{2}{1} = 2$$

- (iii) Marginal Utility tends to diminish as more of the commodity is consumed. However, total utility increases with every additional unit of the commodity consumed till the point when the marginal utility becomes zero.
- (iv) Total utility remains positive while the marginal utility remains Negative or Zero.
- (v) Total utility becomes maximum while marginal utility is Zero.
- (vi) Marginal Utility determines the rate of change in total utility.

The relationship between Total Utility and Marginal Utility can be expressed diagrammatically Fig. 3.1. In part 'A' and 'B' of Fig. 3.1 units of the commodities are shown on OX-axis and utility on OY- axis. In Fig. 3.1 (A) curve TU represents Total Utility. It is moving upto point 'F', which indicates that the total utility has been rising upto the consumption of 4th unit. From the point F to G the total utility is constant, which indicates that the consumption of the 5th unit has not made any addition to the total utility. Both these points signify maximum height of total utility curve. Point 'G' represents the maximum total utility at the 5th unit which is the point of saturation. After point 'G' the TU curve moves downward thereby at the 6th unit Marginal utility becomes negative and total utility begins to fall.

Fig. 3.1

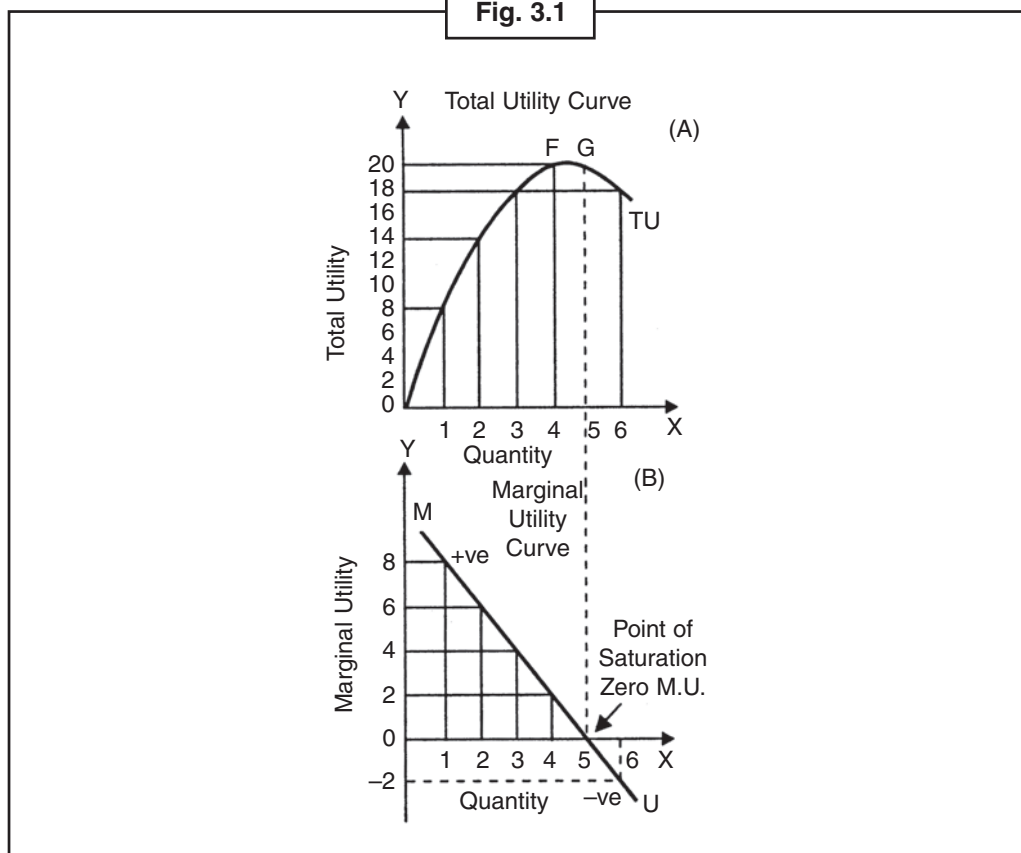

**Notes**

In Fig. 3.1(B) MU curve represents Marginal Utility. It moves downward from left to right, which signifies that marginal unit of successive units, goes on vanishing. Upto the fourth unit of the commodity, marginal utility goes on vanishing while Total utility goes on increasing. Hence it is proved that upto the fourth unit of the commodity marginal utility is positive. At the fifth unit where MU touches OX-axis, Marginal utility is Zero. In such a case the total utility is maximum. After the fifth unit the MU curve intersects OX-axis and moves downwards. This suggests that the sixth unit yields negative Marginal utility and in this situation the total utility begins to diminish.

**Self Assessment**

**Fill in the blanks:**

1. Utility refers to the total ..... received from consuming a goods or service.
2. Fisher has used the term ..... as measure of utility.
3. Marginal utility is also known as ..... utility.

**3.4 Significance of the Difference between Total Utility and Marginal Utility**

---

The difference between Total Utility and Marginal Utility has the following practical significance:

1. **Paradox of Value or the Diamond-Water Paradox:** Many economists have assumed that the price of a commodity was equal to its total utility. Thus the commodity, which gives more total utility should have more value and vice versa. But it is not so in actual life. One obtains more total utility from water than the diamonds, yet the price of water is much lesser than diamonds and this situation is known as Paradox of Value or the Diamond-Water Paradox. **Adam Smith** has developed the theory of the Diamond-Water Paradox as water is more important for the existence of life, yet it is cheaper. Diamond is only aesthetic, but is very expensive. The neo-classical economist **Jevons** has explained this paradox with the help of the difference between Total Utility and Marginal Utility. He criticized **Adam Smith** by saying that he has forgotten that water is cheaper as it is found in abundance, so its Total Utility soon reaches to the point of saturation. While the marginal utility soon reaches to Zero. Consequently, the price of water is almost Zero. While on the flip side the availability of diamond is very rare, so there total utility is far from the point of saturation. As a result the marginal utility of diamond remains high and positive. The high marginal utility corresponds with a relatively high demand price, so it is notoriously expensive.

*A consumer pays price for a commodity, is not equal to its total utility but is equal to its Marginal utility. When the consumption of commodity increases, the marginal utility decreases. So the consumer wants to pay less for every units of commodity as compared to its first unit of commodity.*

2. **Consumer's Surplus:** Sometimes a consumer is ready to pay much higher price for a commodity then its actual price. The difference between what consumers are willing to pay for goods or services relative to its market price is known a consumer surplus. The consumer is ready to pay the price which is equal to the total utility that he received from all of the commodities but in actual he pays the price equal to the marginal utility of the marginal unit of the commodity. **Here marginal unit is referred to the additional unit that the consumer is ready to buy. Apart from this each unit preceding the marginal unit (also known as intra marginal unit) would give the consumer more utility than the marginal utility.** The aggregation of marginal utilities of these units is known as Total utility. As the price is equal to marginal utility, the amount of the money paid by the consumer is equal to the marginal utility multiplied by number of the units bought. Of course, there will be a difference

between the total amount of consumers would be willing to pay to consume the quantity of goods transacted on the market and the amount actually have to pay for those goods. This difference is called Consumer Surplus. The concept of Consumer Surplus is based on the difference between Total Utility and Marginal Utility.

### 3.5 Law of Diminishing Marginal Utility

The Law of Diminishing Marginal Utility is the foundation stone of utility analysis. We experience this in our day to day life. If you are set to buy pen at any given time, then the number of pens with you goes on increasing while the marginal utility from each successive pen will go on decreasing. It is the reality of man's life which is referred in economics as **law of diminishing marginal utility states that other things being equal, the marginal utility of goods diminishes as more of it is consumed in a given time period.**

In the 19th century, few economists like **Bentham, Gossen, Menger, and Walrus** attributed this law. According to **Jevons** this law is based on **Weber-Fechner's** Psychological law. His Psychological law states that with increase in the quantity of the commodity the significance of the additional unit goes on diminishing. **Prof. Boulding** called it, "**Law of Eventually diminishing marginal utility**". It is also known as **Gossen's First law**.

1. **According to Marshall**, "The additional benefit which a person derives from a given stock of a thing diminishes with every increase in the stock that he already has."
2. **According to Samuelson**, "The law of diminishing marginal utility states that ceteris paribus as the amount of goods consumed increases, the marginal utility of that goods diminishes."

It is clear from the above definition that **at given time when we continue to consume additional units of a commodity, the marginal utility from each successive unit of that commodity, other things being equal, go on diminishing in relation to the proceeding unit. It is this diminishing tendency of the marginal utility, which has been sainted in law of diminishing marginal utility.**



*Did u know?* Total utility never reach the point of saturation.

### 3.6 Basic Assumptions

The three main assumptions of this law are the following:

1. Every unit of the commodity being used in the same quality and size, for example, a cup of tea or a glass of water.
2. There is a continuous consumption of the commodity.
3. Marginal utility of the every commodity is independent.

Notes

**3.7 Explanation**

This Law can be explained with the help of Table 2 and Fig. 3.2.

Table 2: Law of Diminishing Marginal Utility	
Ice Cream Consumed	Marginal Utility
First	4
Second	3
Third	2
Fourth	1
Fifth	0
Sixth	-1

The above table shows that first cup of ice cream yields 4 units of marginal utility. This will satisfy your want to some extent and the intensity of the want will come down. While the second cup of ice cream will yield less marginal than the first one, again third cup of ice cream will yield less marginal utility than second and this way fifth cup of ice cream will yield Zero marginal utility. If one is forced to take the sixth one then the marginal utility becomes negative and one may suffer from indigestion.

It is proved from the above table that if more and more units of ice cream are consumed then the MU from the each successive unit will diminish.

In Fig. 3.2. below, units of ice-cream are shown in OX axis while marginal utility is shown in OY axis. AB is the Marginal Utility curve. It slopes downward from left to right indicating that first cup of ice cream has yield 4 units, second cup of ice cream has yield 3 units, third cup of ice cream has yield 2 units, fourth cup of ice cream has yield 1 unit, fifth cup of ice cream has yield 0 unit. So AB touches OX-Axis at point 'C' which represents the fifth cup of ice cream while sixth cup of ice cream has given negative (-1) unit. Here AB curve goes below OX-Axis.

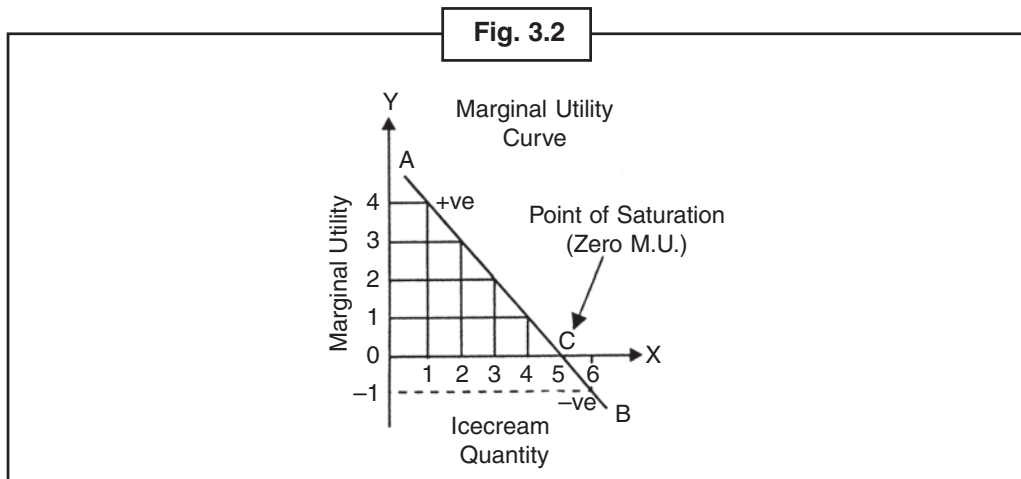

**Self Assessment**

Multiple choice questions:

- ..... has developed the theory of the Diamond-Water Paradox.
  - Adam Smith
  - Samuelsson
  - Marshall
  - Boulding
- A price for a commodity, is not equal to its total utility but is equal to its ..... utility.
  - marginal
  - total
  - difference
  - additional
- The Law of Diminishing Marginal Utility is the ..... of utility analysis.
  - foundation stone
  - saving
  - income
  - price

7. Marginal utility of the every commodity is .....
- (a) dependent                      (b) big                                      (c) independent                      (d) small

### Exceptions

According to some economists following are the exceptions to the law of diminishing marginal utility. It means that the law does not apply under the following situations. But a thorough study reveals that the exceptions are more clear than real.

- 1. Curious and Rare Things:** It is said that this law does not apply to curious and rare things. The persons who collect old and rare coins, postage stamps as increasing marginal utility as the stock of these rare articles goes on increasing. They are always keen to obtain more and more units of such things. But this exception is not true. Whereas after collecting number of stamps of the same kind the marginal utility diminishes.
- 2. Misers:** It seems law does not apply to misers who want to acquire more and more of wealth. Their desire for money seem to be insatiable. But according to **Meyers** even this exception is not true. The amount of money a miser spends on food and clothing but he cannot spend on Gold and silver. It proves that a miser who has large stock of bullions (Gold and silver) , the utility of the gold and silver gets diminished and that of food and clothing whose stock is limited, increases.
- 3. Good Book or Poem:** It is said that by reading a good book or listening to a melodious song and a beautiful poem again and again one gets more utility than before. So good books and poems are considered exceptions to this law. But it is not true. It is possible that up to a certain limit reading a good book or listening to a song again and again may increase the marginal utility but reading a good book or listening to a song at a given period of time may bring a sense of bored feeling in mind, which may lead to diminish the marginal utility.
- 4. Drunkards:** It can be said that when a drunkard takes a liquor and intoxicant then as he takes more and more pegs of liquor his desire to have more of it goes on increasing. So a drunkard is regarded as an exception to this law. However, even in case of drunkard, a stage comes when he loses his sense and starts suffering pointing to negative impact of the successive drinking the law ultimately holds goods.
- 5. Initial units:** When the initial units of a commodity are used in less than appropriate quantity, then the marginal utility from the additional units goes on increasing. According to **Benham** to heat up furnace we use coal piece, the marginal utility of the additional coal increases because the furnace requires adequate initial supply of coal. But this exception is also not correct. As we make adequate quantity of initial supply of coal then every additional unit of coal will yield less and less marginal utility.

In concise **Prof. Taussig** has rightly said that the tendency of law of diminishing marginal utility is so widely prevalent that it would not be wrong to call it as universal law.

### 3.8 Derivation of Consumer's Demand Curve Through the Law of Diminishing Marginal Utility

The price that the consumer pays is equal to the marginal utility. According to law of diminishing marginal utility, as a consumer goes on buying more and more units of commodity its marginal utility goes on diminishing. As such the consumer will buy more and more units of commodity when its price goes down. Even marginal utility is expressed in terms of money, in that situation the positive part of the marginal utility is the demand curve. In the words of **Lipsey**, "When the consumption of all but one product is held constant, the marginal utility schedule for the variable product is the product's demand curve."

When the marginal utility is shown on OY-axis then the curve obtained will be the marginal utility curve, in case price is shown in OX-axis then the curve obtained will be called marginal utility curve as indicated in the Fig. 3.3(A) and 3.3(B).



Notes

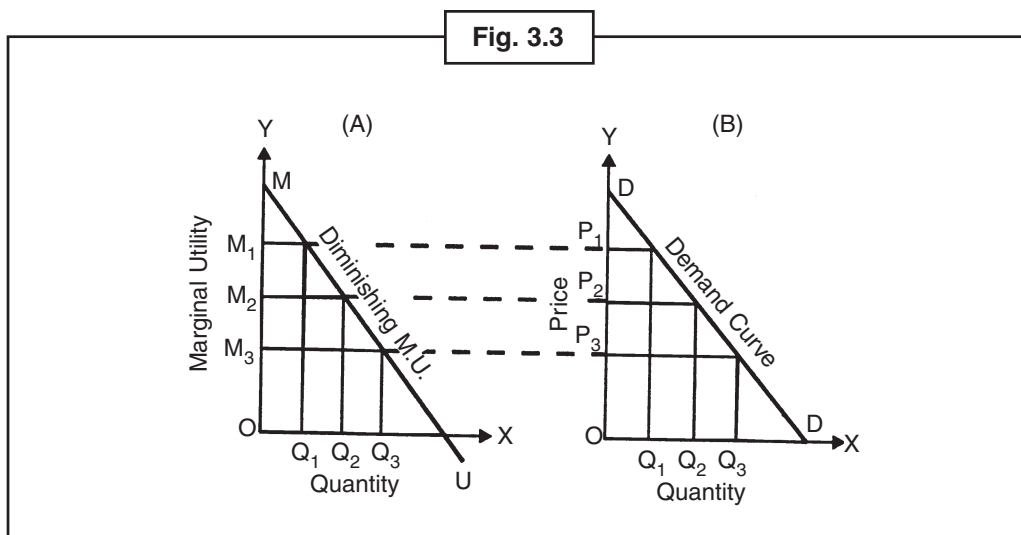

Figure 3.3(A) represents marginal utility curve and Fig. 3.3(B) represents demand curve, DD (demand curve) has been drawn with the help of marginal utility curve.

### 3.9 Law of Equi-Marginal Utility or Utility Analysis and Consumer's Equilibrium

Law of Equi-Marginal Utility is the second law of marginal utility analysis. This law points out how a consumer gets maximum satisfaction out of his given expenditure on different goods. In 19th century, this law concerning the expenditure of a consumer was first propounded by a French engineer, **Gossen**. So this law is also known as "Second law of Gossen". **Dr. Marshall** has called it "Law of Equi-Marginal utility". The law states that in order to get the maximum satisfaction a consumer should spend the limited income on different commodities in such a way that the last rupee spend on each commodity yield him equal marginal utility. Economists have given different names to this law. **Lewftwich** calls it "The General Principle for Maximisation of Consumer's Satisfaction". In simple words, it is also known as Law of Maximum Satisfaction because a consumer by spending his income in accordance with this law consumer gets maximum satisfaction. **Prof. Hibdon** has called it "law of rational consumer". A rational consumer using his rationality will spend his income strictly according to this law, so it is also known as "Law of Substitution". A consumer will go on substituting the goods yielding higher marginal utility for the goods yielding lower marginal utility till the time the marginal utility of both the goods become equal. **Lord Robbin** called it "Law of Economics" because it is applied to all the sections of study of the economics such as production, consumption, exchange distribution and public finance.

**If a person has a thing which he can put to several uses he will distribute it among these uses in such a way that it has the same marginal utility in all.**

– Marshall

**The law of equi-marginal utility states that to maximise utility, consumers must allocate their limited income, among goods in such a way that marginal utilities per dollar of demand from the last unit consumed are equal among all goods.**

– McConnell

**A consumer gets maximum satisfaction when the ratio of marginal utilities of all commodities and their prices is equal.**

– Samuelson



$$\frac{MU_1}{P_1} = \frac{MU_2}{P_2} = \frac{MU_3}{P_3}$$

If prices of the commodities are equal, the maximum satisfaction to the consumer can be indicated in the following equation.

$$MU_1 = MU_2 = MU_3$$

In the above equation  $MU_1 = MU_2 = MU_3$  refers to the marginal utility of the first, second and third commodity and  $P_1, P_2, P_3$  refer to the price of the first, second and third commodity.

### Assumptions

Law of Equi-Marginal Utility is based on the following assumptions –

- (1) Utility can be measured in the Cardinal number system.
- (2) Consumer is rational that is he wants maximum satisfaction from his income.
- (3) There is no change in the income of consumer.
- (4) Marginal Utility of money remains constant.
- (5) There is no change in the price of commodity and its substitutes.
- (6) Every unit of the commodity being used is of same quality and size.
- (7) Law of diminish marginal utility is applicable here.

### Explanation

The law can be explained with the help of the Table 3 and Fig. 3.4. Assume that an income of a person is ₹ 5.00 only. He wants to spend on two commodities say mango and milk. Also assume that the price of these two commodities is ₹ 1 per Kilo/Litre. The marginal utilities of different unities of mangoes and milk are shown in below Table 3.

Rupee Spent	M.U. of Mangoes	M.U. of Milk
First	12	10
Second	10	8
Third	8	6
Fourth	6	4
Fifth	4	2

Assume that the consumer spends his income in terms of one-rupee unit. The first rupee spent on mangoes yields him 12 units worth of marginal utility and the first rupee spent on milk yields him 10 units worth of marginal utility. Hence he will spend first rupee on mangoes. Out of 2nd and 3rd rupee he will spend one in mangoes and milk. Thus to get the total satisfaction the consumer will spend ₹ 3 on mangoes and ₹ 2 on milk out of his total income. Third rupees spend on mangoes yield him 8 units while 2nd rupee spend on milk will yield him 8 units worth of marginal utility. Thus the last units of money spend on both the commodities give the consumer the equal marginal utility. This mode of distribution would yield the consumer the maximum satisfaction. Utilities from mangoes are 30 units (12 + 10 + 8) utility from milk is 18 (10 + 8). The total utility is 48 (30 + 18). If the consumer spends his income in other manner, then he will get less total utility.

Assume that the consumer spends ₹ 4 i.e one rupee more on mangoes and ₹ 1 less in milk. By spending ₹ 1 more in mangoes the consumer will get 6 units of the utility while spending ₹ 1 less in milk. The consumer will loss 8 units of the utility.

**Notes**

In this mode of distribution of income the consumer by spending ₹ 4 one mango gets 36 (12 + 10 + 8 + 6) units and by spending only ₹ 1 on milk the consumer will get 10 units of utility. If the consumer spends his earning in this manner then he will able to get total utility of 36 + 10 = 46 units.

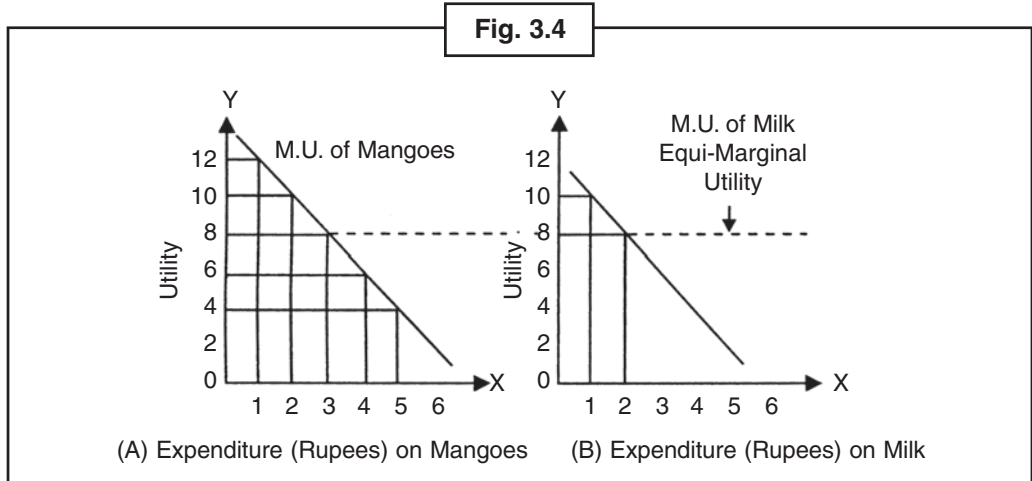

This total utility is less by 2 units as compared to the total utility (48) derived from the previous distribution of income. Thus other distributions of income will yield the consumer as much satisfaction as the one in which the last unit of rupees spent on different commodities gives equal marginal utility.

In the Fig. 3.4(A) and 3.4(B) units of rupees are shown in OX-axis and Marginal Utility in the OY-axis. In Fig. 3.4(A) the marginal utility of the mangoes is shown while in Fig. 3.4(B) the marginal utility of the milk is shown. The figure indicates that if the income of the consumer is ₹ 5 then he spent ₹ 3 on mangoes and ₹ 2 on Milk as the third rupee he spends on the mangoes and the second rupee he spends on the Milk gave him the equal marginal utility i.e 8 units. Dotted line in the figure represents equal marginal utility derived from the last unit of rupee spend on the two commodities -mangoes and milk. By distributing his income on these two commodities in this manner the consumer gets total utility of 48 units. It is the maximum total utility that the consumer is getting out of his expenditure of ₹ 5. And this manner of spending has given the consumer a sense of total satisfaction.

If the consumer spends his income on these two commodities mango and milk in other manner then his total utility will be less than the maximum. The below Fig. 3.5 explains the same.

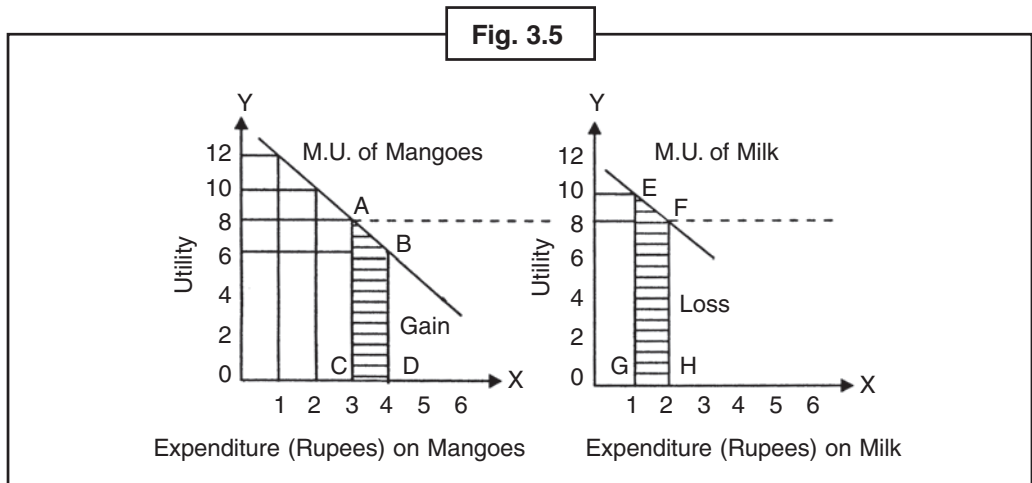

It is proved from the Fig. 3.5 that by spending ₹ 1 more on mango, the consumer gains 6 units of marginal utility as shown by ABCD area. Similarly, by spending ₹ 1 less on milk the consumer loses 8 units of marginal utility as shown by EFGH area. By this distribution of income the consumer will get 2 units of the total utility less. The consumer now gets only 46 units of the total utility while the earlier spending manner will give him 48 units of the total utility.

### 3.10 Modern Statement of the Law

Modern economists call this law as **Law of Proportionality**. According to them a consumer gets the maximum satisfaction when the ratio of marginal utilities derived from different goods and this cost is equal. Assume that the price of an apple is 50 paise and a consumer buys 10 apples. He gets 6th util from 10th apple. The marginal utility per rupee from the 10th apple and be calculated with the help out –

$$\frac{MU_a}{P_a} = \frac{6}{0.5} = 12 \text{ Util per ₹.}$$

(Here  $MU_a$  = Marginal Utility of apples and  $P_a$  = Price of the apple per unit)

Similarly, if the price of banana is 25 paise per piece, as consumer buys 12 bananas. He gets 3 units of the marginal utility from the number 12th banana. The marginal utility per rupee from the 12th banana and be calculated with the help out following formula –

$$\frac{MU_b}{P_b} = \frac{3}{0.25} = 12 \text{ Util per ₹.}$$

(Here  $MU_b$  = Marginal Utility of Bananas and  $P_b$  = Price of the Bananas)

In the above example the consumer gets equal marginal utility per rupee from both the goods. In this condition he will not stand to gain, if he spends one more in one commodity and one less in other commodities. He would not like to make any change in his expenditure. Therefore, the consumer will be in the state of maximum satisfaction under the following situation.

$$\frac{MU_a}{P_a} = \frac{MU_b}{P_b} \text{ or } \frac{MU_a}{P_a} = \frac{P_a}{P_b}$$

In short, the consumer will buy so much quantity of different goods that will make their ratio of their marginal utilities and price equal, by spending his income in this manner the consumer will get maximum satisfaction. If a consumer is to buy "n" commodities, then by using the below written formula, he will get maximum satisfaction out of his expenditure-

$$\frac{MU_a}{P_a} = \frac{MU_b}{P_b} = \frac{MU_c}{P_c} \dots\dots\dots \frac{MU_n}{P_n}$$

### 3.11 Importance of the Law

Importance of the Law is of great importance in economics. **Robbins** regards it as the basis of economics. According to **Marshall**, "The application of the principle of equi-marginal utility extends over almost every field of economic enquiry."

For Example –

- 1. Consumption:** Every consumer wants to get **maximum satisfaction** from his limited means. As suggested by this law if a consumer spends his income on different commodities in such a way that last unit of money spent on commodities yields him **equal marginal utility** then it will give him maximum satisfaction.
- 2. Production:** Every producer aims at earning maximum profit. In order to achieve its satisfaction a producer has to utilize different factors of production such as land, labor, capital, etc. in such a manner

Notes

that the marginal factor of each factor is equal. A producer must go on substituting various factors until **marginal productivity** of each factor is equal. A producer can succeed in his aim of getting maximum satisfaction only when he adjusts his limited resources.

3. **Exchange:** Exchange means replacement of goods giving less utility with goods giving more utility. Acting upon the law every person will go on substituting goods giving more utility for the ones giving less utility, **till the marginal utility of all becomes equal**. Exchange will stop at this point. Money should be also exchanged for other goods and services up to the mark where the marginal utilities of the goods or the services are equal to the marginal utility of the money to be spent on them.
4. **Distribution:** It refers to the distribution of national income among the factors of production that are land labour, capital etc. it is done in such a way that in the long run every factor gets share out of national income according to its **marginal utility**. In order to have such distribution factors are to be mutually replaced in a manner that the marginal productivity of each factor is equal to its remuneration, and the marginal productivity of the different factors becomes equal to each other.
5. **Public Finance:** The law also has importance in this sphere of public finance, that revenue and expenditure of the state. At the time of levying taxes finance minister takes its help. He levies the tax in such a way that the marginal sacrifice of each tax payer is equal. Then only it has least burden on the tax payers. In order to achieve this objective a finance minister may substitute one tax for others. Similarly, at the time of spending public fund it is ensured that the marginal benefit of each type of expenditure should be equal. When the marginal social sacrifice made by the people in the form of payment of the taxes is equal to the marginal social benefit derived by them out of the public expenditure, then the country can enjoy maximum social advantage.
6. **Distribution of income between saving and consumption:** According to this law, income should be distributed between consumption and saving that the last unit of money spent on present consumption should yield the same utility as the last unit of money kept in the form of saving. Such a distribution is called optimum allocation.
7. **Optimum distribution of commodities:** Optimum distribution of the commodities is possible with this law in a free market economy. Optimum distribution of commodities refers to that distribution, a slight change whereof may diminish the total utility enjoyed by society as a whole. **Optimum distribution becomes possible when a commodity is distributed among different persons in such a way that marginal utility derived from each person becomes equal.**
8. **Distribution of assets:** Distribution of assets helps people distribute their assets in different forms. Suppose a person has cash of 1 lakh . He wants to invest in different forms bank deposit, bond, stock shares, housing etc. According to this law, investment should be made in different, forms of assets in such a way that last unit of money invested in each form should yield equal marginal utility. Thus he will derive almost equal psychological benefit from all forms of assets and thereby enjoys maximum satisfaction.



Task

Give your opinion on importance of the law.

### 3.12 Criticisms of the Law

1. **Consumers are not Fully Rational:** The assumption that consumers are not fully rational is not correct. Some consumers are idle by nature, and so to satisfy their habits and customs, they sometimes buy goods yielding less utility. Eventually, they do not get maximum satisfaction.

2. **Consumer is not Calculating:** The law is based on wrong assumption that while spending his income a consumer constantly calculates the utility derived by him out of each rupee spent. Another wrong assumption of this law is that consumer goes on comparing the marginal utilities of the last rupee spent on different commodities. In actual life one hardly comes across such a calculating consumer. So the application of this law is practically difficult.
3. **Non-availability of Goods:** If goods giving more utility are not available in the market, the consumption will have to consume goods yielding less utility. If there is non availability of cooking gas in the market then the consumer will go for other options either coal or kerosene oil. If the utility of the later, coal or kerosene oil is less then the consumer will not get the maximum satisfaction.
4. **Ignorance of the Consumer:** Consumer is ignorant about concerning consumption. He is ignorant about right price of goods, less expensive substitute of the goods and of the different uses of goods. Due to these factors, the consumer fails to spend his income in a manner that may yield him maximum satisfaction.
5. **Indivisibility of Goods:** The law is not applicable to those goods which cannot be divided into small parts, Things like car, Television set, scooter have to be bought at least in one unit. To equalize the marginal utility of different goods , if we are thinking to buy one unit of above goods, then we may not be able to buy the additional unit. So we can say that this law does not apply to invisible goods.
6. **No definite budget period:** Another limitation of this law is that the budget period of consumer is not definite. A consumer has to spend his income of different uses within a definite period of time which is also known as budget periods and that budget period can be a month or a year. Goods like TV Set, refrigerator are bought in one budget period, but they continue to yield utility over many budget periods. Marginal utility of those items such as TV set, refrigerator cannot be compared with those commodities which are bought and consumed in the same period.
7. **Cardinal measurement of utility is not possible:** Utility cannot be measured in cardinal number system. How can a consumer say he would get 12 units of utility from first mango and 10 units from second. Unless the marginal utility is estimated application of the law remains dubious.
8. **Change in the marginal utility of money:** The assumption that the marginal utility of the money remain constant is also not realistic in nature. In actual life marginal utility of money may increase or decrease. When a consumer buys more goods, he is left with less amount of money. As the marginal utility of the less money is higher, the consumer has to arrange his expenditure on different goods. Smaller the amount of money higher is its marginal utility. As a result of it, application of the law will become pretty difficult.
9. **Complementary goods:** The law does not apply to complimentary goods because they are used in fixed proportion. By using less of one commodity, use of the other cannot be increased. For example, one cannot use tape recorder without a cassette and a camera without a reel. One has to buy the both to bring its utility.

*In reality though there are limitations with this law, but it is true that Law of Equi-Marginal Utility is only the law in economics. This law in actual describes how to get the maximum satisfaction from a limited income.*

In short, Chapman has rightly said about this law, “We are not, of course, compelled to distribute our income according to the law of substitution or Equi-marginal expenditure, as a stone thrown in the air is compelled to, in a sense to fall back to the earth but as a matter of fact, we do so in a certain rough fashion because we are reasonable.”

### Self Assessment

State whether the following statements are True/False:

8. Law of Equi-Marginal Utility has great importance in geography.
9. Every producer aims at earning maximum profit.

- Notes**
10. Distribution means the distribution of national income among the factors of production.
  11. Every consumer wants to get the maximum satisfaction from a limited income.
  12. Consumer is ignorant about many things concerning consumption.

### 3.13 Consumer's Surplus: An Illustrative Description

We know that a consumer wishes to pay equal to marginal utility of the commodity. (Means wants to pay that sum of amount which is equal to the marginal utility of the goods.) We also know that marginal utility of the commodity tends to decrease as more and more of it is purchased. So, for this reason the demand curve of the commodity slopes from left to right. In fact, the marginal utility curve (showing inverse relation between quantity of the commodity and the marginal utility) is a synonym of demand curve showing inverse relation between price and quantity of the commodity as the price of the commodity is equated with marginal utility of that commodity. For each successive unit the consumer in tends pays less every time equating price with the diminishing marginal utility of the commodity. However, each unit of the commodity cannot be purchased at different prices. Implying that for certain units he must intend to pay more what he actually pays. The sum total of the difference between what he actually intends to pay and what he actually pays, is what is called consumer's surplus.

#### Illustration

The below explains the consumer surplus of a consumer:

Table 4				
<i>X Unit</i>	<i>MU<sub>X</sub></i>	<i>P<sub>X</sub> or price the consumer is ready to pay (₹)</i>	<i>Actual price</i>	<i>Consumer surplus (intended price-actual price)</i>
1st	100	10	4	10 - 4 = 6
2nd	80	8	4	8 - 4 = 4
3rd	60	6	4	6 - 4 = 2
4th	40	4	4	4 - 4 = 0

Consumer surplus is  $6 + 4 + 2 = ₹ 12$ .

(Note: the marginal utility of the money is 10 units and is constant.)

The Fig. 3.6 shows that the consumer intends to pay for every successive units of a commodity. He intends to pay  $L, L_1, \dots, L_6$  which means that in accordance to consumer rationality he pays equal to the marginal utility of the commodity. As the marginal utility tend to decrease with every unit of commodity, consumer demands more unit of the commodity at low price. If the total purchase is OS, then the consumer intends price is equal to area  $OSL_6L$  ( $OSL_6L$  area is the area which is obtained by adding up price for each unit that the consumer intends to pay). The total actual price the consumer has to pay is  $OS \times OP = OSL_6P$ .

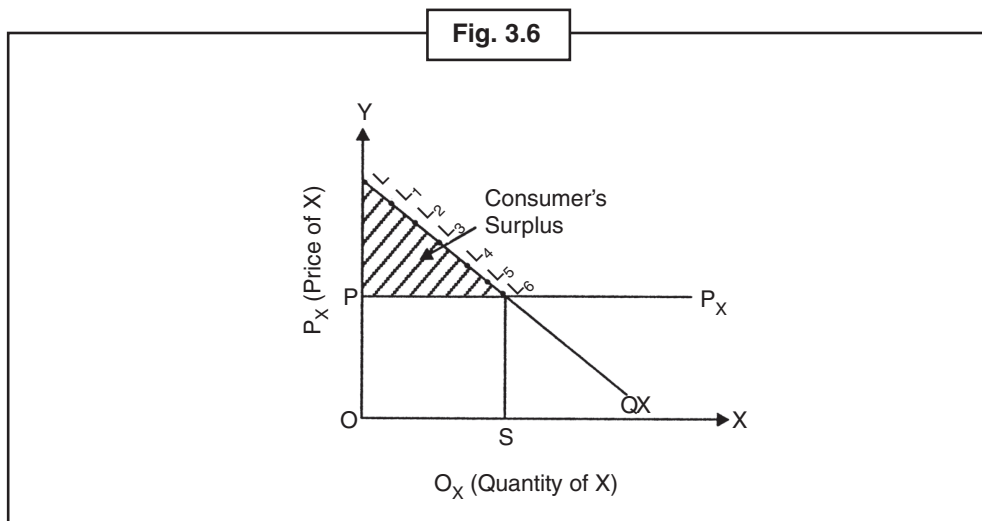

Accordingly,

$$\begin{aligned} \text{Consumer surplus} &= \text{OSL}_6\text{L (Total Intend Price)} - \text{OSL}_6\text{P area (Total Actual Price)} \\ &= \text{PL}_6\text{L area} \end{aligned}$$

In other words consumer surplus =  $\text{OSL}_6\text{L} - \text{OSL}_6\text{P} = \text{PL}_6\text{L}$

### 3.14 Summary

- Law of Equi-marginal utility explains how a consumer gets maximum satisfaction out of the expenditure on different goods. This law was first propounded in 19th century by a French engineer **Gossen**. Therefore it also known as “**Second Law of Gossen**”. **Dr Marshall** called it “**Law of Equi-Marginal Utility**.” The law states that in order to get the maximum satisfaction, a customer should spend his given income on different commodities in such a way that the last rupee spent on each commodities yield him equal marginal utility. Economists have called it differently.

### 3.15 Keywords

- **Marginal Utility:** Extra Utility
- **Assumptions:** Opinion
- **Consumer:** One who consumes goods
- **Law:** Regulation

### 3.16 Review Questions

1. What is utility? Explain.
2. What are the differences between total utility and the marginal utility?
3. What are tame laws of equi-marginal utility?
4. Explain “Consumer Surplus”.



Notes

**Answers: Self Assessment**

- |                 |          |               |          |
|-----------------|----------|---------------|----------|
| 1. Satisfaction | 2. Util  | 3. Additional | 4. (a)   |
| 5. (a)          | 6. (a)   | 7. (c)        | 8. False |
| 9. True         | 10. True | 11. True      | 12. True |

**3.17 Further Readings**



*Books*

1. **Microeconomics: Principles, Applications and Tools**—*Sanjay Basotiya, DND Publications, 2010.*
2. **Microeconomics**—*Frank Cowell, Oxford University Press, 2007.*
3. **Microeconomics**—*Robert S. Predik, Daniel L Robinflod and Prem L. Mehta, Pearson Education, 2009, PBK 7th Edition.*

## Unit-4: Ordinal Utility Theory: Indifference Curve Approach

### CONTENTS

Objectives

Introduction

- 4.1 What is an Indifference Curve?
- 4.2 Indifference Schedule
- 4.3 Graphical Presentation of Indifference Curve
- 4.4 Indifference Map
- 4.5 Constant Marginal Rate of Substitution
- 4.6 Why does the Marginal Rate of Substitution Diminish?
- 4.7 Comparison of the Law of Diminishing Marginal Utility and the Law of Diminishing Marginal Rate of Substitution
- 4.8 Assumptions of Indifference Curve Analysis
- 4.9 Properties of Indifference Curves
- 4.10 Some Exceptional Shapes of Indifference Curves
- 4.11 Budget Line or Price Line
- 4.12 Properties of Budget Line
- 4.13 Shifting of the Budget Line or Price Line
- 4.14 Consumer's Equilibrium
- 4.15 Two Basic Conditions of Consumer's Equilibrium
- 4.16 Effect of Change in Commodity Price on Consumer's Equilibrium
- 4.17 Price Effect
- 4.18 Income Effect
- 4.19 Substitution Effect
- 4.20 Identification of Substitution Effect and Income Effect of Splitting Price Effect into Substitution Effect and Income Effect
- 4.21 The Hicksian Approach
- 4.22 Giffen's Paradox

**Notes**

- 4.23 Income and Substitution Effects in Case of Giffen Goods
- 4.24 Possible Combinations of Income and Substitution Effects
- 4.25 The Slutsky's Approach
- 4.26 How Slutsky's Approach Differs from Hicks' Approach
- 4.27 Price Consumption Curve
- 4.28 Explanation
- 4.29 Slope of PCC Curve
- 4.30 Derivation of Demand Curve Through Indifference Curve Analysis or Through Price Consumption Curve
- 4.31 Difference between Demand Curve and Price Consumption Curve
- 4.32 Income Consumption Curve
- 4.33 Slope of the Curve
- 4.34 Engel's Curve
- 4.35 Criticism of Demand Theory
- 4.36 Alleged Exceptions to the Law of Demand
- 4.37 Demand Theory is Unrealistic: Consumer Behaviour Contradictory to Demand Theory
- 4.38 Summary
- 4.39 Keywords
- 4.40 Review Questions
- 4.41 Further Readings

**Objectives**

After studying this unit, students will be able to:

- Know the Derivation of Demand.
- Understand the Marginal Substitution Effect.
- Study the Price Effect.
- Know the Demand Theory.

**Introduction**

Utility analysis is based on the recognition that the cardinal measurement of utility of product is possible which means utility can be described by cardinal numbers 1, 2, 3, 4, 5..... etc. But this is not

a practical description. There is no parameter by which we can know the satisfaction to buy or use of a product. But consumers can compare the satisfaction with various products or from various units of a product. This is called the ordinal measurement of utilities. For example, if you use a cup of tea and a cup of coffee then you can only say that from which cup you get maximum satisfaction. But you cannot describe this satisfaction with cardinal numbers like 50 units or 40 units. Ordinal word means to put ranking as first, second, third, etc. Indifference curve analysis is based on the ordinal measurement of utility.

Marginal curve analysis was first proposed by English economist **Edgeworth** in 1881 in his book 'Mathematical Psychics'. This concept was developed by Italian economist, **Pareto** in 1906, by British economist **W. E. Johnson** in 1913 and by Russian economist **Slutsky** in 1915. The credit of rendering this analysis as an important tool in demand theory goes to Hicks and Allen in 1934. They have presented this scientifically in their article, 'A reconsideration of the theory of value.' **Hicks** has discussed it in detail in his book 'Value and Capital'.

#### 4.1 What is an Indifference Curve?

Indifference curve is that curve that represents those various combinations of two commodities that provides equal satisfaction to consumers. This means that all the points located on the indifference curve represent those combinations of two products that provide equal satisfaction to consumers. As the combinations represented by all the points yield same satisfaction, the consumers, therefore, become indifferent in their choice i.e. gives equal importance to all combinations on the indifference curve.

**H. L. Varian** opines, "An indifference curve represents all combinations of two commodities that provide the same level of satisfaction to a person. That person is therefore, indifferent among the combinations represented by the points on the curve."

##### The Meaning of Indifference is Lack of Difference

*Commodity X and commodity Y have two different combinations  $X_1, Y_1$  and  $X_2, Y_2$  which give same satisfaction to the consumer. Consumer will be indifferent in relation to these combinations i.e. there will be no difference between the combinations  $X_1, Y_1$  and  $X_2, Y_2$  for him, in content of level of satisfaction.*

*Indifference curve is that curve which represents those various combinations of commodity X and Y which provide him same satisfaction.*

According to **Koutsoyiannis**, "An indifference curve is the locus of points, particular combination of goods, which yield the same utility to the consumer, so that he is indifferent as to the particular combinations he consumes."

#### 4.2 Indifference Schedule

An indifference schedule refers to that schedule which indicates different combinations of two commodities which yield equal satisfaction. A consumer, therefore, gives equal importance to each of the combinations. In other words, he becomes indifferent towards them. In the words of **Meyers**, "An indifference schedule may be defined as a schedule of various combinations of goods that will be equally satisfactory to the individual concerned."

The following (pg. 44) schedule indicates different combinations of apples and oranges that yield equal satisfaction to the consumer.

Notes

Table 1: Indifference Schedule		
Combination of Orange and Apple	Apples	Oranges
A	1	10
B	2	7
C	3	5
D	4	4

The above schedule shows that the consumer gets equal satisfaction from all the four combinations A, B, C, D of apples and oranges. In combination A, the consumer has 1 apple plus 10 oranges, in combination B, he has 2 apples plus 7 oranges, in combination C, he has 3 apples plus 5 oranges and in combination D, he has 4 apples plus 4 oranges. The consumer in order to have more apples, sacrifices some quantity of oranges in such a way that there is no change in the level of satisfaction out of each combination.

### 4.3 Graphical Presentation of Indifference Curve

Indifference curve is graphical presentation of indifference schedule. Based on table 1, indifference curve is shown in Fig. 4.1. In this diagram, quantity of apple is shown on axis OX and quantity of orange is shown on axis OY. IC is an indifference curve. Different points A, B, C and D on it indicate those combinations of apples and oranges which yield equal satisfaction to the consumer. Therefore, it is also known as **Iso-utility curve**.

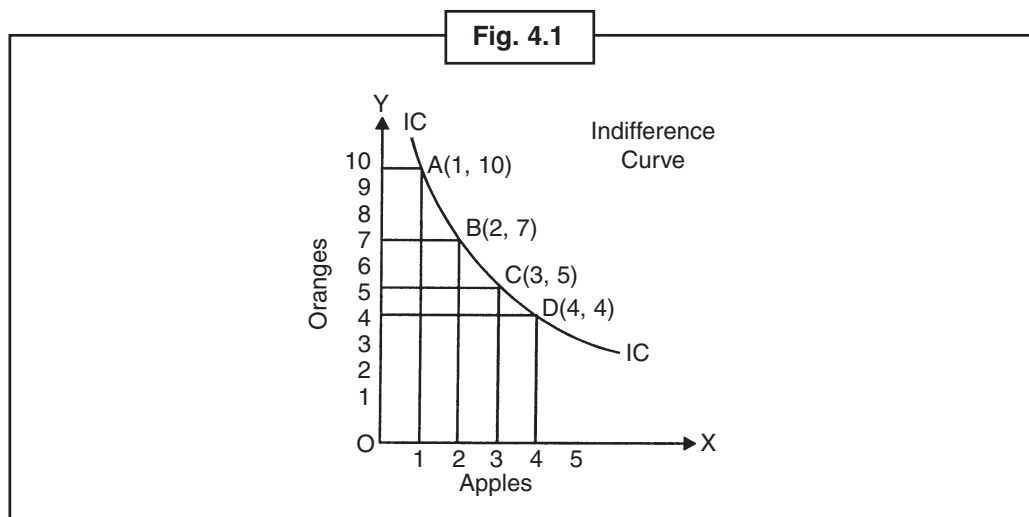

#### Self Assessment

Fill in the blanks:

1. Indifference means ..... from one point to another on a curve itself.

2. Preference means shifting from lower ..... curve to higher indifference curve.
3. Higher indifference curve represents higher level of .....

Notes

### 4.4 Indifference Map

An indifference curve indicates different combinations of two commodities which yield a given level of satisfaction to the consumer. In order to indicate higher or lower level of satisfaction of different combinations of different products, we have to make use of different indifference curves. When these indifference curves their groups are shown by a diagram, then it is called indifference map. Thus indifference map is that graph which represents a group of indifference curves each of which expresses a given level of satisfaction. In Fig. 4.2, indifference map is shown. In the diagram quantity of apples is shown on axis OX and quantity of oranges is shown on axis OY.  $I_1, I_2, I_3$  and  $I_4$  are different indifference curves. Each indifference curve is representing different level of satisfaction. As an indifference curve shifts to the right, the level of satisfaction goes on increasing. In this diagram  $I_4$  represents the combination yielding maximum satisfaction. Combination of  $I_3$  curve yields less satisfaction than combination of  $I_4$ .  $I_1$  curve represents the combination yielding least satisfaction. For instance, in Fig. 4.2 at point D of  $I_2$ , a consumer consumes 4 apples plus 4 oranges. If the consumer consumes 4 apples plus 5 oranges, naturally his level of satisfaction will be more and in this way he will shift to point F of  $I_3$ . Similarly if the consumer consumes 6 apples plus 4 oranges, his level moves to point G of  $I_3$ . So we can say that point F and G which lie on the indifference curve  $I_3$  yield more level of satisfaction than point D which lies on  $I_2$ . If consumer consumes 8 apples plus 4 oranges, his satisfaction will be more than at point G and he will move to point E of  $I_4$ . Thus, from the point of view of satisfaction  $I_4 > I_3 > I_2 > I_1$ . In other words, any indifference curve which will be right to another will be called higher indifference curve and will yield higher satisfaction. Any combination located on the higher indifference curve will be liked more than any combination of lower indifference curve.

An indifference curve right and higher than another indifference curve represents higher level of satisfaction. **Indifference** means mobility from one point to another on a curve itself but **Preference** means shifting of lower indifference curve to higher indifference curve. The reason is that higher indifference curve represents higher level of income.

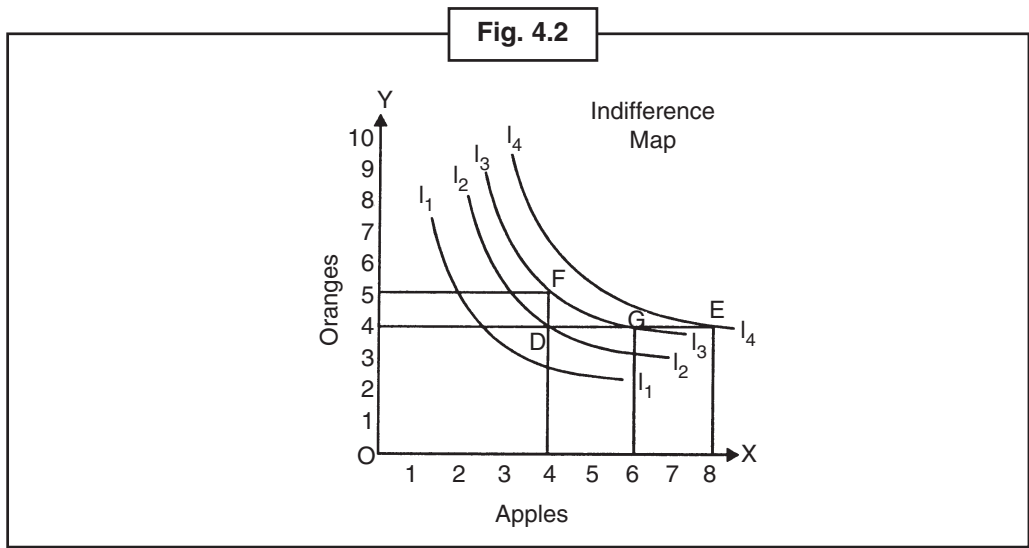

## Notes

**4.5 Constant Marginal Rate of Substitution**

One learns from the study of indifference curve that when a consumer gets one more unit of X commodity, his satisfaction increases. If the consumer wants his level of satisfaction to be the same, means if he wants to remain on the same indifference curve, he will have to give up some units of commodity Y. In other words, in exchange of the satisfaction obtained from the additional apple, he will have to give up that quantity of oranges whose satisfaction is equal to the additional satisfaction obtained from an additional apple.

*The marginal rate of substitution decides the slope of indifference curve. The stable marginal rate means stability of sloping or marginal rate is a line of indifference curve. The decrease marginal rate of substitution means falling of slope or convex indifference curve means convex to the main point.*

**Satisfaction Gained of Apples = Satisfaction Lost from Oranges**

In order to get one more unit of apple, a consumer gives up three units of oranges, it means, he substitutes one apple for 3 oranges, then it will be said that satisfaction derived from one apple is equal to the satisfaction of 3 oranges. So the marginal rate of substitution for apple to oranges is 1:3. In this way, it can be said that the marginal rate of substitution of apple for orange is the number of oranges that will be given up for obtaining each additional unit of apple, so that the satisfaction of the consumer remains the same. In other words, marginal rate of substitution (MRS) is the rate at which the consumer can substitute one product for another without changing the level of satisfaction. It indicates the slope of indifference curves.

According to Bilas, "The marginal rate of substitution of product X for product Y ( $MRS_{xy}$ ) is defined as the amount of Y, the consumer is just willing to give up to get one more unit of product X and maintain the same level of satisfaction."

$$MRS_{xy} = \frac{\text{Loss of Y}}{\text{Gain of X}} = (-) \frac{\Delta Y}{\Delta X}$$

Where  $MRS_{xy}$  is marginal rate of substitution of X for Y;  $\Delta Y$ , changes in commodity,  $\Delta X$  = changes in commodity -X.

In other words, if consumer wants to maintain same level of satisfaction, then marginal rate of substitution is that ratio of quantities of commodity Y and commodity X which have to necessarily be given up for getting one more unit of commodity X. This ratio is normally negative as change in commodity Y with the increase in commodity X is negative.

**(i) Constant Marginal Rate of Substitution**

Marginal Rate of substitution is constant when in order to get one more unit of commodity X only one unit of commodity Y has to be sacrificed so that level of satisfaction remains the same. In other words, rate of substitution is equal. Marginal rate of substitution of perfect substitute goods is equal.

**Constant Marginal Rate of Substitution is only a Theoretical Possibility**

*When commodity X is substituted for commodity Y at an increasing rate, then quantity of Y reduces and quantity of X increases with the consumer. When the quantity of commodity X increases with the consumer, then every additional unit gives more satisfaction from the previous units. In contrast, as a result of reduction in the units of commodity Y and because of sacrificing on additional unit of Y, there is additional loss in satisfaction. When as a result of sacrificing one additional unit of Y, the loss in satisfaction is more than the satisfaction yielded by the additional unit of X then how can there be exchange at constant rate between X and Y.*



Following can be described by Table 2 and Fig. 4.3

Notes

Table 2: Constant Marginal Rate of Substitution			
Combination	Apples	Oranges	Marginal Rate of Substitution
A	1	10	
B	2	9	1:1
C	3	8	1:1
D	4	7	1:1

Table 2 represents that to get one additional unit of apple the consumer has to sacrifice one orange. In other words, marginal rate of substitution will be equal i.e. 1:1.

Figure 4.3 shows that when consumer moves from point A to point B, he sacrifices one orange to get an additional apple. In this situation, marginal rate of substitution of apple for orange is 1:1 for consumer. Similarly, when he moves from B to C or C to D, i.e., shifts from one point to another point, then marginal rate of substitution remains the same i.e. 1:1. In this condition indifference curve will be downward sloping on straight line from left to right as shown in Fig. 4.3

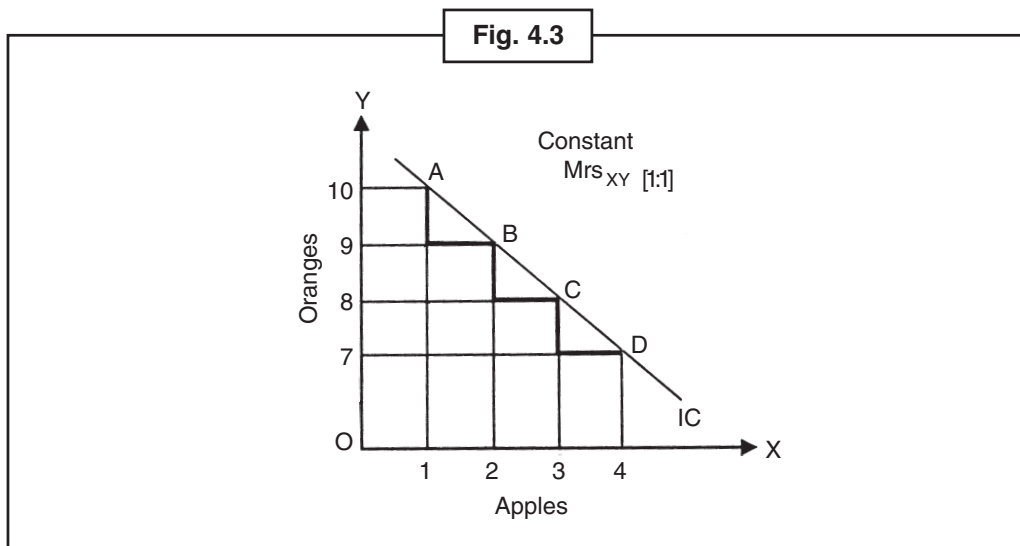

**(ii) Increasing Marginal Rate of Substitution**

Increasing marginal rate of substitution means when the stock of any product increases with the consumer, then to maintain the same level of satisfaction, he substitutes that product for another product at increasing rate. For example, to get one more unit of product X, 2 units of product Y are sacrificed and to get one more unit of X, 3 units of product Y are sacrificed. In this condition, slope of indifference curve is concave to the point of origin as shown in Fig. 4.4

**Notes** Increasing marginal rate of substitution is explained in the following Table 3 and Fig. 4.4–

Table 3: Increasing Marginal Rate of Substitution			
Combination	Apples	Oranges	Marginal Rate of Substitution
A	1	10	
B	2	9	1:1
C	3	8	2:1
D	4	7	3:1

Table 3 represents that consumer sacrifices 1 orange to get 2 units of apples, sacrifices 2 oranges to get 3 units of apples and sacrifices 3 oranges to get 4 units of apples. In other words, marginal rate of substitution of apple for orange is increasing.

Figure 4.4 represents that when the consumer purchases 2 apples, then he will purchase 9 oranges. In other words, he will sacrifice one orange to get one additional unit of apple. When he buys 3 apples, he will be able to buy 7 oranges. In other words, to get one additional unit of apple, he sacrifices 2 oranges. Similarly, when he buys 4 apples then he will buy 4 oranges means to get one more apple he will sacrifice 3 oranges. In other words, marginal rate of substitution is increasing. In this situation, indifference curve is concave to the point of origin.

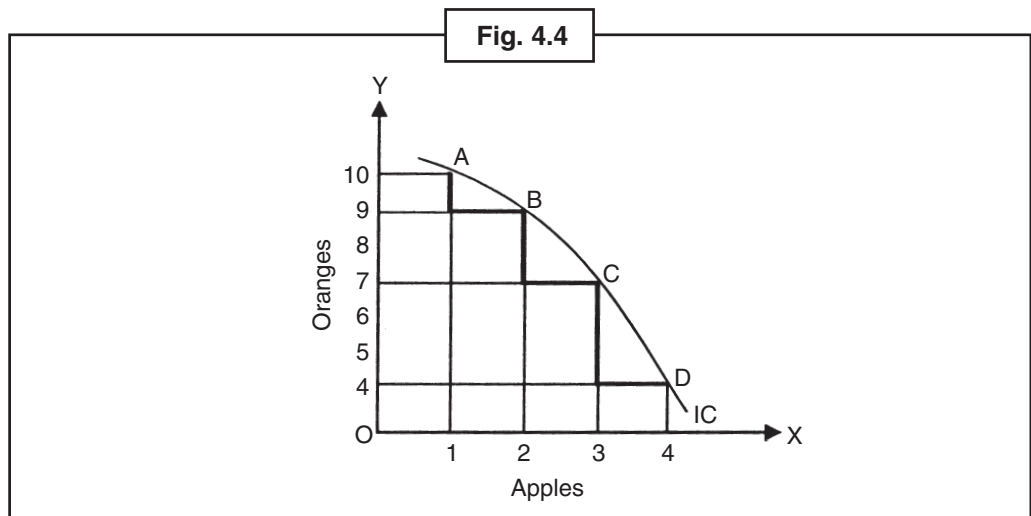

**(iii) Diminishing Marginal Rate of Substitution**

Diminishing marginal rate of substitution refers to the situation when stock of any product increases with the consumer to maintain the same level of satisfaction; he will substitute the product for another product at diminishing rate. In this condition, indifference curve is convex to the point of origin. This is a basic assumption of indifference curve; it is shown in Fig. 4.5. This is also a common characteristic and it is explained as a law below.

This law is explained in Table 4 and Fig. 4.5.

Combination	Apples	Oranges	Marginal Rate of Substitution
A	1	10	—
B	2	7	3:1
C	3	5	2:1
D	4	4	1:1

Table 4 represents that the consumer will substitute 3 oranges for 2nd apple, 2 oranges for 3rd apple and one orange for 4th apple means as he will take more number of apples, marginal rate of substitution of apples for oranges will decrease.

Figure. 4.5 shows that when consumer moves from point A to point B, then he sacrifices 3 oranges in order to get one additional unit of apple. In this condition, consumer's marginal rate of substitution of apples for oranges is 3:1. Similarly, when he moves from B to C, then in exchange of 1 additional unit of apple, he is ready to sacrifice 2 oranges it means his marginal rate of substitution is 2:1. It is evident from the example that as the consumer increases the utility of apples; he sacrifices less oranges to get every additional unit of apple it means the substitution rate is 3:1, 2:1, 1:1. Since it is really possible, so it is called law of diminishing marginal rate of substitution.

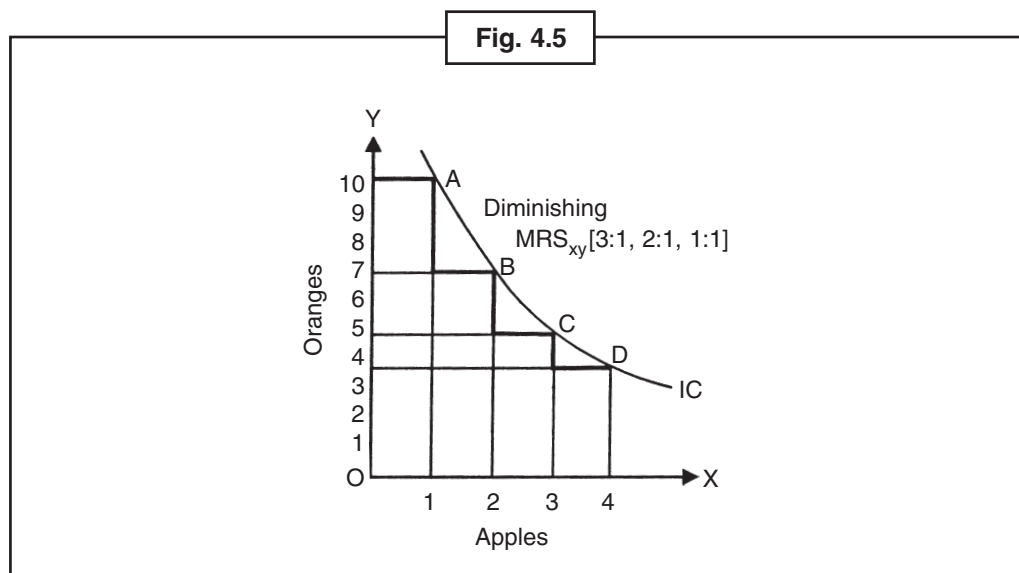

#### 4.6 Why does the Marginal Rate of Substitution Diminish?

Law of diminishing marginal rate of substitution in actual, is a wide form of law of decreasing marginal utility. According to law of diminishing marginal utility, when a consumer increases the consumption of any product then the marginal utility, received from the product, decreases and in contrast, when he decreases the consumption of any product, the marginal utility increases. Figure 4.5 shows the consumer consumes 1 apple and 10 oranges at point A. At point B, the consumer consumes 7 oranges and 2 apples means, he sacrifices 3 oranges for 1 apple. According to the law of diminishing marginal utility, marginal utility of increasing numbers of apples is decreasing and marginal utility of decreasing

**Notes**

numbers of oranges is increasing. As a result, the consumer will be ready to sacrifice less quantity of oranges respectively in exchange of every additional unit of apple. In other words, MRS of apples for oranges is decreasing causes of applicability of this law are same as that of law of diminishing marginal utility it means (i) satisfaction of particular need (ii) goods are perfectly substituted and (iii) goods have alternative uses. This law is not applicable in (i) **Perfect Substitutes** (ii) **Perfect Complementary Goods**.

### 4.7 Comparison of the Law of Diminishing Marginal Utility and the Law of Diminishing Marginal Rate of Substitution

Law of diminishing marginal rate of substitution and law of diminishing marginal utility reflect an important tendency of consumer’s behaviour. According to these laws, as the stock of goods increases at consumer, the value of extra units decreases. So the law of diminishing marginal rate of substitution is based on the law of diminishing marginal utility. But according to **Hicks**, law of diminishing marginal rate of substitution explains this tendency of consumer behaviour with fewer assumptions than the law of diminishing marginal utility. So this law is more realistic than the law of diminishing marginal utility on account of the following reasons:

**1. No need of measuring utility in Cardinal Numbers:** Law of diminishing marginal utility is based on the unrealistic assumption of cardinal measurement of utility whereas there is no need of measuring utility of cardinal numbers in the laws of diminishing marginal utility of substitution. Therefore, this law is more realistic.

**2. Free from the Assumption of Independent Commodities:** Law of diminishing marginal utility is based on the unrealistic assumption that utility derived from a particular product depends on the available quantity of product. For example, utility derived from tea will have no effect from utility derived from related product coffee. There is no need of assumption of this concept of law of diminishing marginal rate of substitution. This law takes into account the effects of relative products on each other’s utility.

**3. Free from the Assumption of Constant Utility of Money:** Law of Diminishing Marginal utility is based on unrealistic assumption that marginal utility of money is constant. There is no need for this assumption in Law of Diminishing Marginal Rate of Substitution.

But **Koutsoyiannis** believes that Marginal Rate of Substitution is placed is the concept of Marginal utility as it can be proved that marginal rate of substitution is equal to the ratio of marginal utility of goods.

$$\text{MRS}_{xy} = \frac{\text{MU}_x}{\text{MU}_y} \quad \text{or} \quad \text{MRS}_{xy} = \frac{\text{MU}_y}{\text{MU}_x}$$

### Self Assessment

**Multiple choice questions:**

4. Marginal rate of substitution determines the ..... of indifference curve.
  - (a) meaning
  - (b) slope
  - (c) satisfaction
  - (d) aim
5. Constant Marginal Substitution means the slope is .....
  - (a) unpredicted
  - (b) constant
  - (c) curve
  - (d) straight
6. Diminishing marginal substitution means the indifference curve will be .....
  - (a) convex
  - (b) curve
  - (c) constant
  - (d) unpredicted
7. Marginal rate of substitution of perfect substitute goods is .....
  - (a) not equal
  - (b) curve
  - (c) constant
  - (d) equal

## 4.8 Assumptions of Indifference Curve Analysis

Indifference Curve Analysis is based on the following assumptions:

- 1. Rational Consumer:** It is assumed that the behaviour of consumer will be rational. We assume that consumer has complete information about the circumstances related to consumption decisions. Consumer has information about every goods and services, their prices and his monetary income. Based on this information, consumer can decide which combination is better, and which of the combinations provide equal satisfaction. Every consumer will try to get maximum satisfaction out of his fixed income.
- 2. Ordinal Utility:** Indifference curve analysis is based on the assumption of ordinal utility. It is called ordinal utility because it is expressed in the form of ordinal numbers. Ordinal numbers are those numbers which express the ranks in services, like first, second and third etc. According to this, consumer can express his preferences in ranks for different combination of goods. They are not required to express the utility of any goods in the form of cardinal numbers. A consumer expresses by comparing the utility in the form of 'more' or 'less', and not in the form of numbers 2, 4, 6, 8 etc.
- 3. Diminishing Marginal Rate of Substitution:** According to **Baumol**, "Indifference curve analysis assumes that marginal rate of substitution diminishes." It means, as the stock of a commodity increases with the consumer, he substitutes it for the other commodity at a diminishing rate.
- 4. Non-Satiety:** Consumer does not reach the level of satiety. Consumer prefers more quantity of a commodity in comparison to less quantity, i.e. 5 sweets instead of 2. If consumer prefers the more quantity of a particular commodity in comparison to less, then he must have that much amount of goods that further increase in goods' quantity will not increase the satisfaction level.
- 5. Consistency in Selection:** There is consistency in consumer's behaviour. It means that if at any given time a consumer prefers 'A' combination of goods to 'B' combination, then at another time also he will not prefer combination 'B' over combination 'A'.

$$\text{If } A > B, \text{ then } B \not> A$$

(It reads : If A is greater than ( $>$ ) B, then B cannot be greater than ( $>$ ) A).

- 6. Transitivity:** This analysis also assumes transitivity with regard to indifference and preference. It means if a consumer prefers 'A' combination to 'B' combination and 'B' combination to 'C' combination then he will definitely prefer 'A' combination to 'C' combination. Likewise, if a consumer is indifferent towards 'A' and 'B' and he is also indifferent towards 'B' and 'C', then he will also be indifferent towards 'A' and 'C'.

## 4.9 Properties of Indifference Curves

The main properties of indifferent curve are as follows:

- 1. An indifference Curve generally slopes downwards from left to right:** An indifference curve slopes downwards left to right, i.e., negative. This property of indifference curve is based on assumption that if a consumer uses more quantity of one commodity, he will use less quantity of others, then only the satisfaction from different combinations of goods will be equal.

In Fig. 4.6 IC curve shows the left to right downward sloping indifferent curve. As it is shown by IC curve, then consumer can have equal satisfaction with combination 'A' and 'B', because in case of combination 'A', if quantity of oranges is more than in combination 'B', then quantity of apples is less than in combination 'B' consequently, slope of indifferent curve is negative as like IC curve, i.e., sloping downward from left to right, convey to the point of origin.

Notes

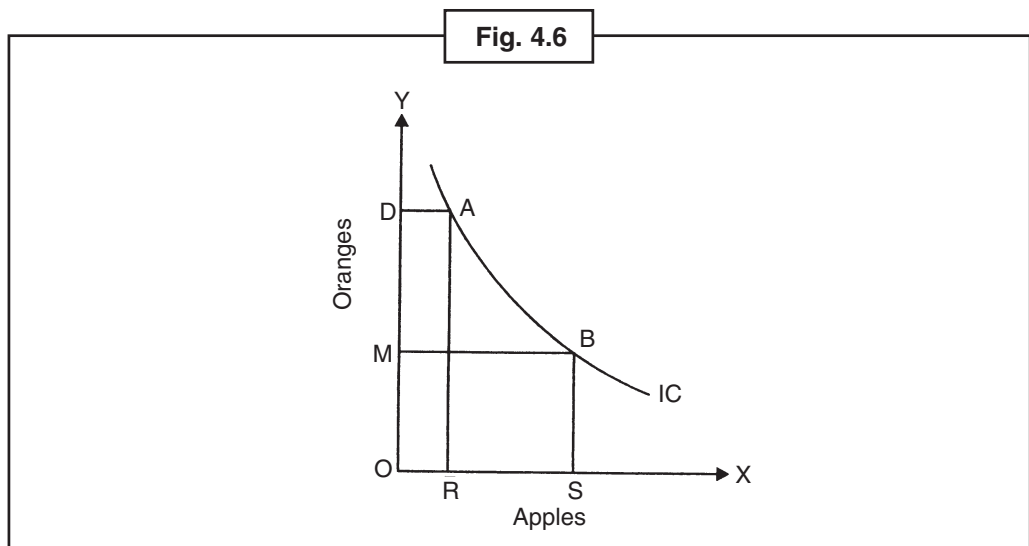

2. **Convex to the point of origin:** Indifference curve is generally convex to the point of origin (i.e., sloping downward). By convex curve it represents bowing inward to the point of origin. In other words, slope of indifferent curve goes flatter as we shift forward along with curve. Slope of indifference curve is known as rate of marginal substitution, because it presents the rate at which consumer substitutes one commodity (like apple) with the other commodity (like orange) to maintain same level of satisfaction. In other words, this property of indifference curve is based on the law of diminishing marginal rate of substitution.

The convex property of indifference curve is due to the diminishing marginal rate of substitution.

In Fig. 4.7, the indifference curve is **Convex** to the point of origin 'O'. It signifies that marginal rate of substitution of apples for oranges is diminishing. It means as the consumer gets more and more apples he will tend to give up less quantity of oranges. The consumer gives up 3 oranges (AB) for getting one additional apple, 2 oranges (CD) for getting another apple and 1 orange (EF) for getting yet another apple. This situation conforms to real life. Consequently, indifference curve is convex to the point of origin.

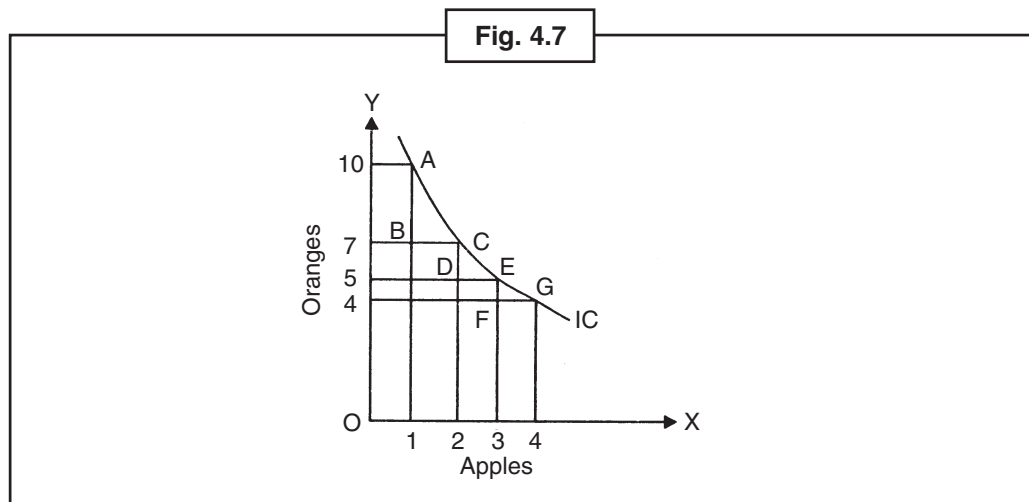

3. **Indifference curve never touch or intersect each other:** Each indifference curve represents different level of satisfaction, so they neither touch nor intersect each other. In Fig. 4.8 two indifference curves  $IC_1$  and  $IC_2$  have been shown intersecting each other at point A, but it is not possible at all. Points 'A' and 'C' on indifference curve  $IC_1$  represent combination yielding equal satisfaction, that is satisfaction from 'A' combination = satisfaction from 'C' combination. Likewise 'A' and 'B' on indifference curve  $IC_2$  represent combination yielding equal satisfaction that is satisfaction from 'A' combination = satisfaction from 'B' combination. It indicates that the satisfaction from 'B' combination is equal to satisfaction from 'C' combination, but it is not possible because in 'B' combination quantity of oranges is more than in 'C' combination, although quantity of apples in both combinations is equal.

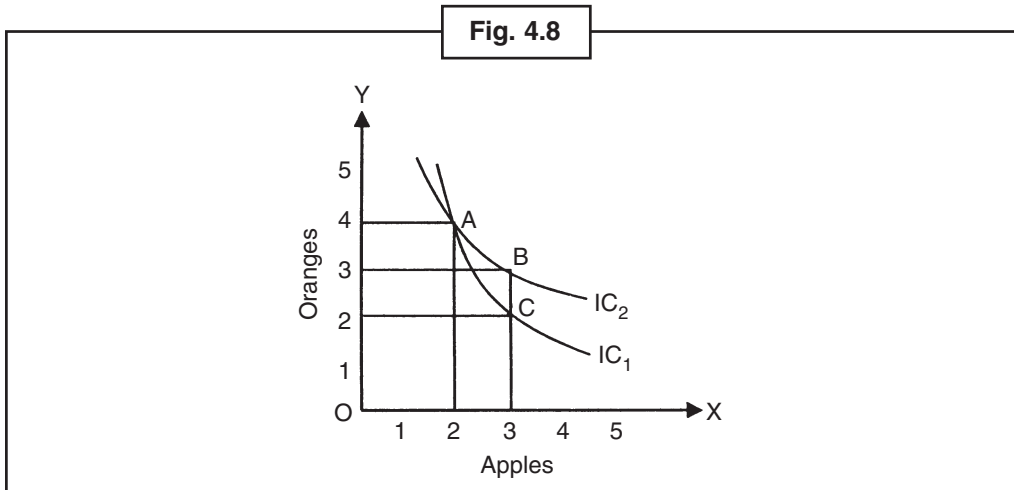

4. **Higher indifference curve indicates higher satisfaction:** It is the property of indifference curve that in indifference map, the higher indifference curve represents greater satisfaction in comparison to the lower indifference curve. This property can be clarified with the help of Fig. 4.9. In the figure  $IC_2$  represents higher and  $IC_1$  represents lower indifference curve. Point 'B' on  $IC_2$  represents more units of apples than point 'A' on  $IC_1$  curve, although the quantity of orange is same. Hence point 'B' is on  $IC_1$ . It is evident therefore, that higher the indifference curve, greater the satisfaction it will represent.

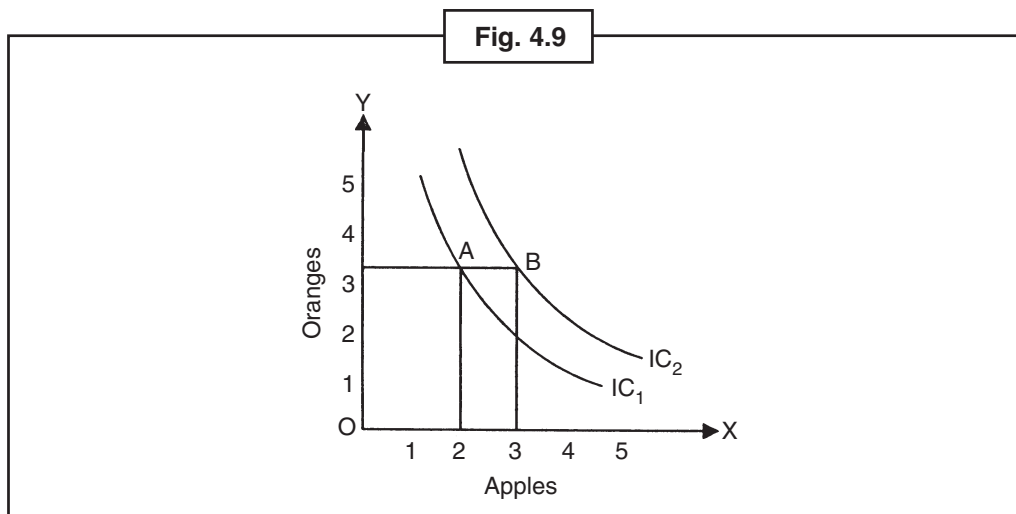



Notes

5. **Indifference curve should generally not touch X-axis or Y-axis:** It is assumed that consumer buys the combination of goods, and then indifference curve touches neither X-axis nor Y-axis. If indifference curve touches either of the axes then it means consumer wants only one commodity and his demand for the second commodity is zero. It is only possible when out of two commodities, one commodity represents money. An indifference curve may touch Y-axis if it represents money. As shown in Fig. 4.10 indifference curves IC touches OY-axis at point 'M'. It means the consumer wants to keep OM quantity of money and does not want to buy any unit of apples. In opposite at point 'N' consumer likes to have a combination of OP quantity of money and OQ quantity of apples. This combination will yield him same satisfaction as by keeping only money i.e., by OM amount of money.

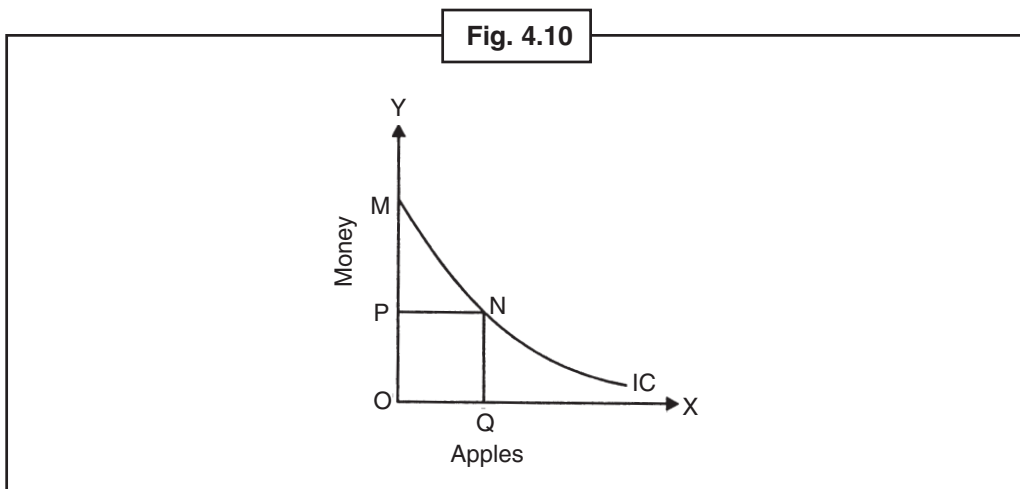

6. **Indifference curve need not be parallel to each other:** As shown in Fig. 4.11, indifference curves may or may not be parallel to each other. It depends on the marginal rate of substitution of two curves shown in the indifference map. The marginal rate of substitution of different points on two curves diminishes at constant rate, then these curves will be parallel to each other, otherwise they will not be parallel.

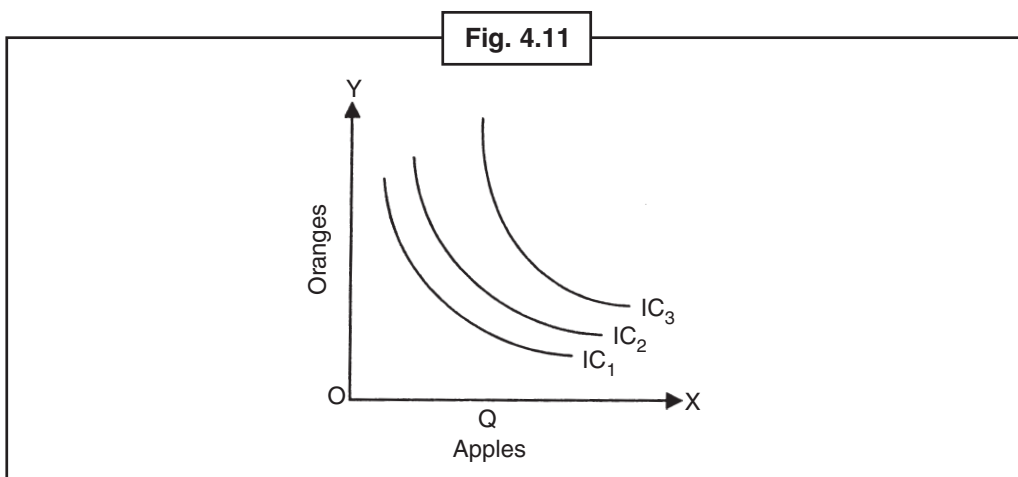

### 4.10 Some Exceptional Shapes of Indifference Curves

Following figure shows some exceptions of indifference curve.

- Exception 1: Straight Line Indifference Curve – Perfect Substitutes:** If commodity X and Y are perfect substitutes, then the marginal rate of substitution (MRS) will be 1:1. Two goods are substituted when consumer will substitute one commodity for another at constant rate. For perfect substitute goods the indifference curve is straight line as shown in Fig. 4.12. By the slope of these curves the substitution rate of two goods is clarified.

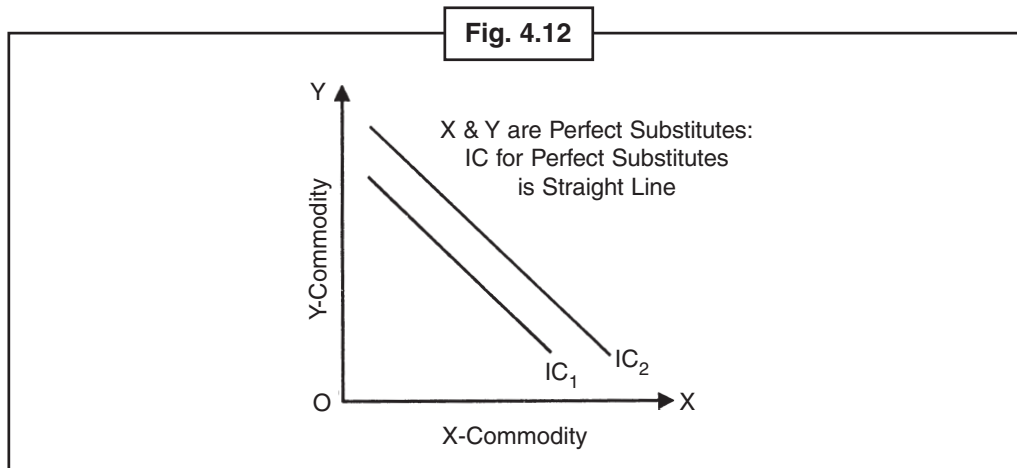

- Exception 2: L-shaped (Right Angled) Indifference curve: Perfect complements:** Indifference curve of perfect complements, as shown in Fig. 4.13 is L-shaped (Right Angle). Perfect complementary goods are those which are used simultaneously in the definite ratio for instance, right shoe and left shoe are perfect complement because one is useless without the other. When consumer has its minimum number then there is no rate at which one shoe be substituted for another.

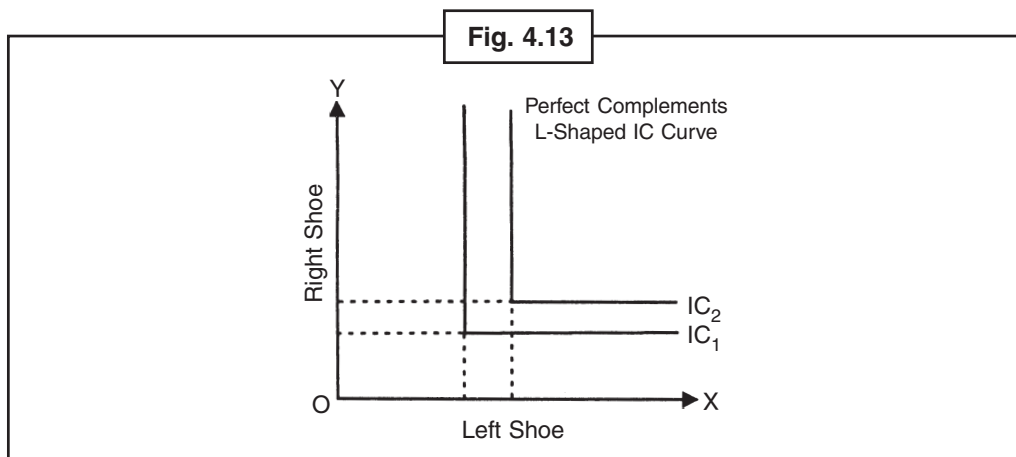

- Exception 3: Horizontal Indifference Curve – Goods that give zero satisfaction:** When any product yields zero satisfaction then the consumer will not want to sacrifice even the last quantity of the other product to get a single unit of that product. For instance, indifference curve of cigarettes for a non-smoker, as shown in Fig. 4.14, will be a straight line. Indifference curve of that product which yields zero satisfaction, will be parallel to OX (at which product yielding zero satisfaction is shown).

Notes

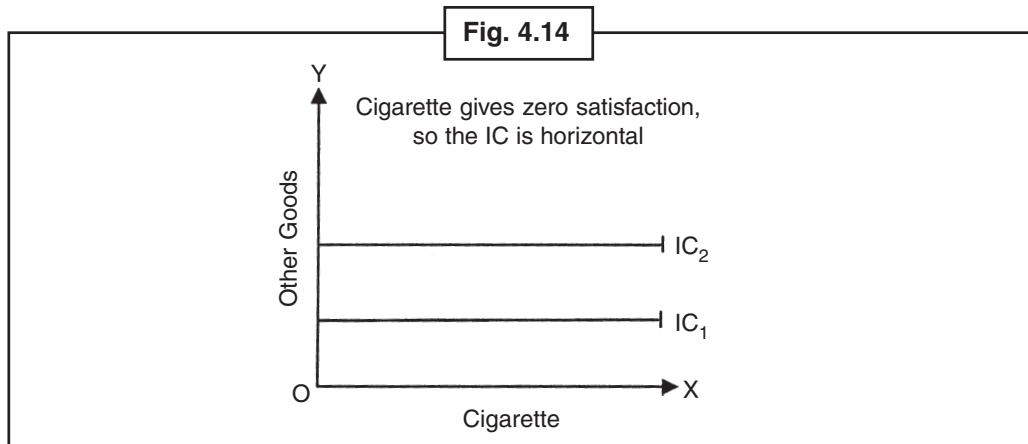

4. **Exception 4: U-Shaped Indifference Curve Goods that give Negative utility:** If consumption of any product will result in negative utility after a certain limit, then its indifference curve, as shown in Fig. 4.15, will be U shaped. For instance, at point Q, the consumer gets the quantity of goods which are needed. After point Q, slope of indifference curve becomes positive. This shows that consuming additional food will give negative utility to consumer. That's why he will be eager to sacrifice some quantity of another product to avoid utilizing that product. That is why after consuming any product till a certain limit the utility derived from it becomes negative and slope of indifference curve becomes positive.

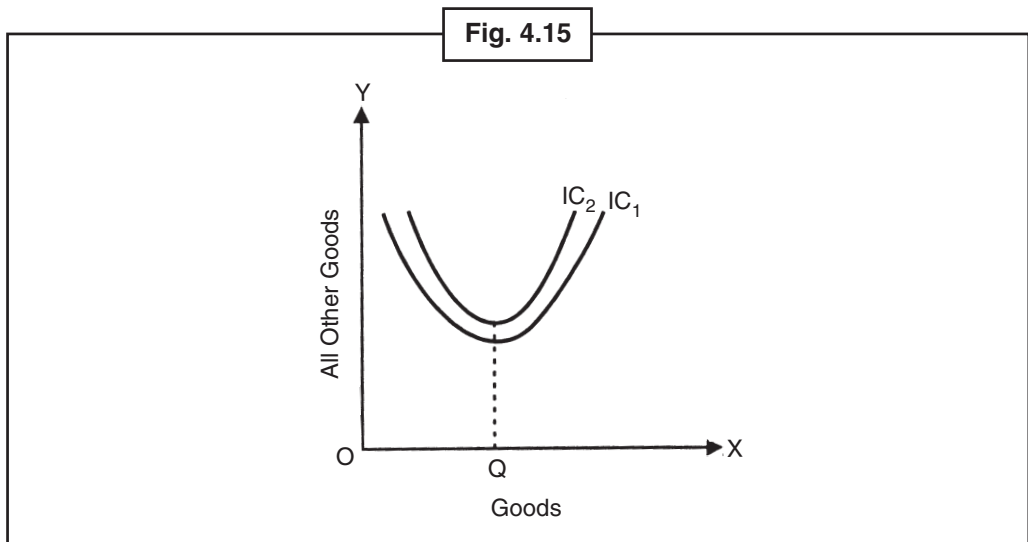

### 4.11 Budget Line or Price Line

Indifference curve itself cannot simply predict the behaviour of the consumer because it leaves two important information and those are income of the consumer and price of the product. Information about income and price is shown by a different line in indifference figure, that line is known as budget line or price line.

Study of Budget line is essential to know about consumer's equilibrium situation through indifference curve analysis. This line is also known as price line, consumption possibility curve or line of combinations.

According to Hibbdon, "The budget line is that line which shows all the different combinations of two commodities that a consumer can purchase, give his money, income and the price of two commodities."

**Explanation**

Suppose income of the consumer is ₹ 4.00, he wishes to spend all his money on apples and oranges. Price of oranges is ₹ 0.50 per orange and price of apple is ₹ 1.00 per apple. Combinations of these two commodities which the consumer can buy with his definite income and definite price of apples and oranges are shown in table 5 and Fig. 4.16.

Table 5: Alternative Consumption Possibilities			
Combination	Income (In ₹)	Apple (Price ₹ 1.00)	Orange (Price ₹ 0.50)
A	4.00	0 +	8
B	4.00	1 +	6
C	4.00	2 +	4
D	4.00	3 +	2
E	4.00	4 +	0

From table 5, we can know that if the consumer wishes to buy only oranges then he can buy maximum 8 oranges with his definite income of ₹ 4. In contrast, if the consumer wants to buy only apples then he can buy maximum 4 apples with his definite income. He can buy any combination in between these limits of apples and oranges also as 6 oranges + 1 apple, 4 oranges + 2 apples, 2 oranges + 3 apples. In Fig. 4.16 different combinations of two products are shown in line AE. This line is known as budget line or price line. As we have assumed that the consumer spends his entire income on these two products, so AE budget line or price line is limit line of the consumer slope of Budget line is the ratio of prices of the two products apples and oranges i.e.

**Slope of Budget Line** =  $\frac{P_a}{P_o}$ ; where  $P_a$  = Price of apples,  $P_o$  = Price of oranges.

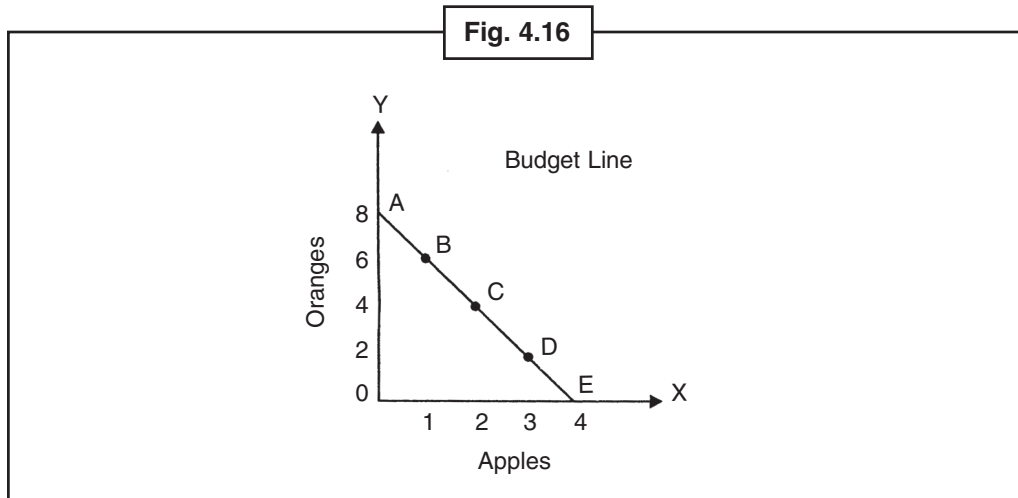

According to Lipsey, "The slope of the budget line is the negative of the ratio of two prices with the price of the goods that is placed on the horizontal OX axis appearing in the numerator."

Notes

**4.12 Properties of Budget Line**

If the prices of two commodities are fixed or constant, then budget line will contain the following properties:

1. It would be a straight and normal line.
2. Its slope will be negative.
3. Its slope will be equal to negative inverse ratio of prices of two commodities, i.e., oranges and apples =  $(-) \frac{P_a}{P_o}$ .
4. If two budget lines represent equal prices of products but different levels of income, then both lines will be parallel.

**4.13 Shifting of the Budget Line or Price Line**

The status of budget line depends upon two factors - (1) Income of consumer and (2) the price of those two products which are desired by consumers. Following could be the changes in budget line -

1. **Changes in income:** If pricing of both the products will not change then the budget line will go up if the price will go up and it will reverse if the price will change. In other words, if price of both the products is stable and the income of consumer is changed then the status of budget line is changed, but there is no change in slope. As Fig. 4.17 describes that when the income of consumer was ₹ 4.00 then he was able to buy the conjugation of apple and orange represent by line AB. If the income of consumer goes up by ₹ 5.00 and there is no change in price of apple and orange then consumer can buy more quantity of both orange and apple. Now he can buy 5 apples in spite of previous 4 and also can buy 10 oranges instead of 8. The budget line will move to the right line CD. Thus, if the income falls, then the budget line will come on EF, but the fallen will stable. In the words of **Lipsey**, "A change in household's income shifts the budget line parallel to itself, outwards when income rises and inwards when income falls."

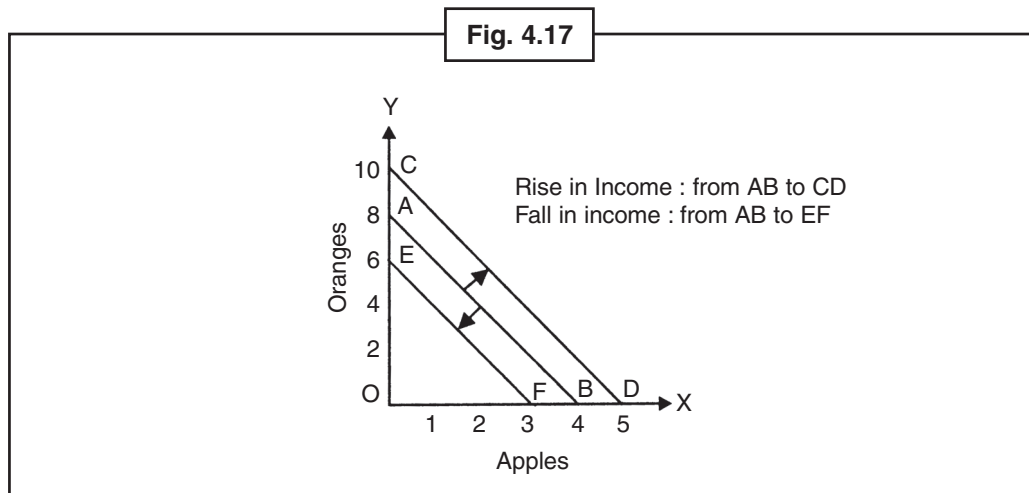

2. **A Proportionate change in all prices:** When income is stable and prices of all the products are changed then the budget line changes proportionally. If prices are up then it goes to its root point and vice versa. Thus if the average prices are dropped then there is change in the status of budget line but the slope of budget line will not change. It will up if price ups and will fall or drop if price

drops. These effects will be same as effect occurs in change of real income. Figure 4.18 represents that when the income of consumer was ₹ 4.00 and the cost of an apple was ₹ 1 per apple and cost of an orange was ₹ 0.50 then the budget line was AB. When the cost of apple and orange drops by 50% and income is stable, then budget line will move upward on CD. But if the average cost of both the products will up then the budget line will move downwards on EF.

Notes

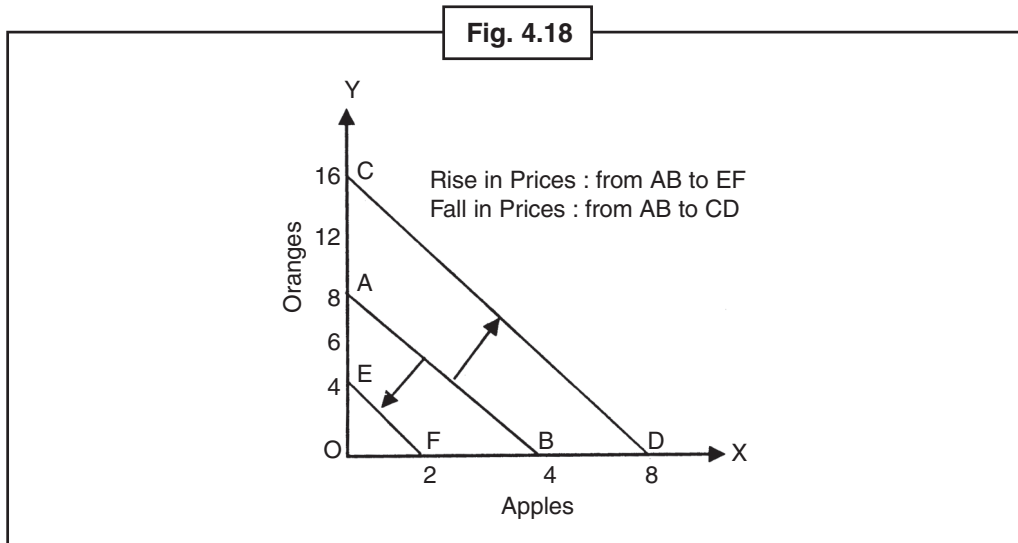

3. **Change in the price of one commodity only:** If the income of consumer and price of a product are stable, but the price of second product is changed, then the slope of budget line is also changed. This affects stable to a budget line but the point of line will change as per the second product i.e. if the product price increases then the line will move backward to its root point. But if the price decreases then it will come upward from its original point, i.e., move upward to X-axis. Figure 4.19 states that if the price of apples is decreased but the income as well as the price of orange will stable then the budget line will move from AB to AC. In this situation, consumer can buy more apples. If the price of apple increases by ₹ 2.00 then the budget line will move backward to AD and thus, consumer would buy less apples.

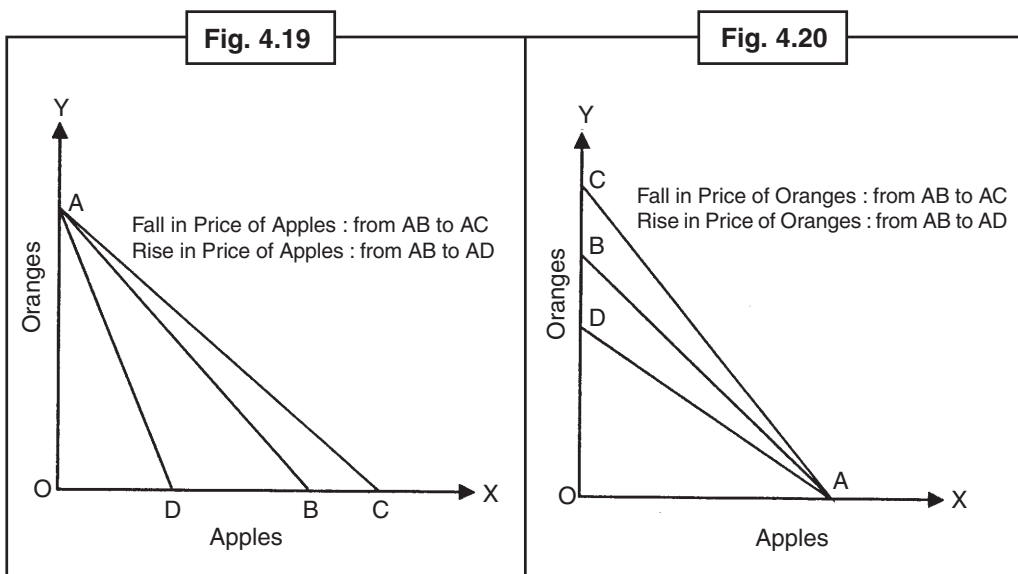

**Notes**

Now assume that the price is stable for apple but the price is changed for orange. Also assume that the income of consumer is stable by ₹ 4.00 as Fig. 4.20 shows the original budget line is AB. Budget line would be AC if the price of orange falls and it will show that consumer now can buy more oranges than his normal income. But if the price of orange changes then the budget line will go backward on AD and it will show that consumer can buy less oranges from his stable income. In summarized way, the slope of budget line has changed if the price of a product changes and all other situations remain same.

**4.14 Consumer’s Equilibrium**

Every consumer wants to buy maximum satisfaction with his fixed expenditure. A consumer can know with the help of indifference curve that how can he get maximum satisfaction with spending his income in various products. When consumer gets his maximum satisfaction with his limited income then it is called Consumer’s Equilibrium. Thus consumer equilibrium describes that the consumer wants to buy maximum satisfaction on expenditure on fixed products and services with his fixed income and not want to change this at all.

In the word of **Kautsvyani**, “The consumer is in equilibrium when he maximizes his satisfaction given his income and the market prices.”

**4.15 Two Basic Conditions of Consumer’s Equilibrium**

The consumer’s equilibrium finds where the tangency is between budget line and convex indifference curve.

As per **Kautsvyani**, “The two terms for consumer’s equilibrium are”:

- (i) Budget line or price line should be tangent to indifference curve means for X, the marginal change ratio should average to its price of Y i.e.  $MRS_{xy} = \frac{P_x}{P_y}$ .
- (ii) Indifference Curve must be Convex to the origin.
- (a) Budget line or price line should be tangent to indifference Curve: In Fig. 4.21, AB is budget or price line. IC<sub>1</sub>, IC<sub>2</sub> and IC<sub>3</sub> are indifference curves. A consumer can buy any combination

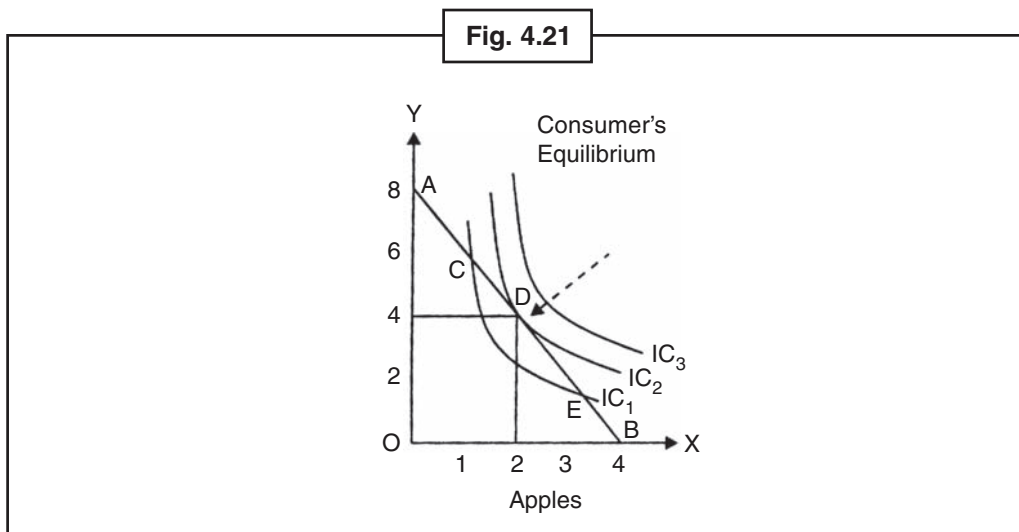

A, B, C, D and E of apples and oranges on AB price line. He cannot buy any combination on  $IC_3$  because it is far from AB price line. He can only buy those products, which are on line AB but also on above most line of indifference curve. Here this curve is  $IC_2$ . The consumer would be in equilibrium on combination D (4 oranges + 2 apples) from combination A, B, C, D and E because on this point, the budget line (AB) is the tangent line of above most indifference curve  $IC_2$ . There is no doubt that consumer can buy the combination of C or E. But this will not give him maximum satisfaction because it is in lowermost indifference curve  $IC_1$ . This means that the point of tangency of budget line and indifference curve is consumer's equilibrium point. In the words of **Watson**, "When consumer is in equilibrium, his highest attainable indifference curve is tangent to budget line." The slope of indifference curve and budget line is equal on equilibrium point D. The slope of indifference curve X is marginal substitution rate ( $MRS_{xy}$ ) for product Y and the slope of price line is the average of  $P_x$  of product X and  $P_y$  of product Y.

In equilibrium state -

$$\text{Slope of indifference curve} = \text{Slope of budget or Price Line or } MRS_{xy} = \frac{P_x}{P_y}$$

In summary, the first term of consumer equilibrium is price line should be tangent to indifference curve means the marginal moving rate for the product X to product Y and the price average of product X and Y should be equal.

- (b) **Indifference curve must be convex to the origin:** The second term for equilibrium is indifference curve should be upward to its original point. It means that marginal moving rate for the product X to product Y should be downward. If indifference curve is **Concave** and not **Convex** on equilibrium point then this is not equilibrium state. This statement is defined by **Hicks** by Fig. 4.22.

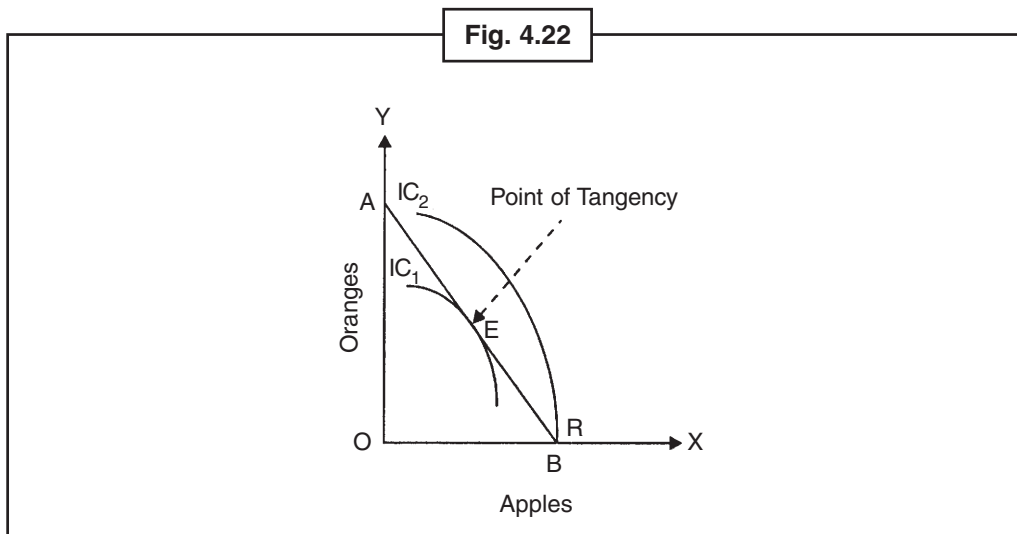

AB is the price line in Fig. 4.22.  $IC_1$  is indifference curve. Price line AB is tangent line for indifference curve  $IC_1$  to point E. So the average of cost of products and marginal moving rate are equal on point E but point E is not a fixed stable point. The marginal moving rate is increasing on this point rather than decreasing. The indifference curve is concave to the root point O on point E, so it does not follow the second rule of equilibrium. It does not mean that to move left or right from the point E, consumer will go to the uppermost indifference curve. So the equilibrium will not constant on point E. Tangent line E



**Notes**

has not defined the maximum satisfaction on given curve. Actually, the tangent point E would be the lowest satisfaction point on lowermost indifference curve, while the uppermost marginal curve would be in a point of budget line (as R point is shown on diagram). To move left or right on budget line AB, can touch the indifference curve until consumer not touches the point R on indifference curve  $IC_2$ . This point represents the status of corner equilibrium. In other words, if indifference curve is concave then the equilibrium state will be at the end which represents that only one product is used. The consumer only buys apples not oranges in the corner equilibrium point E. So the consumer will get maximum satisfaction when indifference curve touches not only the budget line but also upward on the root point.

**4.16 Effect of Change in Commodity Price on Consumer's Equilibrium**

The effect of a product price due to its demanded quantity is called Price Effect. It can be classified into two parts (i) Income Effect and (ii) Substitution Effect.

**Price Effect = Income Effect and Substitution Effect**

**4.17 Price Effect**

The price effect may be defined as the change in the consumption of goods, when the price of either of the two goods changes while the price of the other goods and the income of the consumer remain constant.

In the words of **Richards G. Lipsey**, "The price effect shows how much satisfaction of the consumer varies due to change in the consumption of two goods as the price of one changes, the price of the other and money income remains constant."

Assume that the income of consumer remains constant to ₹ 4.00 and the cost of an orange remains constant to ₹ 0.50 per unit but the price of apple changes. Thus the change of price of apple changes the equilibrium of consumer and that is called **Price Effect**. This can be described with the Fig. 4.23. Let's assume IC is original indifference curve and AB is original price line and consumer is in equilibrium

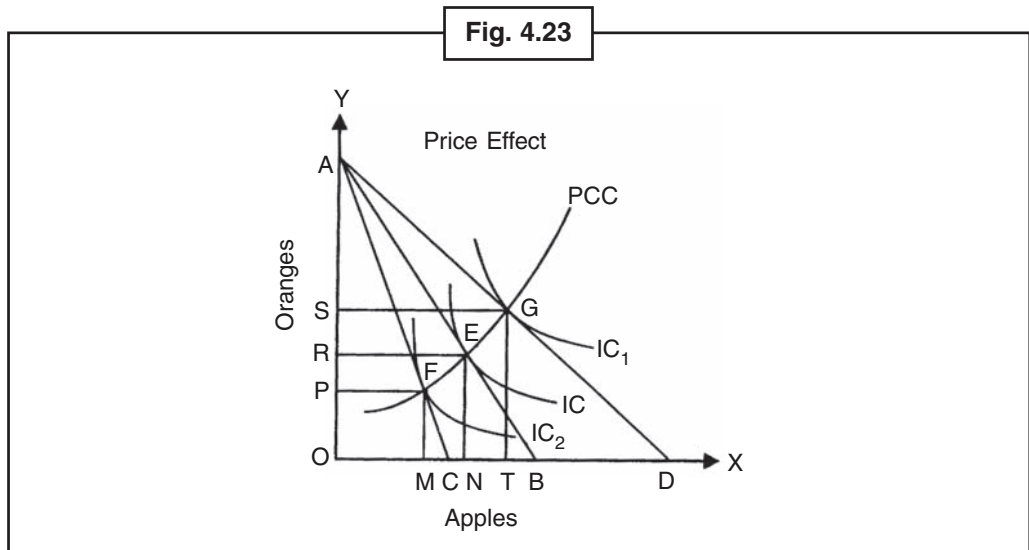

on point E. When the income of consumer and the price of oranges are stable and the price of apple downs from ₹ 1.00 to ₹ 0.50, then there is a new price line AD. This AD price line touches the uppermost indifference curve  $IC_1$  to point G. Point G is new equilibrium point. In another words, the demand of apples will increase from ON to OT, means the demand will increase by NT, which would be called **Price Effect due to Fall of Price**. On the other hand, if the price of apple increases by ₹ 2.00 per unit with another thing remains constant, then price line will go downward to AC. This indifference curve  $IC_2$  will touch new equilibrium point F. This shows that the demand of apple will decrease from ON to OM, means the demand will decrease by MN which shows the price effect due to rise in the price. After mixing the various equilibrium points E, F and G, the new curve is called **Price Consumption Curve (PCC)**. The price effect consumption curve for commodity X represents the points of the consumer's equilibrium when only the price of X varies, the price of Y and income of the consumer remain constant. In another word, Price Consumption Curve is a curve which states that what changes will affect on consumer equilibrium if the consumer income and product value do not change. There may be so many slopes of Price Consumption Curve. But the Price Consumption Curve of Giffen products are backward sloped. But this is always not essential that it looks backward sloping for lower grade products. More detail of Price Consumption Curve is given in next stage.

#### 4.18 Income Effect

The income effect is effect to change the demand of quantity of a product which starts due to the increasing of product's price and the original income of consumer. We should assume the effect of income effect from price effect that the price of product Y does not change in respect to the price of product X. In other words, the comparison price remains constant.

This assumption is that the comparison price of product X and product Y remains constant proves when two price lines are drawn in parallel because the slope of this line is equal and the slope of price line presents the comparison price of product X and Y.

#### 4.19 Substitution Effect

The meaning of substitution effect is the changes of the demand of a product, i.e, if price affects a product and it costs more or less against another product. The cheap products are always substitution for the costly products. To extract the substitution effect from the price effect, it should assume **that the real income of consumer always remains constant. If it does not do so then it would be very difficult to get effect of substitution effect from income effect.**

#### 4.20 Identification of Substitution Effect and Income Effect of Splitting Price Effect into Substitution Effect and Income Effect

The extraction of substitution effect and income effect from price effect has two approaches: (a) The Hicksian Approach and (b) The Slutsky's Approach.

#### 4.21 The Hicksian Approach

##### 1. Separation of Substitution Effect and Income Effect for Normal Goods

The general products are those products whose substitution effect is negative but income effect is positive. Actually, the **substitution effect is always positive**. It means that demand of quantity of a

**Notes**

product increases when it costs less and the demand decreases when it costs more. Positive income effect means the real income increases when the price of product decreases and it helps to increase the quantity of products. In another words, income effect is always the proof of real income and demand of quantity but it touches light of negative relation between price and demand of quantity. In other words, **positive income affect moves in the same direction as the negative substitution effect**. In summary the substitution effect and the income effect both represent the opposite relation between pricing and demand of quantity. So the slope for general products is always moving downwards.

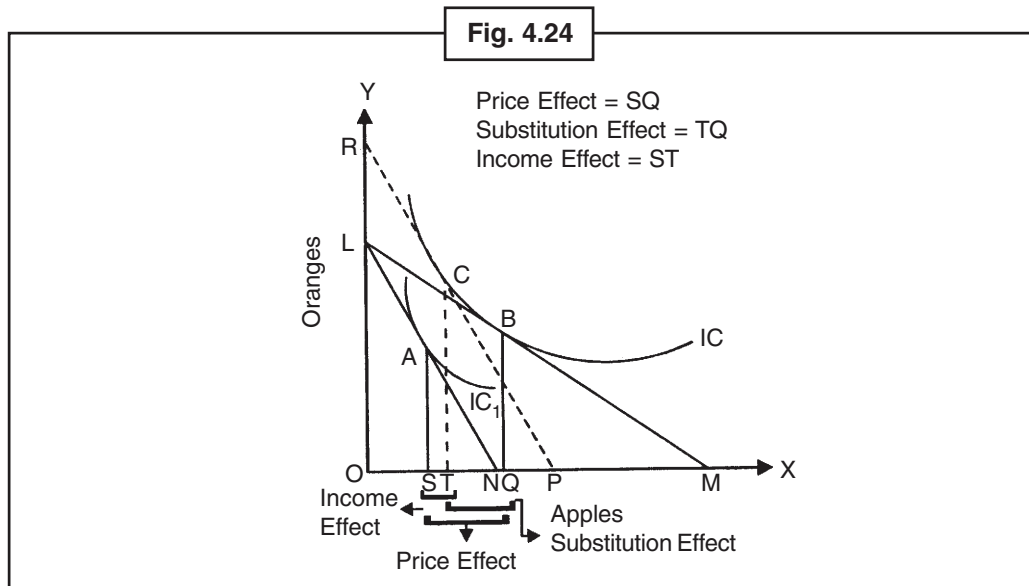

- (a) **Separation of Substitution and Income Effects for normal goods in case of Price Rise:** The division of substitution and income effect in respect of price rise for general product is defined by Fig. 4.24

Figure 4.24 represents that LM is original price line. The consumer is in equilibrium in point B of indifference curve IC. He bought the units OQ of apples. When the price of apples rises, then the price line shifts inwards on LN. The consumer gets equilibrium on point A of the indifference curve IC<sub>1</sub>. In this point, he bought the units OS of apples. The price effect shows by movement point B to A.

Or the demand of quantity from OQ to OS represents price effects. In another words, price effect = OQ - OS = SQ. The rise of price of apples represents the inclination of real income of consumer which is shown by IC<sub>1</sub>. If we increase the money income of consumer that he stood on primary indifference curve IC then new price line would be RP. This indifference curve touches IC to point C. This is parallel to price line LN which is the new pointer after increasing the demand of apples.

1. **Substitution Effect:** Substitution Effect comes by movement of Primary equilibrium point B to C. Both the points are on same indifference curve. Due to this substitution effect, the demand of apples would decrease from OQ to OT. In other words,

$$\text{Substitution Effect} = OQ - OT = TQ$$

2. **Income Effect:** Income effect comes by movement of point C to A. In another word, it would be ST.

∴ Price Effect = SQ, Substitution Effect = TQ; Income Effect = ST

So, SQ (Price Effect) = TQ (Substitution Effect) + ST (Income Effect)

- (b) **Separation of Substitution Effect and Income Effect in case of a normal goods for a price fall:** separation of Substitution Effect and Income Effect in case of a normal goods for a price fall can be described as:

The Separation of Substitution Effect and Income Effect can be represented by Fig. 4.25.

Let's assume AB is primary budget line and IC is primary indifference curve. The consumer is in equilibrium on point E. When the price of apples decreases and the income as well as the price of orange remains constant then the new budget line starts from AB to AC. The new budget line touches indifference curve  $IC_1$  to point  $E_1$  which is the new equilibrium for consumer. The movement of point E to  $E_1$  represents the price effect of apples. The consumption of apples defines the price effect difference from OT to OM and is equal to MT. The price fall of apples indicates the increase of real income of consumer. If the income of consumer decreases until he stood on primary indifference curve, or his real income remains constant, then new budget line would be PH and the new equilibrium point would be  $E_2$ .

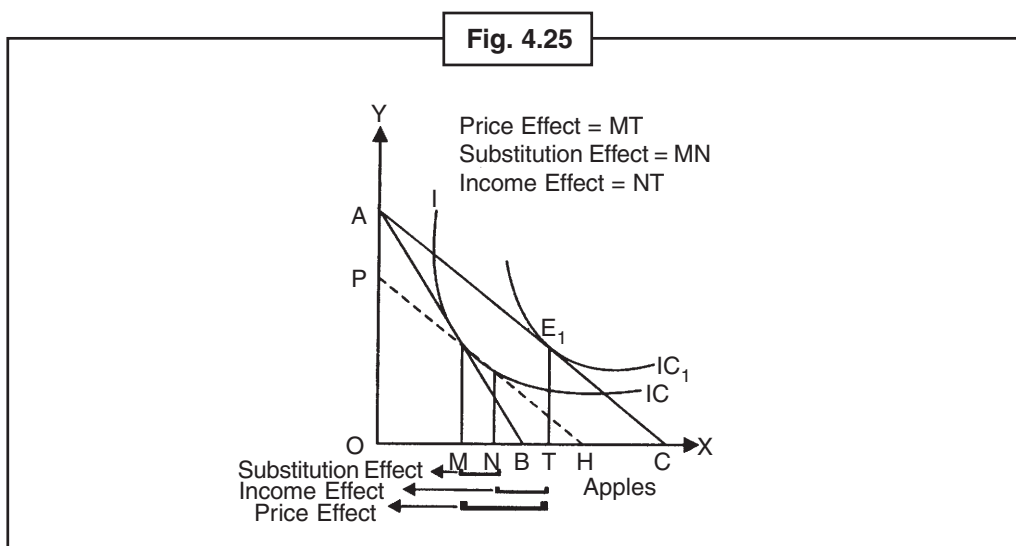

1. **Substitution Effect:** This represents the movement from initial equilibrium point E to  $E_2$  because the point is in parallel to indifference curve IC.
2. **Income Effect:** It is represented by point NT (from point  $E_1$  to point  $E_2$ ). The main reason to buy point  $E_2$  is however, the income of consumer is stable but he gives priority to lesser value of apples rather than costly oranges. The movement from equilibrium point E to new equilibrium point  $E_2$  represents the effect of the prices of oranges and apples. The effect occurs on apples as MN and this is called Substitution Effect.

In other words, the consumer bought many oranges due to its less price and this is called **Price Effect**. In the figure, consumer bought more units of apples MT. He bought MN units for substitution effect and NT units for income effect. It means the demand of apples:

*The income effect represents by the movement from one indifference curve to another indifference curve. Due to this, the effect of change in income is with having stable direct price.*

**Price effect = MT; Substitution effect = MN; Income effect = NT**

So **MT (Price Effect) = MN (Substitution Effect) = NT (Income Effect)**

In summary, due to the negative substitution effect, the change in demand is opposite to change in price. If price falls then due to substitution effect, demand of product increases. On the other hand, if price rises then due to substitution effect, demand of product decreases.

Notes

2. Separation of Substitution Effect and Income Effect for Inferior Goods

There is an inferior commodity and the income effect as well as substitution effect is negative for this commodity. The negative income effect means real income increases if the price falls and for this, the demand is less. The reason behind this is that the consumer demands less inferior goods if the income increases. So the negative income effect shows that the demand decreases if the price falls. But the negative substitution effect shows that the demand increases if the price falls. The negative substitution effect and the negative income effect work in opposite direction. So the demand increases due to negative substitution effect while the demand decreases due to positive substitution effect. **Many inferior goods have powerful negative substitution effect rather than negative income effect.** In this situation, negative substitution effect is dominant and it neutralizes the income effect. **So if the price falls, then the demand of inferior goods is more than general goods and the demand decreases if the price rises.**

(a) **Separation of substitution and Income Effect for Inferior Goods in case of Price Rise:** If price rises then how the separation shows in substitution and income effect as below:

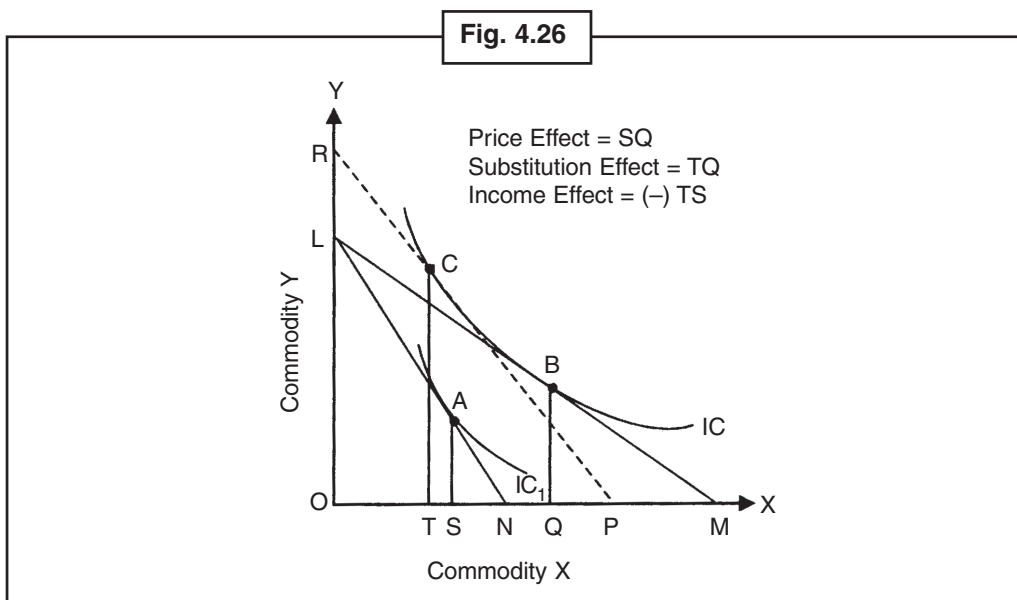

In Fig. 4.26, LM is initial budget line. The consumer is in equilibrium on point B on indifference curve IC. He bought OQ quantity of inferior product X. When the price of product X increases, then the budget line sloped backwards on LN. The consumer will be in new equilibrium state on point A on indifference curve IC<sub>1</sub>. On this point, he bought OS units of product X. The movement of point B to A represents the decrease of price effect from OQ to OS. In other words, price effect = OQ - OS = SQ. The real income would fall if the price of product X falls as shown the sloping of indifference curve from IC to IC<sub>1</sub>. If we increase the real income of consumer as he stood on initial curve IC, then the new budget line would be RP. This indifference curve touches IC to point C and parallel to line LN. The new equilibrium point would be C. Thus it means:

(i) **Substitution Effect:** The movement of initial equilibrium point B to C shows substitution effect. Both the points are in same indifference curve IC. The change of price due to substitution effect is shown by the decreasing of OQ to OT. In other words-

$$\text{Substitution Effect} = \text{OQ} - \text{OT} = \text{TQ}$$

(ii) **Income Effect:** The income effect is shown by the movement of point C to A. The income effect is negative for the inferior goods which is shown by -ST. But the negative substitution effect is

more than negative income effect. So the demand is less when price increases and the theory of demand is also implemented in inferior goods.

**Price Effect = SQ; Substitution Effect = TQ; Income Effect = -TS**

Then SQ (Price Effect) = TQ (Substitution Effect) + (-) TS (Income Effect) = SQ

- (b) **Substitution Effect and Income Effect for Inferior Goods in case of Price Fall:** The separation of substitution effect and income effect for inferior goods due to price fall can be described as follows:

**To Remember**

*The substitution effect always displays the consumption of cheap goods rather than costly goods. No matter that goods are normal or inferior. So we do not put (+) or (-) prior to substitution effect.*

In Fig. 4.27 LM is initial budget line. Consumer is in equilibrium on point B on indifference curve IC. He buys OQ quantity of inferior product X. When the price falls for product X, the budget line has sloped as LN. The consumer is in equilibrium on point A on indifference curve IC<sub>1</sub>. The price effect is shown by the movement of equilibrium point B to A or the increase of demand from OQ to OS. In other words, **Price Effect = OS - OQ = QS**.

The real income of consumer will increase if the price of product X will rise as the indifference curve shows by sloping from IC to IC<sub>1</sub>. If we stood consumer on IC by stabilizing his real income, then in this situation, the new budget line would be RP and equilibrium point would be C, where new budget line RP is touching old indifference curve IC on point C. RP is equivalent to LN which represents the new average of product price by fall of the price of product X.

**Fig. 4.27**

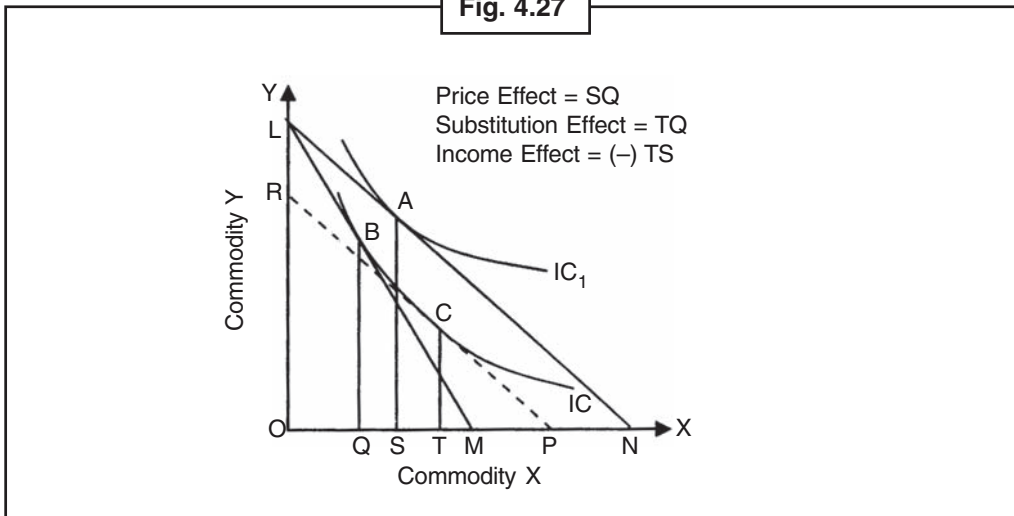

- Substitution Effect:** The substitution Effect is rising by movement of point B to C. Both the points are in same indifference curve IC. The substitution effect represents price falling and increasing of quantity of product from OQ to OT. In other words, **substitution effect = OT - OQ = QT**.
- Income Effect:** The income effect shown by movement of point C to A. Income effect is lowest in terms of inferior goods, which is shown by (-ST). But negative substitution effect is lower than

- Notes**
- negative income effect. So the demand increases if the price falls and the demand theory occurs on inferior goods too. In other words,
  - Price Effect** = OS - OQ = QS
  - Substitution Effect** = QT
  - Income Effect** = (-ST)
  - So QS (Price Effect) = QT (Subs Effect) + (-ST) Income Effect = QT - ST

### Self Assessment

State whether the following statements are True/False:

8. Every consumer wants to get maximum satisfaction with his limited income.
9. The slope of indifference curve generally occurs downward from right to left.
10. The recognition of indifference curve analysis is dropping of marginal rate.
11. The sloping of downward of indifference curve happens due to dropping of marginal rate.
12. Substitution Effect is always positive.

### 4.22 Giffen's Paradox

In the early 19th century in Britain, **Sir Francis Giffen** discovered an **exception** by studying the behaviour of labour in pricing of wheat and quantity of bread, which is called Giffen's Paradox. This paradox explains that the inferior food which is a main food item for poor and on which they spend a big part of his income (like Bread in 19th century Britain and currently corn in Rajasthan), on which (i) the Income Effect of Price Effect is positive, (ii) the positive Income Effect is more powerful than Substitution Effect and hence the theory of demand is not applied on it. These products are called Giffen's product. In other words, **Giffen products are those products which get less demand if price falls and get more demand if price rises. Thus Giffen products are those inferior products where the theory of demand is not applied means the demand is less if price is less and vice versa.**

*Giffen Paradox gives the idea where the theory of demand applies. The sloping of Giffen Products is from downward to upward. This represents that if the price falls, the demand of product is also low and there is low demand of product if price gets its maximum level.*

### 4.23 Income and Substitution Effects in Case of Giffen Goods

The substitution effect is always positive for all products like general or inferior as per **Giffen**. The meaning of positive substitution effect is if the product X gets cheaper then product X will be bought more than product Y means there is substitution for product X by product Y.

Income effect is positive for inferior goods. The positive Income Effect means the real income of consumer increases if the price falls for product, so he demands less for that product.

However, the rise of real income of consumer helps to try more to the substitution product of good quality. Since the income effect is negative for inferior product but it is not important that it is more powerful than substitution product, so the **Net Effect** or Price Effect is affected more by substitution effect. In this case, the theory of demand is applied if there is negative income effect. But in terms of **Giffen's products-**

- (a) **Income Effect is negative and**
- (b) **The negative income effect is more powerful than substitution effect. So Net Effect or Price Effect is affected by negative income effect. This means that the price of product and demand**



has positive correlation. In other words, the theory of demand is not applied on Giffen's products.

Notes

The theory of demand is not applied when negative income effect is dominating on net effect. The difference between income effect and substitution effect in terms of Giffen's product can be described as follows-

Figure 4.28 represents the income effect and substitution effect of Giffen's product.

The substitution effect for Giffen's product tells that cheap product can be bought in more quantity, but in this situation it is so negative that it fails the substitution effect. So, a product can be bought in less amount even if its price is low.

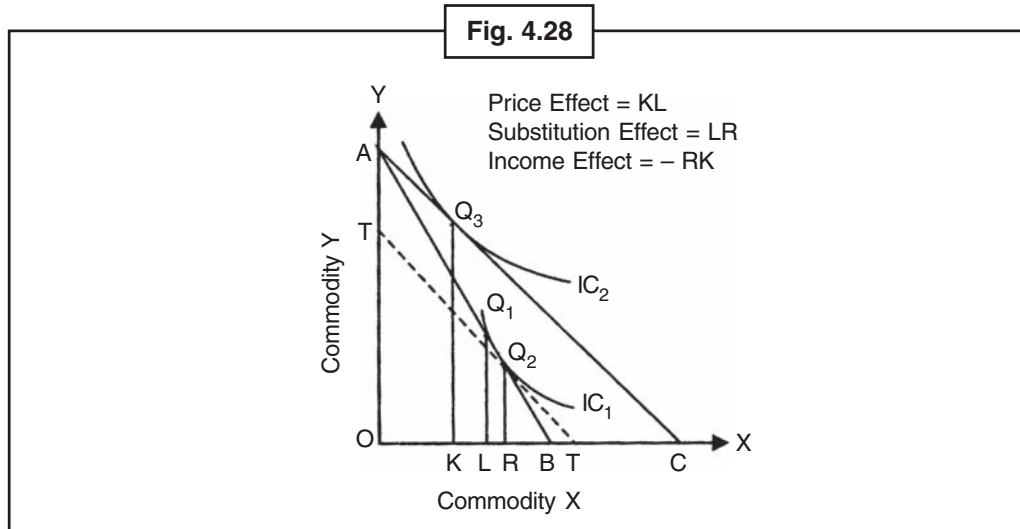

In Fig. 4.28, AB is initial budget line and IC<sub>1</sub> is initial indifference curve. The equilibrium point for consumer is Q<sub>1</sub> where he demands OL units of Giffen's product X. The budget line goes right to AC if the price falls for product and the new equilibrium point for consumer is Q<sub>3</sub>. We know that there is net effect of movement from Q<sub>1</sub> to Q<sub>3</sub>. We can get substitution effect by drawing a line TT with parallel line AC and which touches point Q<sub>2</sub> of indifference curve IC<sub>1</sub> and it is equal to LR. If price falls for product X, it is cheaper than product Y, so the consumption quantity of product X will always increase by LR. By this figure it represents that income effect is negative and it is equal to (-RK).

It is clear that  $(-RK) > (LR)$ . The difference is  $-KL$ .

**Net Effect or Income Effect = -KL**  
**Substitution Effect = LR**  
**Income Effect = (-) RK**

#### The Difference Between Inferior Product and Giffen's Product

1. **Giffen's Product**- Giffen products are those inferior products on which consumer spends more parts of his income. For it
  - (i) Income Effect is always negative. So if the real income of consumer rises then he demands less for the Giffen's products.
  - (ii) Negative income effect is more powerful than substitution effect. So the net effect or price effect is always positive. It means if the price of product X rises then it is more demandable.
  - (iii) The theory of demand is not applied on Giffen's products.



Notes

2. **Inferior Goods** – The inferior goods apart from Giffen's goods are those on which

- (i) Income Effect is negative.
- (ii) The negative income effect is less powerful than substitution effect, so the price effect is negative.
- (iii) The demand of theory applies on it.

The superior negative income effect reflects the demand of product X due to its price falls from OL to OK. This is the meaning of **Giffen's Paradox**. In summary, the price falls of Giffen product creates the substitution effect and it boosts the consumption of product but the income effect not only works on opposite direction but also more powerful than substitution effect. Due to this the price effect creates the less demand of product. In this situation the demand curve would be positive.

### 4.24 Possible Combinations of Income and Substitution Effects

Below is the summary of possible combination of income and substitution effect:

Table 6: Income and Substitution Effect in Case of Normal, Inferior and Giffen Goods			
Nature of Goods	Income Effect	Substitution Effect	Total Effect
1. Normal Goods	Positive	Negative	Theory of Demand does not apply
2. Inferior goods which are not Giffen's goods	Negative	Negative	Theory of Demand is applied because substitution effect is more powerful than negative income effect.
3. Giffen's goods	Negative	Negative	Theory of Demand does not apply because negative income effect is more powerful than substitution effect.

### 4.25 The Slutsky's Approach

Figure 4.29 represents the separation of income effect and substitution effect.

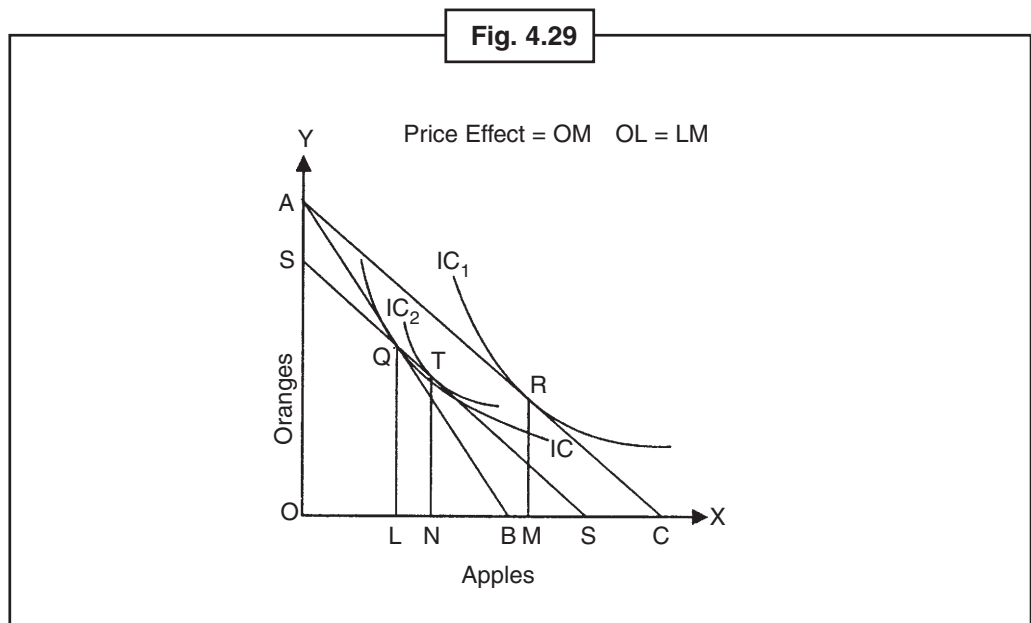

Initially, consumer is in equilibrium point Q where budget line AB and indifference curve IC touch each other. The price line slopped to AC due to the price fall of apples. Consumer now in equilibrium on point R where indifference curve  $IC_1$  and budget line AC touch each other. The movement from point Q to R represents the change of quantity from OL to OM. This is the price effect. So,

$$\text{Price Effect} = OM - OL = LM$$

**Slutsky** divides the substitution effect by taking income units to AS to untouch the real income of consumer. So the real income of consumer is unaffected on point Q. So the **new budget line SS is drawn from point Q and parallel to line AC**. The new budget line is touching indifference curve  $IC_2$  on point T which comes by lower money income and stable real income. But the real income of consumer is stable. The consumer demands ON quantity of apples on point T, while initially he was demanded for quantity OL. The substitution effect for this is (ON - OL = LN). So,

$$\text{Substitution Effect} = ON - OL = LN$$

$$\text{Income Effect} = LM - LN = NM$$

$$\text{Price Effect (LM)} = \text{Substitution Effect (LN)} + \text{Income Effect (NM)}$$

#### Some Important Points

- The negative substitution effect represents the relation of price of product and demanded quantity of product as per theory of demand.
- The negative income effect represents the positive relation of price of product and demanded quantity of product as per theory of demand.
- The theory of demand does not apply when income effect is more powerful than substitution effect and this situation occurs with Giffen's goods.

### 4.26 How Slutsky's Approach Differs from Hicks' Approach

Both **Hicks** and **Slutsky** isolate the substitution effect from price effect by neutralizing income effect. Both extract a part of money income from consumer to stabilize the real income of consumer. But there are the differences in both of the principles.

As per **Hicks**, the part of money income from consumer should retain as he gets old level of satisfaction from his income and stood on initial indifference curve. In this situation the drawn new budget line touches the initial indifference curve.

As per **Slutsky**, the part of money income from consumer should retain as consumer stood on old combination of the two goods.

In the words of **Lipsey**, "In Hicks' approach, the income effect is removed by holding satisfaction constant, while in Slutsky's approach, it is removed by holding purchasing power constant."

Figure 4.30 represents the differences between **Slutsky's** and **Hicks' view**. The consumer slopped from point Q to point R if the price of apples falls. **Price Effect = LM**.

- Hicks** draws a new budget line HH parallel to line AC. This touches the indifference curve IC to point T. Hence the **substitution effect** would equal to LK on equilibrium point T.
- Slutsky** draws a new budget line SS parallel to line AC which crosses to Q and Q is old equilibrium point of consumer.

**HH: Hicks** it touches the new budget line IC to point T. The substitution effect is LK.

**SS: Hicks** the new budget line of **Slutsky** crosses the initial equilibrium point Q. Hence, the substitution effect is equal to LN on equilibrium point E.

It must be aware that the budget line SS drawn by **Slutsky** is upward and right-side from the **Hicks'** budget line HH. This proves that as per **Slutsky**, the consumer is in equilibrium on point E where  $IC_2$  curve is touching the budget line SS.

Notes

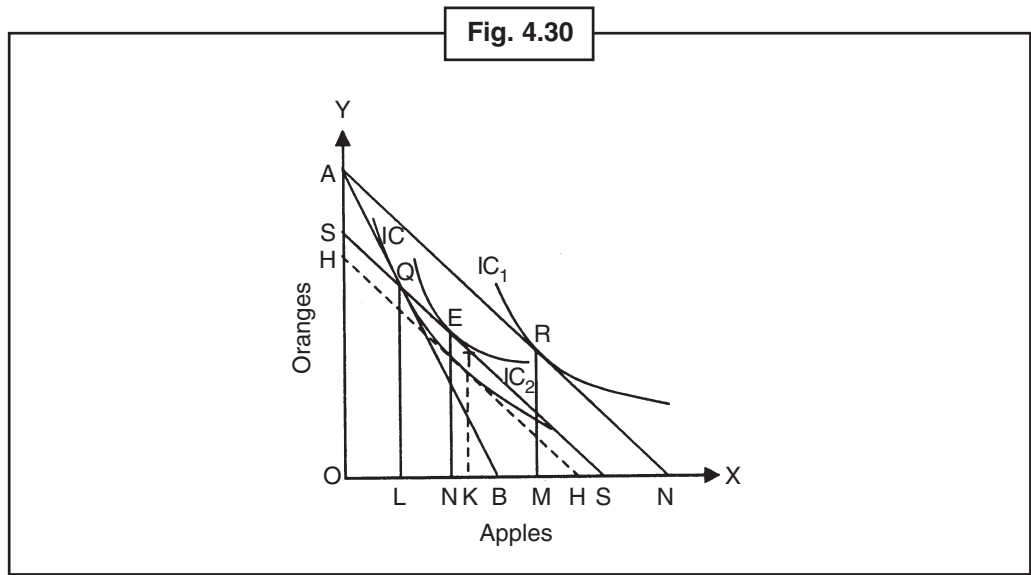

### 4.27 Price Consumption Curve

If other units are remaining same, the effect of changes in price while consumer is stable is described by **Price Consumption Curve (PCC)**. PCC is the curve which represents the combination of product X and product Y and which consumer will buy the product Y if the income and the price of product X are stable.

In the words of **Ferguson and Maurice**, "The price consumption curve is a locus of equilibrium points relating the quantity of X purchased in relation to its price, money income and all other prices remaining constant."

### 4.28 Explanation

The Price Consumption Curve can be described with the help of Fig. 4.31. In this figure apples are on axis OX while oranges are on axis OY. The budget line MQ shows that the income of consumer for

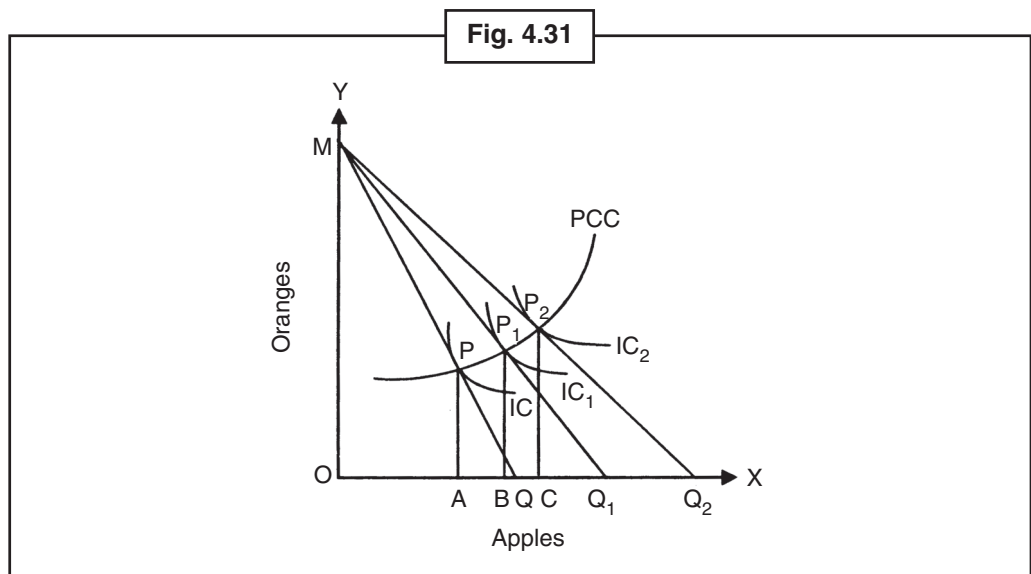

oranges is OM and for apples is OQ. Consumer is in equilibrium on point P where budget line MQ is touching the indifference curve IC. It means that consumer will buy the quantity of apple OA. Let's assume that the price of apple falls. Hence the budget line will go rightward as compared to price falls and it will now  $MQ_1$  as compared to MQ. This will touch the new indifference curve  $IC_1$  to point  $P_1$ . So the new equilibrium point would be  $P_1$ . Consumer will now buy OC quantity of apple. The combination of P,  $P_1$  and  $P_2$  is called **Price Consumption Curve**. This curve represents the effect of change in behaviour of consumer if the price of apple changes. The Price Consumption Curve is the curve which gives figure about the quantity of apples or product buys by consumer if the income and the price of other products remain stable.

### 4.29 Slope of PCC Curve

PCC generally is in right-side downwards as shown in Fig. 4.32 that as the price of product X falls, the consumption increases. The sloping of PCC curve to right-side shows the increase of demand of product X. While the upper movement of this shows the demand of product X along with product Y. The upward movement depends on how a consumer will distribute his real income to product X and Y if the price of product X falls. But in some circumstances, PCC can go backward as shown in Fig. 4.33. This represents the decline of the demand of product X if price falls. It is clear that in this situation, this product X is Giffen's product or goods.

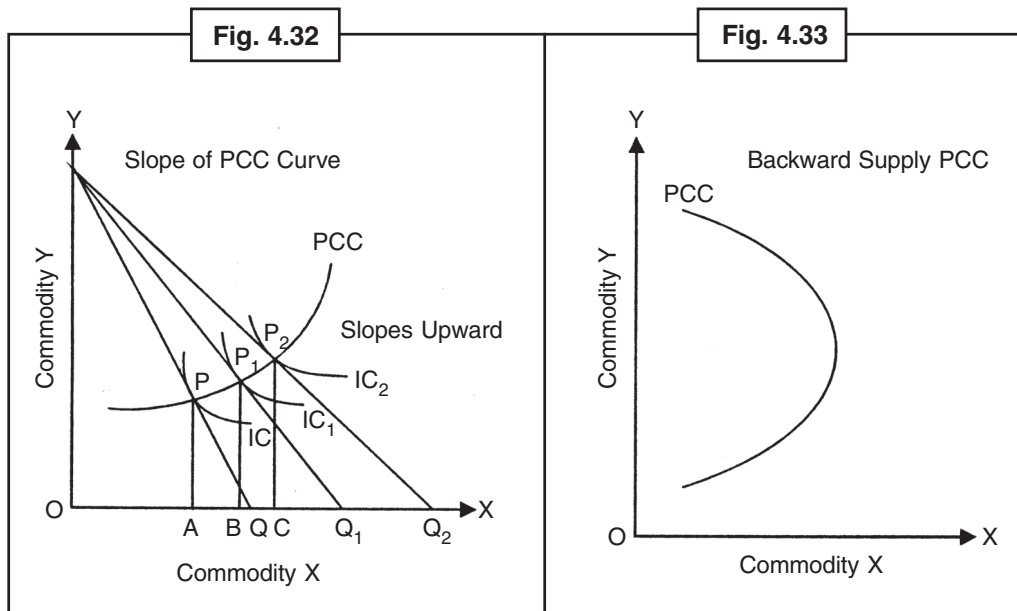

### 4.30 Derivation of Demand Curve Through Indifference Curve Analysis or Through Price Consumption Curve

The demand curve which represents the theory of demand states that there is mismatch between the quantity of product and price of product if all circumstances remain stable. If price falls then the demand rises and vice versa. In indifference curve analysis, the price consumption curve is shown by the demand curve or theory of demand. Price Consumption Curve presents the quantity of product X on every price. Thus this curve represents the initial base for creating the consumption curve of consumer.

**Notes**

In the word of Lipsey, "Every point on the Price Consumption Curve corresponds to both the price of the commodity and quantity demanded." The demand curve can be known by broadcast. Figure 4.34 represents the process of derivation.

In Fig. 4.34 (A), the quantity of apple is on axis OX and quantity of orange is on axis OY.

In Fig. 4.34 (B), the quantity of apple is on axis OX and the price of apple is on axis OY.

Let's assume that the price of orange is ₹ 1.00 per unit and the price of apple is ₹ 2.00 per unit and let's assume that the income of consumer is ₹ 10.00 and all income spend on both apple and orange. **The primary budget line is AB and indifference curve is IC<sub>1</sub> on the given consumer income and the cost of apples and oranges.** The equilibrium state of consumer is E where budget line AB touches the indifference curve IC<sub>1</sub>. This means that on the price of ₹ 2.00 per unit of apple, consumer is ready to buy 3 units. If the price of apple falls by ₹ 1.00 and the price of oranges and the income are stable, then the budget line will slopped from AB to AC. This new budget line AC will touch new indifference curve IC<sub>2</sub> on point E<sub>1</sub>. From point E<sub>1</sub> we can study that when the cost of apple is ₹ 1.00 then consumer demands for 7 apples in equilibrium state. By mixing E and E<sub>1</sub>, we can get PCC, by which we can get the demand curve for apples.

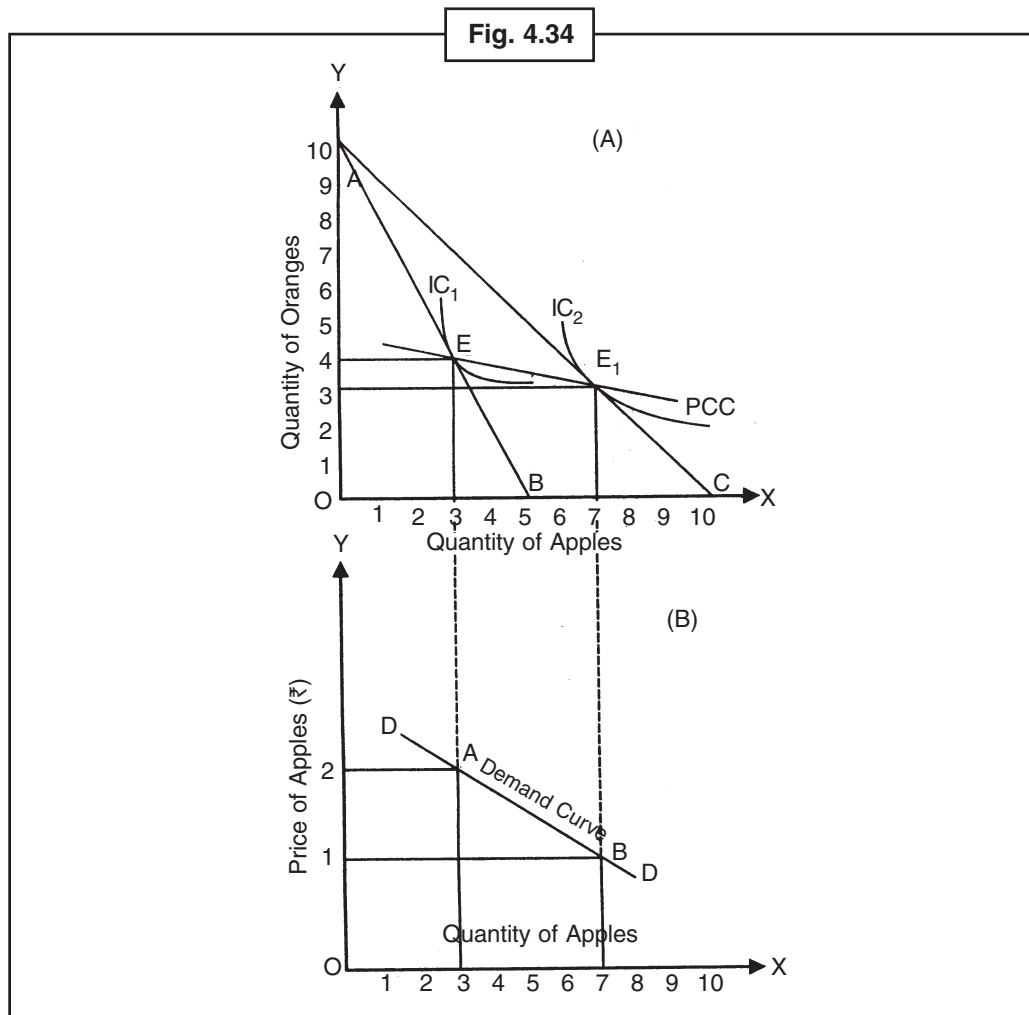

The demand of apples on point E and  $E_1$  of this price consumption curve is shown below in table 7.

Notes

Price in ₹	Demand of Apples
2	3
1	7

In Fig. 4.34 (B), the demand curve is drawn by above data. In other words, by exchanging the relation of price-quantity from Panel (A) which is shown by point E and  $E_1$  to Panel (B), we get the points A and B and if we add these points then we get the downward curve DD. This proves the anti-relation between price and demand and proves the theory of demand.

### 4.31 Difference between Demand Curve and Price Consumption Curve

However, we get similar information from Demand Curve and PCC but there are some differences of the graphs of these curves:

1. Generally, while making conventional demand curve, we put quantity of product on axis OX and price on axis OY. But while making PCC we take different products on both axes or represent a product's quantity on axis OX and unit of price or income of consumer on axis OY.
2. For general conventional demand curve, income assumed as fixed and the price of product is shown on axis OY. But in PCC we do not display price but the slope of **price line represents the price**. The image related to demand curve gives idea about the price of product and demanded quantity while by PCC we can't get the picture of relation between price of product and demanded product. **To get clarity, the conventional Demand Curve is better than PCC.**
3. By using conventional demand curve we cannot separate income effect and substitution effect onto price effect while we can clarify both by using PCC. Thus PCC is superior than conventional demand curve.

### 4.32 Income Consumption Curve

As shown in given figure, the changes in income are shown by Income Consumption Curve. **The Income Consumption Curve is that curve which represents the equilibrium quantities of goods X and Y that would be purchased at various levels of income while prices remain constant.** In short, Income Consumption Curve represents the changes in income by equilibrium of consumer.

In the words of Ferguson, "The Income Consumption Curve is the curve which shows the points of equilibrium resulting from the various levels of money income and constant prices."

#### Explanation

The Income Consumption Curve can be described by Fig. 4.35. In this figure apples are on axis OX while oranges are on axis OY. The income of consumer is OA in terms of oranges while in terms of apples it is OB. AB represents the budget line. The consumer is in equilibrium on point E where the indifference

**Notes**

curve IC touches the budget line AB. When the income of consumer rises then the budget line goes on CD and the equilibrium point also changes from E to  $E_1$ . Now at new equilibrium point  $E_1$ , the budget line CD and indifference curve  $IC_1$  touch each other. If income again rises then the budget line goes from CD to LM. And new indifference curve now is  $IC_2$ .  $E_2$  is new contact point of  $IC_2$  and LM and it is new equilibrium point too. E,  $E_1$  and  $E_2$  are the points which conjugate the Income Consumption Curve line and create Income Consumption Curve. This curve presents the quantities of apples and oranges on the various income levels.

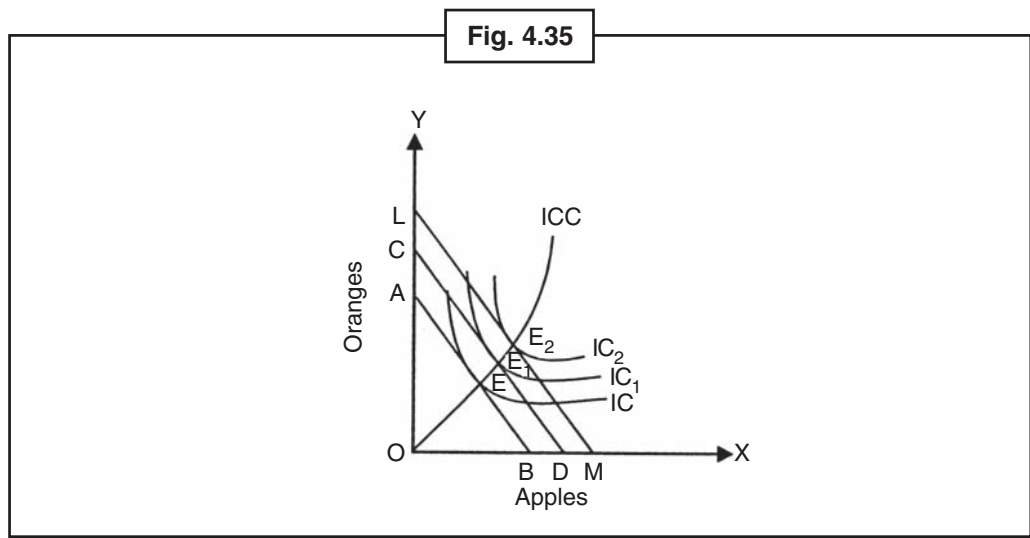

### 4.33 Slope of the Curve

The slope of the Income Consumption Curve is positive for general products and negative for inferior products. Both the slopes of Income Consumption Curve are represented by the figures.

- 1. Positive Slope or Income Consumption Curve in Case of Normal Goods:** The Income Consumption Curve is positive for the general products. In other words, if income raises then the consumption of both the products (X and Y) increases and vice versa. In Fig. 4.36, the initial equilibrium point is E on budget line AB. When this income increases then the equilibrium points would move right-side to  $E_1$  on budget line CD. If income decreases then equilibrium point will move left-side to  $E_2$  on budget line EF. The locus of all these equilibrium points is called **Income Consumption Curve (ICC)**. In other words, the curve which comes by conjugating all equilibrium points E,  $E_1$  and  $E_2$  is Income Consumption Curve. This curve starts from original point O. It means when the income of consumer is zero then the consumption of apples and oranges is also zero. Figure 4.36 shows that the sloping of Income Consumption Curve is from left to right for the normal goods. It means the consumption would be increased if income increases. The state of Income Consumption Curve depends upon the average expenditure of product X or Y.

The average expenditure of both the products would increase simultaneously and it is shown in Fig. 4.37. From  $ICC_1$ , we can know that the average expenditure would be high for product X and thus we can know from  $ICC_2$  curve that the average expenditure would be high for product Y.

Notes

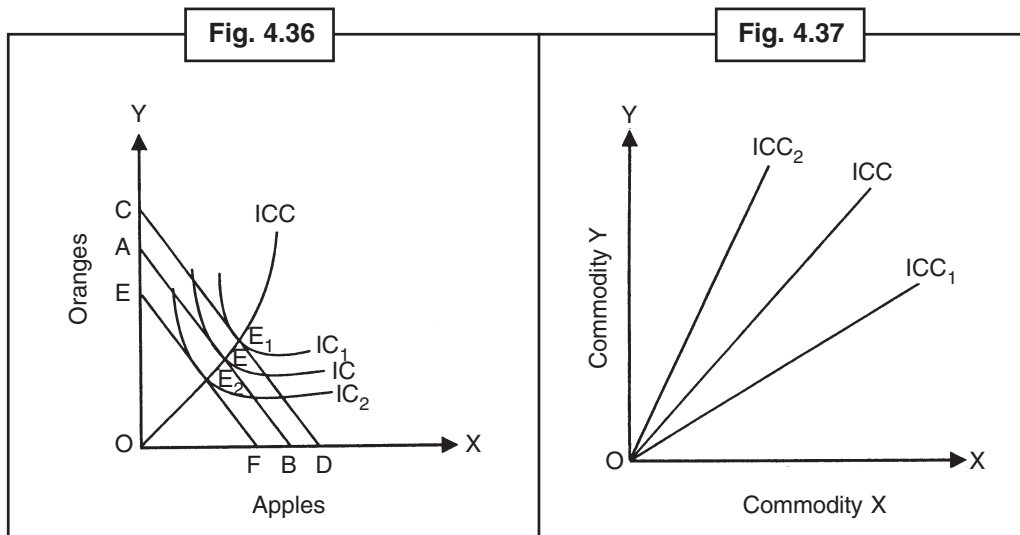

2. **Negative slope of Income Consumption Curve in case of Inferior Goods:** The inferior goods are those which are in less demand when the income of consumer rises and vice versa. The income effect is negative for the inferior products. It means if the income of consumer increases then he buys less the inferior products.



*Notes* Income Consumption Curve is the curve which represents the equilibrium points on various income levels and stable price.

Figure 4.38 represents the income effect of inferior goods. Let's assume that product X represents inferior goods and product Y represents general goods. The indifference curve IC touches the point E on the base of budget line AB which draws on given income of consumer and the price of both the products. So the consumer is in equilibrium on this point. As soon as the income of consumer increases, this budget line

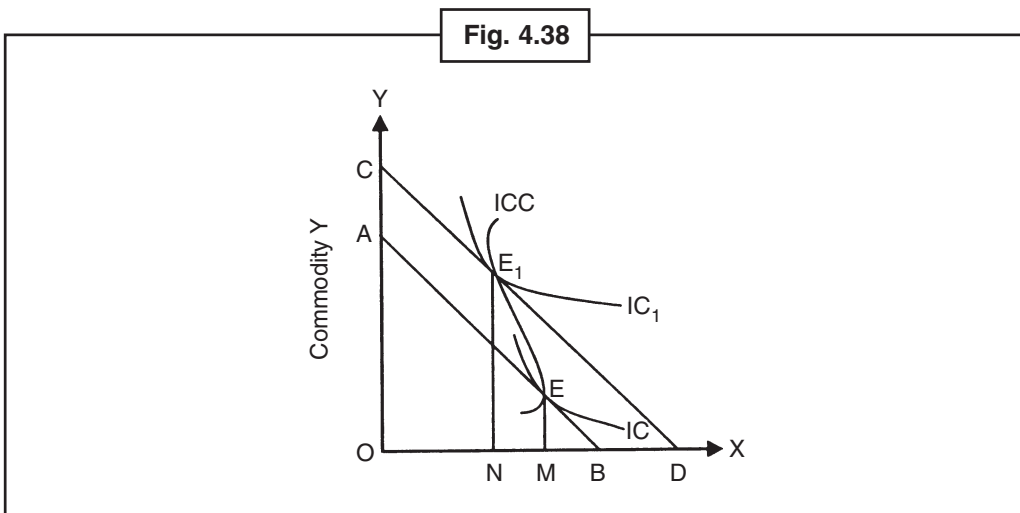



**Notes**

scroll to the right above the budget line CD is  $IC_1$  on the  $E_1$  curve touches the point. The two budget lines are parallel which show the equal value of both the products. The demand of inferior product X drops from OM to ON as the income of consumer increases. Thus the demand of inferior products is lessened by the increase in income of consumer. The Income Consumption Curve which creates by meeting the various equilibrium points E and  $E_1$  is backwards sloping to the left. This represents the negative income effect.

This is known by the  $ICC_1$  of Fig. 4.39 that product X is an inferior product. This curve is folded backward to point B which represents the lower amount of product X will buy if income of consumer increases. The curve  $ICC_2$  shows that product Y is an inferior product. This curve is folded downward to point A which means the lower amount of product Y will buy if income of consumer increases.



*Did u know?* The budget line is the line which represents the various combinations of two products.

**4.34 Engel's Curve**

The Income Consumption Curve can be used to identify the relation between the **optimum** quantity of every product and income level. The German economist of 19th century **Ernest Engel** was the first person to clarify this by the help of a curve. So this curve is called **Engel's Curve**. **An Engel Curve is a curve which shows optimum quantity of a commodity purchased at different levels of income.** Engel's Curve is not equal to Income Consumption Curve. Income Consumption Curve represents the combination of various products on various levels of income, while the prices are stable. **While Engel's Curve indicates how much quantity of a commodity a consumer will consume at different levels of his income in order to be in equilibrium.** This curve is important to study the family expenditure and applied studies of economic welfare. Engel's Curve can be drawn by Income Consumption Curve.

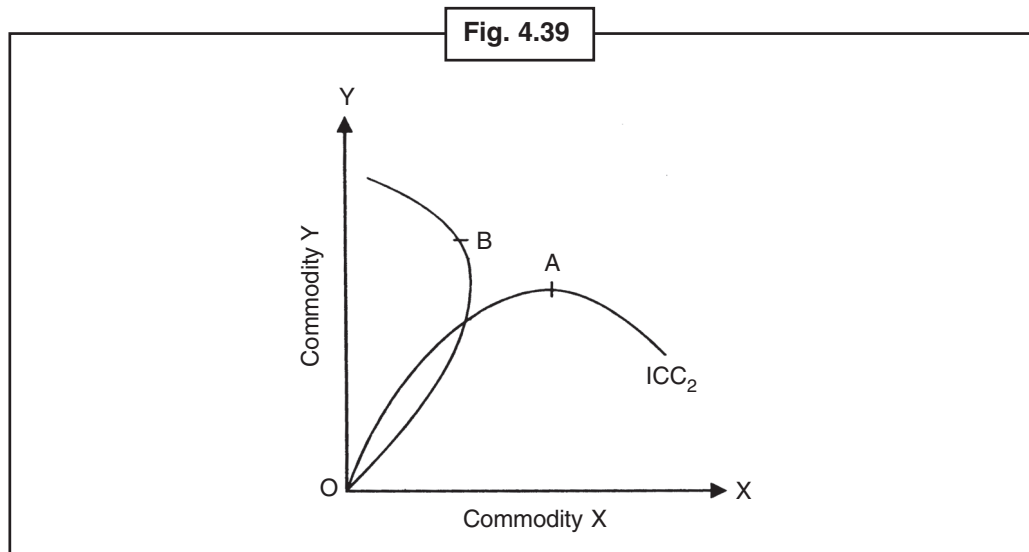

**What is the Difference between Engel's Curve, Income and Consumption Curve?**

*Income Consumption Curve represents the changes of consumption of product X and Y if the income of consumer rises. But Engel's curve represents the relation of consumption of quantity of a unique product and income of consumer.*

Notes

In Fig. 4.40 (A), apples are shown on axis OX while oranges are on axis OY. In Fig. 4.40 (B), apples are shown on axis OX while income is on axis OY. Let's assume that the cost of apple is ₹ 1 per unit and the cost of orange is ₹ 0.50 per unit. When the income of consumer is ₹ 4.00 then he buys 3 apples and 2 oranges in ICC point E. When income rises by ₹ 6.00, he buys 4 units of apples and 4 units of oranges as indicate by point E<sub>1</sub> on Income Consumption Curve. And he buys 5 units of apples and 6 units of oranges if his income increases by ₹ 8.00 and this also indicates by point E<sub>2</sub> on Income Consumption Curve. All these levels of income are shown on Fig. 4.40 (B) by drawing 3 lines on axis OX.

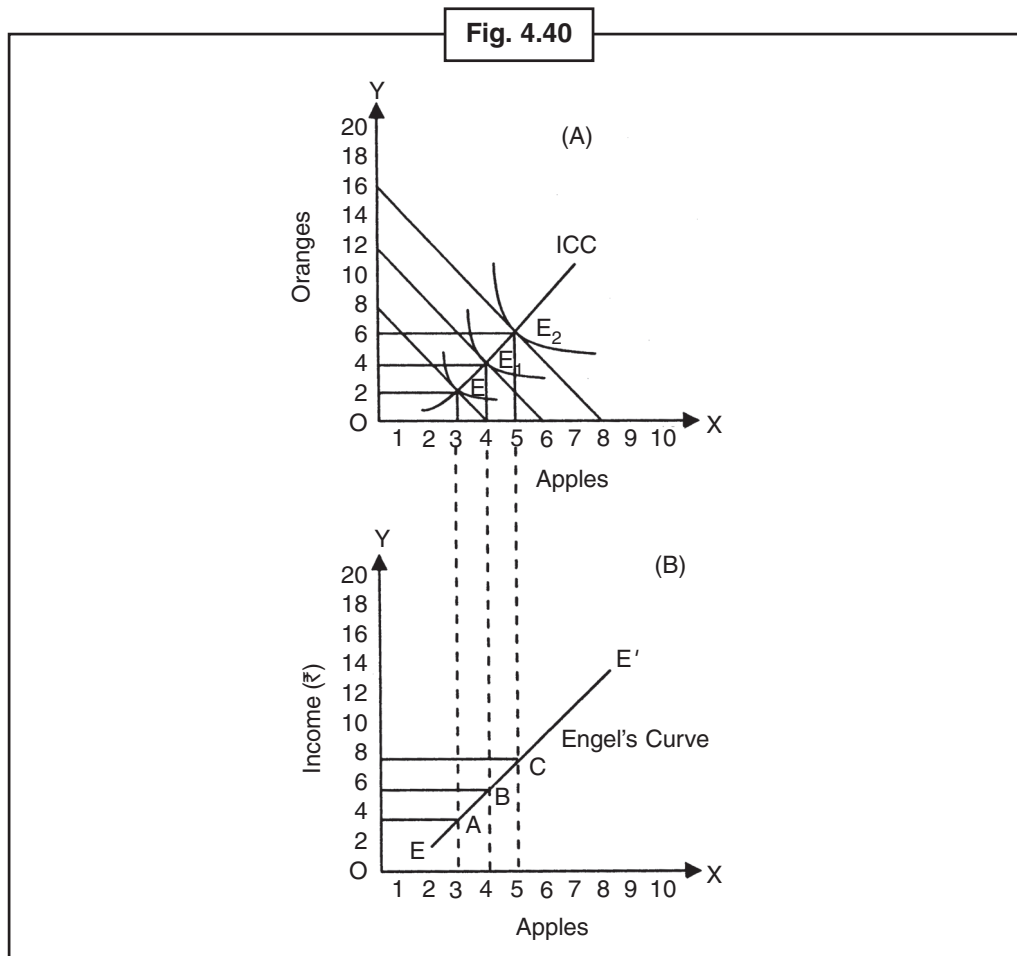

Point A indicates that on ₹ 4.00 income, consumer buys 3 apples. He buys 4 apples on point B if his income is ₹ 6.00 and if income is ₹ 8.00, he buys 5 apples on point C. By mixing the point A, B and C we get EC curve and this is Engel's Curve which represents the equilibrium quantity of apples on various price income.

**4.35 Criticism of Demand Theory**

Some economists criticize the demand theory as unrealistic by giving some exceptions. This section primarily describes the alleged exceptions of demand theory and later gives details of observations which tell the demand theory unrealistic.

## Notes



Task Give your views on Income Consumption Curve.

### 4.36 Alleged Exceptions to the Law of Demand

Mostly, the curve of demand is negatively sloped which means that the price of a product and the demanded quantity have opposite relation. But the economist states the exceptions of this term. It means some situations where demand is positive if prices are changed. Thus the demand curve occurs positively sloped i.e. its sloping is upward which indicates the positive relation between price and demanded quantity. Some observations are:

1. **Articles of Distinctions or Veblen Goods:** Veblen goods (whose name is tagged with American Economist **T. Veblen**) are honorary products like diamonds, jewellery, the paintings of big artists etc. As per **Veblen**, these honorary products are demandable when the price of these products is high. Diamond and jewellery are known as honorary products in society. The demand is high even the price is high. If the price is low then it does not call honorary products and the demand gets low. In the words of **Watson**, "If the consumer measures the desirability of a commodity entirely by its price, and if nothing influences consumers, then they will buy less of the commodity at a low price and more at a high price."

But the criticism should be done carefully for these observations. Because in any point of time, there must be some consumers who will buy these snob goods like diamond when the price will drop. While the current customer demands when price lessens. In this situation, if the number of marginal consumer is high, then the demand for diamond could increase and the total buy from them can increase from the initial buyers. This can also possible that the initial buyers always want to buy if price falls. Sometimes the shopkeeper creates pseudo falling of price by discounted products and this helps to increase the demand.

2. **Ignorance:** Sometimes consumer does not follow the lower pricing product due to the ignorance and buys the minimum quantity and if the price rises then he think that product as the best and purchases its maximum quantity. **Benhem** has given an interesting example for this that a book was published in First World War with the price of 10.5 Sh. But it didn't attract the consumers. This book was republished after the war and this time the cost was 3.5 Pound. This time, book was the best seller. Consumer thought the book quality was superior due to its price hike and thus, the book was the best seller book.
3. **Giffen Goods-** Giffen goods (name is tagged with 19th century Economist **Robert Giffen**) are those goods whose demand become less if the price falls. Thus, the theory of demand does not apply on it. For example, corn is inferior good for a normal consumer. The real income of consumer rises as the price of corn falls. He would buy wheat with his increased real income and thus the demand of corn would become low. So the demand gets low for inferior goods if the cost is less and vice versa. It must be understood that those products on which the demand of theory do not apply are Giffen's products. But is it also not necessary that the demand of theory is applicable to all inferior goods.

#### Be Careful

*All inferior goods are not Giffen's goods. The Giffen products are those products whose negative income effect is greater than substitution effect.*

### 4.37 Demand Theory is Unrealistic: Consumer Behaviour Contradictory to Demand Theory

There is some observation:

1. **All consumers do not behave in the same way:** Yes, this is correct that all consumers do not behave in a similar manner all the time. Two situations are mainly observed in this category -

- (a) Some consumers think from their heart rather than from their pocket.

Notes

A mother checks quality of the shoes only by its price while buying shoes for her child. The high price means high quality and so high demand. Does this sentiment match with the theory of demand which represents the opposite relation between price and demand of quantity? Answer is 'definitely not'.

But this behaviour is an exception and not a term. Some mothers also behave as their sentiments, while some mothers think before buying a product from her mind and so buys more quantity of product on lesser price. So for a product the sloping of demand curve can be upward, but for most of the consumer it would be negative. If the sentimental consumer buys some percentage of market products, the demand curve would be downward or negative; however, this is positive for some sentimental consumer.

- (b) Sometime all customers can buy more quantity of product on its high price for showing their erratic or unstable behaviour. Sometimes the demand of theory does not match with the behaviour of customers. But it should not be judged directly that the theory of demand is unsuccessful. This type of unstable behaviour is cancelled for these erratic consumers by those customers who are normal behaviour customers.

2. **Demand and Taste Changes:** Taste is not a quantitative variable. The effect of this on a product's demand is impossible. We can only assume this. But the guessing sticks a question mark over theory of demand. This also sticks question mark on that rule which describes the relation between price and quantity of demand.

### Illustration

See this situation in Fig. 4.41. This figure represents an assumption that the income of customer and other prices (or the price of related goods) are stable. Fig. 4.41 produces two possibilities:

**Possibility 1:** The demanded quantity is positively linked with price, so the movement of point 'a' to point 'b' on demand curve 'd<sub>3</sub>' is like Giffen's goods or subjects.

**Possibility 2:** The taste of customer changes if the price of product increases. So the point 'a' has changed on point 'b' due to the movement of demand curve d<sub>1</sub> to d<sub>2</sub>. This is the situation or example of normal goods.

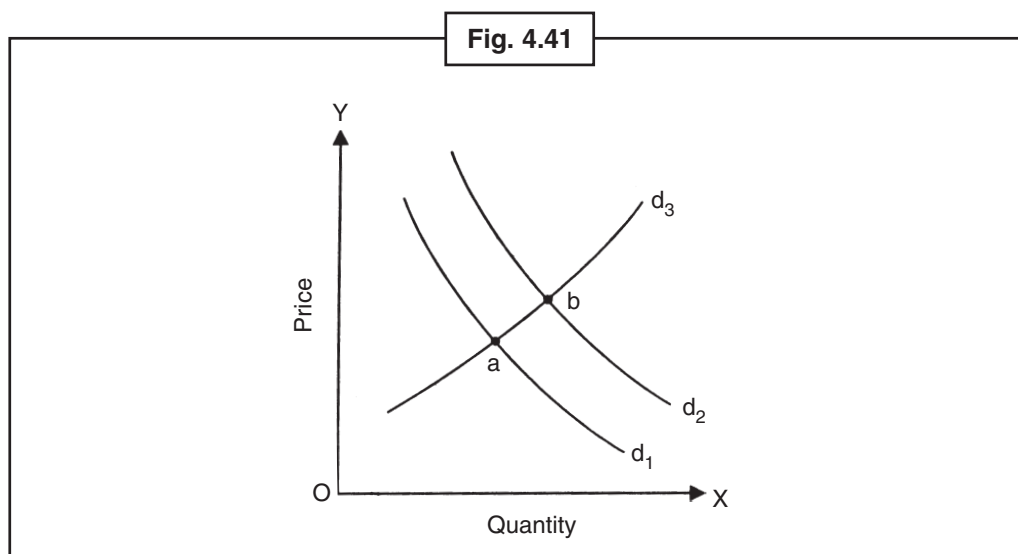

**Notes** Which possibility has happened is really hard to describe till we observe the full observation about the behaviour of consumer.

### 4.38 Summary

- General goods are those which substitution effect is negative but income effect is positive. In fact, the substitution effect is always negative. It means the demand of product increases if the cost of product lessens and the demand is less when it costs more. The meaning of positive income effect is the increasing of real income by falling of product pricing and thus the demand increases. In other words, income effect always represents the relation between real income and demanded quantity but hints the negativity relation between pricing and demanded quantity.

### 4.39 Keywords

- **Indifference Schedule:** Indifference Column
- **Marginal Substitution:** Stability of slope
- **Income Effect:** The changes in income

### 4.40 Review Questions

1. What is indifference curve? Describe it.
2. What do you mean by Marginal Substitution Rate?
3. What is the budget line? Explain it.
4. Explain the Price Consumption Curve.

### **Answers: Self Assessment**

- |             |                 |           |           |
|-------------|-----------------|-----------|-----------|
| 1. Movement | 2. Indifference | 3. Income | 4. (b)    |
| 5. (b)      | 6. (a)          | 7. (d)    | 8. True   |
| 9. False    | 10. True        | 11. True  | 12. False |

### 4.41 Further Readings



Books

1. **Microeconomics** – David Basenco and Ronald Brutigame, Wiley India, 2011, PBK, 4th Edition.
2. **Microeconomics** – Shipra Mukhopadhyay, Annie Books, 2011.
3. **Microeconomics: An advanced treatise** – S.P.S. Chauhan, PHI Learning.

## Unit-5: The Revealed Preference Theory of Demand

### CONTENTS

Objectives

Introduction

- 5.1 Choice Reveals Preference
- 5.2 The Law of Demand
- 5.3 Derivation of the Demand Curve from Revealed Preference
- 5.4 Derivation of Indifference Curve from Revealed Preference
- 5.5 Superiority of Revealed Preference Theory
- 5.6 Defects of the Revealed Preference Theory
- 5.7 Summary
- 5.8 Keywords
- 5.9 Review Questions
- 5.10 Further Readings

### Objectives

After studying this unit, students will be able to:

- Know the Law of Demand.
- Understand the Derivation of the Demand Curve from Revealed Preference.
- Know the Superiority of Revealed Preference Theory.
- Know the Defects of the Revealed Preference Theory.

### Introduction

The derivation of demand curve from **Prof. Samuelson** is theoretical numerological analysis which is **introspective to the numerological analysis** of **Hicks** and **Allen**. It is the third root of the logical theory of demand. **Hicks** states, "Direct consistency test under strong ordering." This theory analyzes the behaviour of consumer for a combination of two products in market behaviour.

### 5.1 Choice Reveals Preference

The derivation of demand theory of **Prof. Samuelson** is based on imagination which tells that choice reveals preference.

**Notes**

Under this theory, a consumer will buy a combination of two products because either he likes this rather than other combinations or it is cheaper than others. Suppose that a consumer buys combination A rather than B, C or D combination. This is because he reveals preferences towards A. This can be done due to two reasons. First that the combination of A is cheaper than combinations of B, C or D; or the consumer really likes combination A from other combinations even it is costlier than others. In this situation, it can be said that A has revealed preferences than B, C and D or B, C and D are revealed inferior than A.

Figure 5.1 indicates that X and Y both are the price of products and on given income of consumer, LM is the price line of consumer. Triangle OLM is the choice region of consumer which gives the various combinations of X and Y on his given income LM. Means consumer can choose the combinations of A and B or below this line, the combination of C and D on the line LM of triangle OLM. If he choose combination A than he reveals his preferences than combination B. The combination of C and D is inferior than A because it is below his price income line but the combination E is more costly for consumer because it is above his price income line LM. So the combination A is revealed preferred.

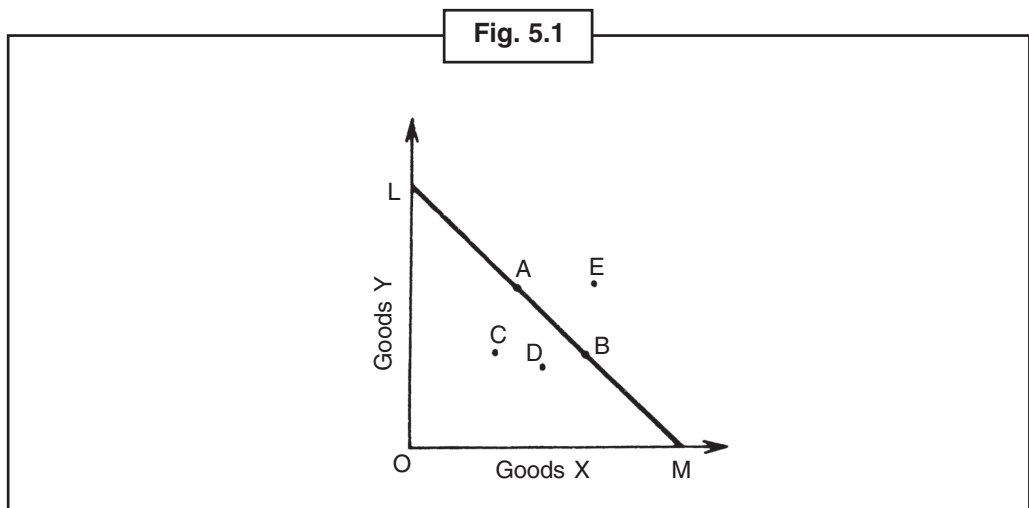

According to **Hicks**, when a consumer reveals his preference for a valid combination as per market behaviour, then he do this as a strong ordering when this situation is shown on OLM triangle in all preference situations. So when consumer represents his valid preference for combination A on triangle OLM then he refuses all the combinations like B, C and D. So the selection of A is strong ordered.

## 5.2 The Law of Demand

**Prof. Samuelson** established his law of demand directly from his imagination theory without the use of any curves or barrier of recognition.

### Its Assumptions

The law of demand of Samuelson is based on these assumptions:

1. The taste of consumer does not change.

2. The selection of a combination reveals the preference of that combination for the consumer.
3. The consumer selects a combination on a given price income line means there must be change in price whatever he buys.
4. He always gives preference for the combination of more items rather than the combination of fewer items.
5. The selection of consumer is based on strong ordering.
6. This works on consistency behaviour of consumer. If in a situation he gives preference to A rather than B, then he cannot give preference to A on B in another situation. According to **Hicks**, this is two-term consistency for which a rule must be followed on a simple line curve- (a) If A is situated on the left side of B then B must be on the right side of A, (b) If A is situated on the right side of B then B must be on the left side of B.
7. This law is based on transitivity. The transitivity directs three terms consistency. If he reveals preference for A rather than B and B over C, then consumer would must reveal preference for A rather than C. If consumer wants to select on the given possible combinations then it must be workable for the theory of choice of preference.
8. The demand of income elasticity is positive means if the income increases then the demand of produce increases and vice versa.

## Self Assessment

### Fill in the blanks:

1. The derivation of demand curve from Prof. Samuelson is theoretical ..... analysis.
2. The derivation of demand theory of Prof. Samuelson is based on .....
3. The tastes of consumer ..... change.

## Fundamental Theorem or Demand Theorem

With these assumptions, **Samuelson** has given the **Fundamental Theorem** which is also called demand theorem and as per his words, “**The demand of product (general or combined) is increased when price income increases, the demand will sure low when the price ups for this product.**” It means that when the demand of income elasticity is positive then the demand of price elasticity would be negative. This can be shown by ups and downs in price of a product.

### (a) Rise in Price

First, we would analyze the rise in price of a product X.

To prove this theorem we separate this into two stages. In the **first** stage, we would take a consumer who spends his all income in two products X and Y. In Fig. 5.2, LM is his original price income line where he selects the combination of R. Triangle OLM is the region of selection for consumer where he gets various combinations of X and Y on price income line LM. Consumer gives preference by selecting R on or in triangle OLM.



Notes

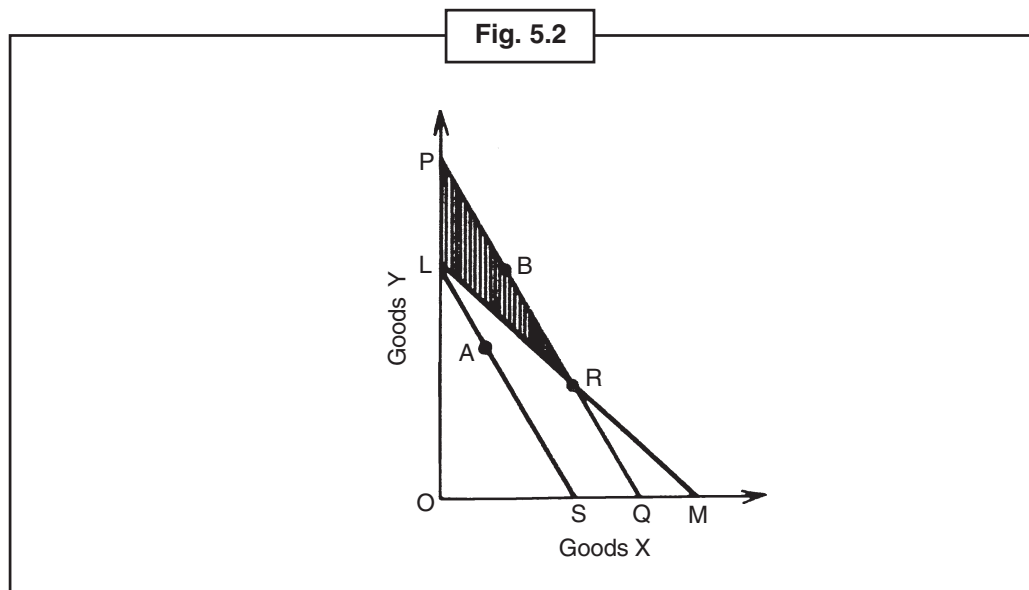

Suppose that the price of X increases by keeping the price of Y, constant and then LS would be his new price income line. Now suppose that he selects a new combination A which indicates that due to the price rise of X, the consumer will buy less of product X. The real income of consumer is down by increasing the price of product X, so LP is given to him in the form of product Y. Thus PQ is now his new price income line which is parallel to LS and crosses from point R. **Samuelson** tells this **Overcompensation Effect**. Now the selection region for consumer is triangle OPQ. Because R was preferable choice from all the points on original price income line LM, so none of the points will match with the behaviour of consumer on RQ of PQ line below to point R. So he cannot take more quantity of X if the price of X ups. So the consumer will choose R or B on the shaded region LRP on price income line PQ of PR. If he selects the combination R then he would buy the quantity of X and Y before the price hike of X. On other hand, if he selects the combination B then he would buy more quantity of Y than X.

In **second stage**, if the LP packet is taken away from the consumer then he would be in the left side of R on point A on LS line where he would buy lesser quantity of X, if the income elasticity of demand is positive because the demand is less for X due to price rise (when consumer is on point A) and hence it proves that when income elasticity is positive then price elasticity is negative.

**(b) Fall in Price**

The theory of demand can be proved when the fall of price happens with product X. This can be described in these words as, “**Any product (general or combined) whose demand decreases only when income is low, must be high on demand when only its price gets low.**” This is described in Fig. 5.3. LM is the original price income line where consumer gives preferences on point R. His price line goes to LS if the price of product X gets low but price of product Y is stable. Suppose that in this point, consumer reveals preference for combination A, which indicates that he buys more quantity of product X. The movement from point R to A has price effect due to price fall of product X and X demands high now.

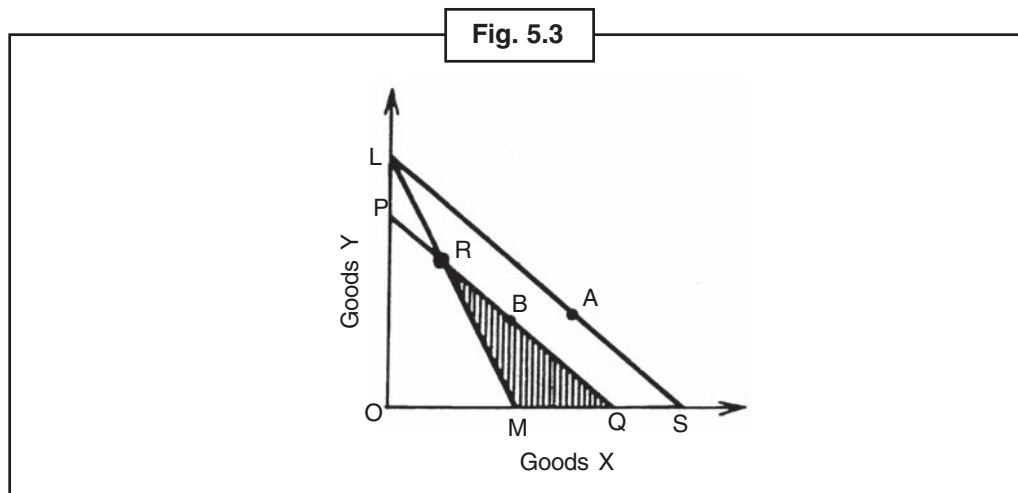

Suppose that the quantity LP of Y has been taken off from consumer which is due to increment in his real income and price of X has fallen. Now PQ is his new price line which is parallel to LS and crosses to point R. New triangle OPQ is his selection region. Since consumer was showing his desire on point R of line LM, so all the points of line RP of PQ will not match with his selection. This is because he will get the less quantity of product X on line RP, but it is not possible if price of X declines. So the consumer will reject all the combinations of above R. He would select B or R on line RQ on PQ of shaded region MRP. If he selects the combination R then he would buy the same quantity of X and Y which he was about to buy before price hike of X. And if he selects the combination B then he would buy more quantity of X than Y. There is the movement effect in pricing of X from point R to B.

If the LP has return to the consumer then he would be in A on line LS after price fall, where he would buy less quantity of X because of price fall. The movement of consumer to point B to A is income effect. Thus the theory of demand again proved that positive income elasticity means negative price elasticity of demand.

This must be underlined that the movement effect of **Samuelson** is different from indifference curve analysis. In indifference curve analysis, the consumer moves from a point to another on the same curve and his real income is stable. But in reveal preference theory this indifference curve does not happen and the movement effect is the movement of price income line by changing of real price.



**Notes** The demand of product (general or combined) is increased when price income increases, the demand will sure low when the price ups for this product.

### 5.3 Derivation of the Demand Curve from Revealed Preference

The demand curve can be derived by the imagination of revealed preference. It is shown in Fig. 5.4. In panel (A), price is in vertical axis while product X is in parallel axis. LM is the original price income line where consumer reveals his preference on point R and buys the quantity OA of product X. Suppose that the price of X falls. As a result, his new price income line is LS. On this line the consumer reveals his preference on point T and buys more OB quantity of product X. The movement from point R to T is Price Effect for price falls of X and so its **demand increased** from OA to OB.

Notes

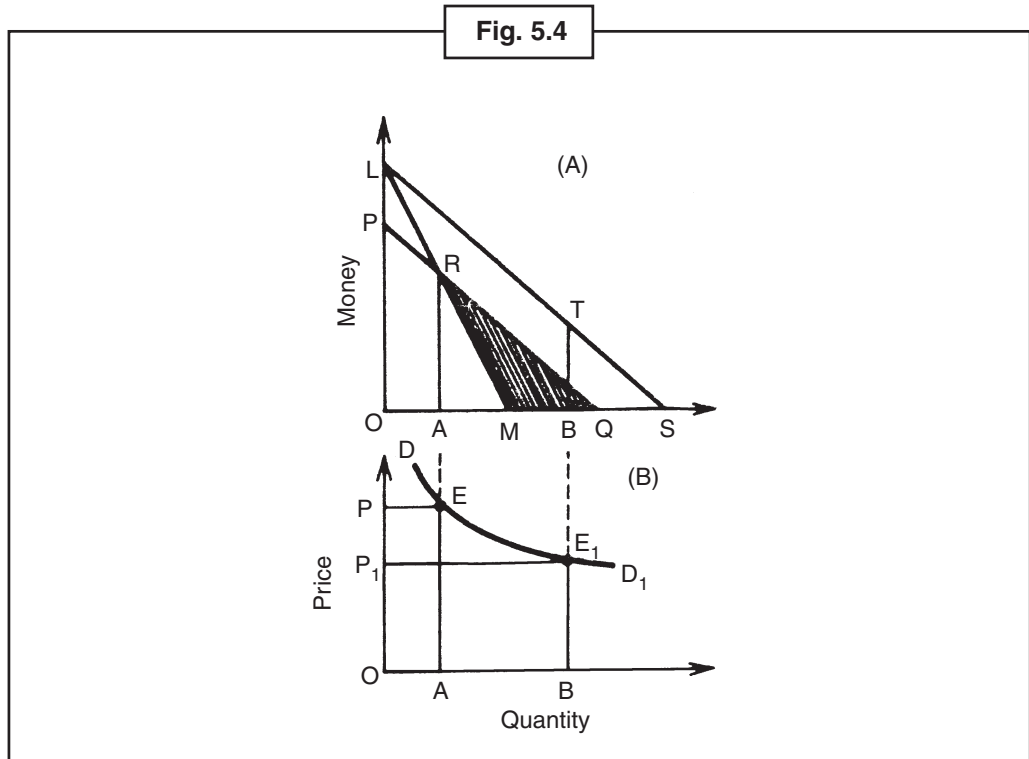

Now that amount has been taken back from consumer which is equal to LP and because of the price fall of X. Thus, PQ is his new price income line which is parallel to line LS and crosses from point R. The new triangle OPQ is his selection region. Since consumer was revealing his preference on point R of original price income line LM, so none of the points are matched with his selection from above the point R on RP of PQ line. Because of this he cannot buy more quantity of X due to price fall. So he will reject all the combinations above R or he will select R or any similar combination from shaded triangle MRQ. If we return the money PL to him, he will again on point T of price line LS where he buys more quantity of X i.e. OB. In panel (B), the movement from point R to T has shown by drawing demand curve.

Since we have taken price on vertical axis on panel (A), so to calculate the price of product X, we divide the total price income of consumer with the brought quantity of X. When the price of X is  $OL/OM (= OP)$ , then demanded quantity is OA. When the price of X gets low  $OL/OS (= OP_1)$  then demanded quantity is OB. In Fig. 5.4 panel (B), we take price on vertical axis and the units of product X in parallel axis and draw a line of this price quantity combination on E and  $E_1$ , and by adding this with a simple line, we get  $DD_1$  demand curve. This curve indicates that when price falls from OP to  $OP_1$ , then consumer buys more quantity of X i.e., AB.

### 5.4 Derivation of Indifference Curve from Revealed Preference

The theory of derivation of revealed preference of Prof. Samuelson is used to draw an indifference curve rather than to draw a technical indifference curve. In indifference curve technique we can assume that an indifference curve is drawn by asking consumer to select from all the combinations of product. However, the consumer will not or will not be able to give answer to all his preferences. According to revealed preference theory, we can assume a consumer's preferences and can create the indifference curve for market without directly checking the preferences of consumer. Now indifference curve technique believes that consumer do take the combinations as per his heart and matching. But in revealed preference theory

a consumer does not need to give information regarding his tastes or lines to his preferences. But to use the consumer market behaviour and applying revealed preference, an upward indifference curve is drawn.

### Its Assumptions

This analysis is based upon following assumptions:

1. The taste of consumer do not change.
2. He always gives preference to the combination of more products rather than the combinations of fewer products.
3. The behaviour of consumer is identical means if preference is given to A than B in a condition then in the other condition, B is not getting more preference than A.
4. There is motion in consumer's preferences. It means if A is getting more preferences than B and B is more than C, then consumer will prefer A rather than C.
5. X and Y are two products.

If this assumption is given consumer would give preference to the combination of two products rather than other combinations, either the selected combination is more preferable to him or the combination which is not selected is out of his pocket range.

Suppose that in Fig. 5.5, consumer represents his preference to combination R on original budget line LM. On line LM and all points below point R show the inferior combinations. This is shown by shaded region which is called inferior zone. On the other hand, above R and/or in TRS region, all points are preferred by R, because the quantity of X and/or Y is available more on it. So the shaded region TRS above R is called Preferred Zone. However, in the left and right side of R above the TRS region and above LM line, two combinations are found which are not directed by the consumer. They are called TRL and SRM which are called Ignorance Zone, because there is no idea about consumer preferences on it. This result to cross R is must for below TRS region and above the budget line LM. The slope should must be positive in point R and should upwards to original point, because this ignorance would locate in above and ground region.

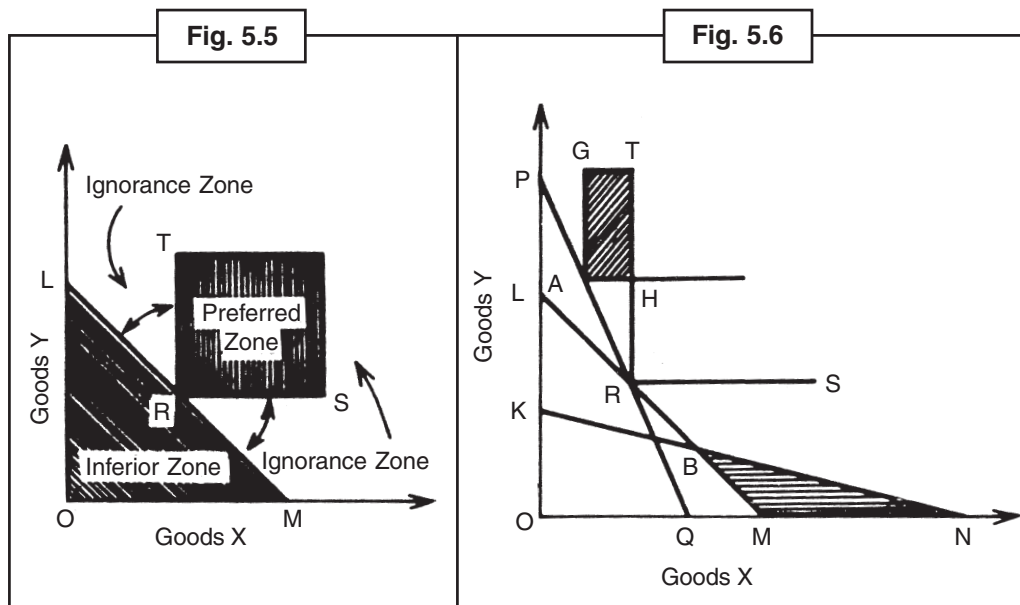

Thus the new budget line for consumer is KN. In Fig. 5.6 which crosses point B on point R in original line LM. Now consumer will choose the combination B or the other combinations of BN of line KN.

**Notes**

All the points would not match with him on the left side of B on this line KB. Since consumer selects combination B, it looks like more inferior to R and all the points above and below of BN look inferior. Thus, triangle BNM has been cut by below ignorance region. To draw these types of budget line in point R and by giving this type of fact, all the portions can be removed from the below ignorance region R.

Thus, we can cut the left side of R on above ignorance region in Fig. 5.6. Suppose that the price of X increases and the new budget line PQ crosses the original point R, which indicates that real income is on point R. Now consumer selects a new point A on budget line PQ. Thus he reveals preference for A rather than R, because both the points are on a single budget line. But A gets preference on the right side of A and the above GAH region. Because this region represents those combinations on which a product's quantity is greater than the product combinations of A. This can be understood as because A is preferable to R and GAH region is preferable to A, so GAH is preferable to R. Thus in GAHT region by ranking the combinations and giving preference to R, we remove some of the upper parts or ignorance region. To duplicate this process, we do lessen the ignorance region and established the indifference region, which is shown by I curve in Fig. 5.7.

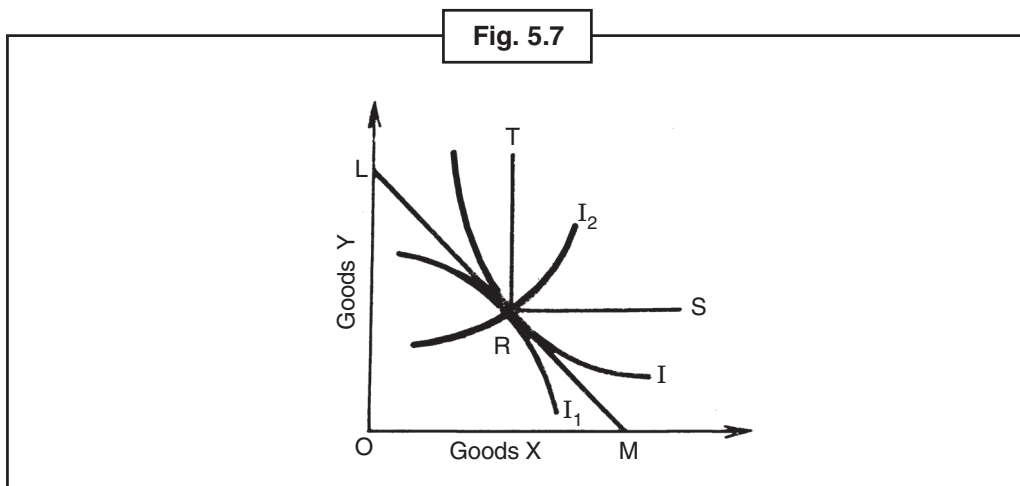



Figure 5.7 shows the shape of indifference curve as I curve is convex to its original in point R because it crosses the below and above ignorance region. To give more proof, first we assume LM as simple line indifference curve. Line LM cannot be indifference curve, because the selection of R on all the points indicates all points are inferior than R and consumer cannot be indifferent in the same time in between all points of point R and LM. Second, it cannot be like  $I_2$  curve which cuts LM line on point R because all the points below this level are inferior than R and consumer is indifferent towards it. Third, it cannot be concave as indifference curve  $I_1$  which crosses R because the above and below regions are inferior region and all points are revealed inferior than R. So the indifference curve can only be convex to its original as shown IC curve in Fig. 5.7.



*Did u know?* By analyzing the market behaviour of consumer a convex indifference curve can be drawn by revealed preference?

### 5.5 Superiority of Revealed Preference Theory

The revealed preference theory is more superior than the analytical numerical theory of Hicks which is more related to the theory of consumer behaviour.

1. This does not study any psychological internal information of consumer behaviour. But it gives the analysis by analyzing the consumer behavior in market. According to **Samuelson**, this theory has removed the demand theory from the last leftovers of psychological analysis. So the revealed preference theory is more scientific and real than earlier demand theorems.
2. This theory is left to get in touch from the **continuity** of both used and indifference curve. An indifference curve is a curve, on which consumer can select any combinations of the products. But **Samuelson** believes that this is a discontinuity because consumer can only get single combination. By applying Samuelson's theory, **Hicks** has applied strong and weak ordering in spite of continuity and assumption in his *Revision of Demand Theory*.
3. The Revision of Demand Theory of **Hicks** is based on this theory that the consumer is prudent to fulfill his satisfaction by his given income. The Demand Theorem of **Samuelson** is good because it does not assume that the consumer always wants to get maximum satisfaction and does not apply the bogus theory like decreased marginal theory of **Marshall** and decreased marginal relocation theory of **Hicks**.
4. In the first stage of **Samuelson's** Demand Theorem, as the subbing effect of **Slutsky** and the over compensation effects of **Hicks**, it gives more real analysis and data. When the price of product X decreases this theorem relocates the consumer to his up price income status and vice versa. This is revolution of **Hicks** income compensation change. Then, **Hicks** has left the income compensation theory and took **Samuelson's** thought as over compensation effect as 'Cost Difference' in his book *Revision of Demand Theory*. Thus, in the second stage **Samuelson's** theorem describes the income effect of **Hicks** in very simple manner. **Hicks** agrees with this theorem by himself when he said, "To present an open option to indifferent method, this theory is a new and very important theorem by **Samuelson**."
5. This theorem gives a base to welfare economics by consistent election of analysis.

## Self Assessment

### Multiple choice questions:

4. The income elasticity of demand is .....
  - (a) positive
  - (b) negative
  - (c) low
  - (d) more
5. Reveals Preference Theory is based upon .....
  - (a) order
  - (b) power
  - (c) more ordering
  - (d) point
6. The ..... of Samuelson is general and not conditional.
  - (a) theorem
  - (b) part
  - (c) theory
  - (d) law
7. Revealed Preference Theory is only based on personal .....
  - (a) consumer
  - (b) condition
  - (c) law
  - (d) theory



**Task** Give your opinion about Demand Theory.

## 5.6 Defects of the Revealed Preference Theory

There are lots of defects in **Samuelson's** revealed preference theory:

**First**, it clearly ignores the indifferent behaviour of consumer. It is quite correct that if a consumer selects a combination of product on point R then he does not represent his indifferent behaviour on

**Notes**

price income line or in any single price product. But it is possible there may be some more points on R as Fig. 5.8 like A and B which is shown in circle and consumer is always unconcerned about it. If we accept the criticisms of **Armstrong** then the base theorem of **Samuelson** can end. Suppose that the price of X increases and the new budget line of consumer is now LS. Now give him some amount that he can buy original combination point R on line PQ. Let's assume in this new price income condition, he selects point B below R. This is because **Armstrong** thinks that the consumer is unconcerned towards the nearer already selected points. But to select B in PQ price income condition means consumer buys more quantity of X when its price increases. Thus the base theorem of Samuelsson ends because if price of X increases, the demand is more rather than short.

**Second**, according to **Hicks** since revealed preference theory is based on **strong ordering**, so it cannot be assumed that all the points present in or out of triangle (OLM in our Fig. 5.8) describe the good solutions. The strong ordering of a two dimensional continuum is not possible. So there is no option to assume that the product comes in various units, so Fig. 5.8 can only be drawn in squared paper and powerful options can only stable in the corner angles. Point R would also present in square angle.

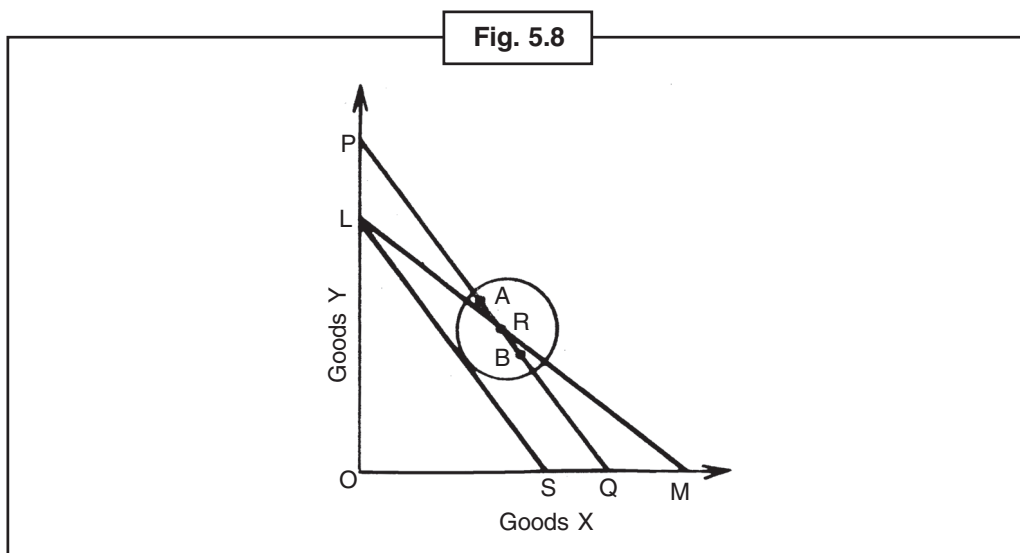

**Third**, the base theorem of **Samuelson** is conditional and not simple. This is based on the condition that negative income elasticity is present within positive income elasticity. Since the income effect is created by income and substitution effect, so in analysis point of view, the income effect cannot be separated from substitution effect. If income effect is not positive then demand of price elasticity would be indefinite. On the other hand, if income elasticity of demand is positive, then we cannot establish the substitution effect due to changes in price. So the income effect and substitution effect cannot differentiate in **Samuelson's** theorem.

**Fourth**, the revealed preference theory of **Samuelson** has not given the solution of **Giffen's** paradox because it only studies on positive income elasticity of demand while **Giffen's** paradox is related to negative income elasticity. As per the demand theory of **Marshall**, the theorem of **Samuelson** is also not differentiating between these two. The positive income effect of substitution effected **Giffen's** product while on the other hand, powerful substitution effected positive effect. Thus the theorem of **Samuelson** is inferior and less working than the price effect of **Hicks** and **Allen**.



## Self Assessment

State whether the following statements are True/False:

8. Selection indicates preference.
9. The theory of **Hicks and Allen** is better than revealed preference theory.
10. Revealed Preference Theory is real and scientific than earlier demand theories.

**Fifth**, the assumption that consumer selects only one combination on given price income condition is wrong. It means consumer selects little from both the products. But it is almost impossible that a person buys some parts of products.

**Sixth**, this assumption is also criticized that selection reveals preference. The consumer always thinks before buying. But since a consumer not always thinks and buys the product, so buying of product cannot indicate that the consumer reveals preference. So this theorem is not based on the market behaviour of consumer but this is an unreal practice like all other economical theorems.

**Seventh**, the reveals preference theorem applies only in particular consumer. By this theorem, all other things are constant; the negative sloped demand curve can be drawn for all the consumers. But this technique does not help to draw the market demand schedule. Because if the price of X falls in market, it can affect all other products and which can change the real income factor. However, for this product X, the demand curve is sloped downward for the entire consumer, but in a specific region of price, to redistribute the real income, the demand curve sloped upwards too. The theory of **Hicks and Allen** is better than revealed preference theory because it can draw both demand curves of consumer and market from price consumption curve.

**Eight**, according to **T. Mazumdaar**, the revealed preference theory is impossible for those conditions where individual selector is unable to use diplomacy.

**Lastly**, the revealed preference theory is unable to analyze the behaviour of consumer in selecting dangerous or indefinite selections. If there are three conditions A, B and C then consumer gives preferences to A rather than B and C rather than A. A is definite from it but possibility of B or C is 50-50. In this situation, to give more preference to C than A is not based on an observed behaviour.

## 5.7 Summary

- In this analysis, it shows that revealed indifference theory is not a correction of the substitution analysis of **Hicks and Allen**. It does not differentiate substitution effect from income effect, left **Giffen's** paradox and does not analyse the market demand. But to publish the consumer behaviour rather than one price product makes revealed preference theory is more real than substitution curve technique. Thus, this analysis of **Samuelson** is clear option of internal numerical theorem of **Hicks and Allen**.

## 5.8 Keywords

- **Origin:** Origination
- **Zone:** Place
- **Revealed:** Displayed

## 5.9 Review Questions

1. What do you mean by demand of theory?
2. What do you mean by decrease in price?
3. What do you mean by Revealed Preference Theory?
4. Describe the demerits of Revealed Preference Theory.



Notes

**Answers: Self Assessment**

- |                  |                |           |         |
|------------------|----------------|-----------|---------|
| 1. Numerological | 2. Imagination | 3. Change | 4. (a)  |
| 5. (c)           | 6. (a)         | 7. (a)    | 8. True |
| 9. True          | 10. True       |           |         |

**5.10 Further Readings**



*Books*

1. **Microeconomics: An Advance Treatise** – *S.P.S. Chauhan, PHI Learning.*
2. **Microeconomics: Behaviour, Institutions and Evolutions** – *Samuel Bowles, Oxford University Press, 2004.*
3. **Microeconomics: Principles, Applications and Tools** – *Sanjay Basotiya, DND Publications, 2010.*

## Unit-6: Theory of Demand and Elasticity of Demand

### CONTENTS

Objectives

Introduction

- 6.1 Concept of Demand
- 6.2 Demand Schedule and Demand Curve
- 6.3 Determinants of Demand or Demand Function
- 6.4 How do Different Determinants Work?
- 6.5 Change in Quantity Demanded and Change in Demand

Or

Movement Along Demand Curve and Shift of the Demand Curve

- 6.6 Distinction between Extension and Increase in Demand
- 6.7 Distinction between Contraction and Decrease in Demand
- 6.8 Elasticity of Demand
- 6.9 Price Elasticity of Demand
- 6.10 Two Extreme Situations of Price Elasticity of Demand
- 6.11 Normal Situations of Price Elasticity of Demand
- 6.12 Demand Curves Showing  $E = 1$ ,  $E > 1$  and  $E < 1$
- 6.13 Measurement of Price Elasticity of Demand
- 6.14 Some Theorems Related to Elasticity of Demand
- 6.15 Factors Determining the Price Elasticity of Demand
- 6.16 Income Elasticity of Demand
- 6.17 Measurement of Income Elasticity of Demand
- 6.18 Degrees of Income Elasticity of Demand
- 6.19 Cross Elasticity of Demand

Notes

- 6.20 Measurement of Cross Elasticity of Demand
- 6.21 Nature and Degrees of Cross Elasticity of Demand
- 6.22 Importance of Price Elasticity of Demand
- 6.23 Summary
- 6.24 Keywords
- 6.25 Review Questions
- 6.26 Further Readings

## Objectives

After studying this unit, students will be able to:

- Know about Concept of Demand.
- Learn about Price Elasticity of Demand.
- Know about Income Elasticity of Demand
- Understand about Cross Elasticity of Demand.

## Introduction

'Demand' word is used in a specific meaning in economics. Generally Desire, Want and Demand are used in a particular meaning, but in economics, these three words have different meanings. Desire is a wishful thinking. If you wish to buy a colour T.V. but you do not have enough money so economically, wish or want is only **Desire or Wishful Thinking**, not the demand and if you do not want to spend on a colour T.V. after having sufficient money, then this wish will only be called as **Want**, not the demand.

## 6.1 Concept of Demand

In economics, Demand word is used in a specific meaning. Generally Desire, Want and Demand are used in a particular meaning, but in economics these three words have different meanings. Desire is a wishful thinking. If you wish to buy a colour T.V. but you do not have enough money so economically, wish or want is only **Desire or Wishful Thinking**, not the demand and if you do not want to spend on colour T.V. after having sufficient money, then this wish will only be called as **Want**, not the demand. This want, only in that situation will terminate in

*In an Independent Market Economy, Demand of a commodity has not any independent identity without context of price. Demand is always estimated in the context of price.*

Demand in which on a given time period and a given price, you are ready to buy a colour T.V. As this, Demand should be defined in the context of a given price and a given time period. Demand is defined as the quantity of a product which a consumer is not only desiring to purchase and able to purchase but is also ready to purchase at a given price and a given point of time. In other words, this refers the relation between the Price and Demand. This indicates that at different prices, how much quantity of a commodity will be demanded. Here, it is necessary to let you know

that Economics defines the difference between concepts of demand and quantity demanded. Demand is the quantity that buyers are willing and able to buy at alternative prices during a given period of time. Opposite to it, the quantity demanded is a specific amount that buyers are willing and able to buy at given price. For example, on one rupee per ice-creams, the ability and willingness to buy 4 ice-creams by consumer is an example of quantity demanded, whereas 4 ice-creams at ₹ 1, 3 ice-creams at ₹ 2, 2 ice-creams at ₹ 3 ability and willingness to buy by consumer is an example of demand.

**About the Concept of Quantity Demanded,  
Two Important Views:**

- i) *About specific price, quantity demanded does not actual purchase of buyer. This is only Intended Purchase or a quantity which consumer wants to purchase.*
- ii) *Quantity demanded is a flowing concept not a stock concept. Its meaning is not for a different purchase but also for a continue flow purchasing as everyday 2 ice-creams, per week 100 oranges etc. In floating variables (as Demand) time is size whereas in stock variable it's not in size.*

**Demand refers to the quantities of a commodity that the consumer are able and willing to buy at every possible price during a given time period, other things being equal.**

–Ferguson

**Difference between Demand and Quantity Demanded**

*Demand refers to a demand schedule constituted in the mind by consumer which expresses that he wants how much quantity purchased on these possible price of anything. Oppositely quantity demanded refers to a fixed quantity of anything that consumer wants to buy at given price.*

According to B.R. Schiller, “Demand is the ability and willingness to buy specific quantity of a commodity at alternative prices in a given time period, ceteris paribus.”

## 6.2 Demand Schedule and Demand Curve

As per McConnell, “Demand Schedule is a table that shows different price of a good and a quantity of that commodity demanded at each of these prices.”

In other words, demand schedule shows those different quantities of the goods which an individual wishes to buy at all possible prices at a given time period. This is of two types: (1) Individual Demand Schedule and (2) Market Demand Schedule.

### Individual Demand Schedule

**Individual demand schedule is defined as the table which shows quantities of a given commodity which an individual will buy at all possible prices at a given time.**

Table 1 is an individual demand schedule. The different quantities of an ice-cream bought at different prices at a time by an individual has been shown in this table.

Per unit price (₹)	Quantity Demanded
1	4
2	3
3	2
4	1

**Notes**

It is known from the given table that as the price of an ice-cream increases, its demand decreases. When ice-cream costs ₹ 1 per unit then 4 units are demanded and when it costs ₹ 4 per unit, then it is demanded 1 unit only.

**Market Demand Schedule**

According to Leibhafsky, "Market demand schedule is defined as the quantities of a given commodity which all the consumers will buy at all possible prices at a given period of time." In every market, any commodity like sugar has many consumers. When total demand of all the consumers of a commodity at different prices in the market is shown by the table, then the table will be known as Market Demand Schedule. In other words, it mentions the total demand of all the consumers of a specific commodity at different prices in a given time. Table 2 is Market Demand Schedule. By the simple view, this table is based on that A and B consumers of X- commodity. Adding their individual demands, market demand schedule is developed.

Table 2: Market Demand Schedule			
Price of X-object (₹)	Demand of A	Demand of B	Market Demand (Units)
1	4	5	4 + 5 = 9
2	3	4	3 + 4 = 7
3	2	3	2 + 3 = 5
4	1	2	1 + 2 = 3

According to the above table, when X-object has ₹ 1 per unit price, Consumer A demands 4 units and Consumer B demands 5 units. So Market Demand is 9 units. When price increases with ₹ 2 per unit, Market Demand decreases with 7 units etc.

*Market Demand in market is the sum of total Demand by all consumers of a commodity.*

**The Demand Curve is a graphic presentation of a Demand Schedule.**

In the words of Leftwitch, "The Demand Curve represents the maximum quantities per unit of time that consumers will take at various prices."

As per Lipsey, "The curve, which shows the relation between the price of a commodity and the amount of that commodity the consumer wishes to purchase, is called Demand Curve."

Like Market Demand, Demand Curve can also be of two types– (1) Individual Demand Curve (2) Market Demand Curve.

- 1. Individual Demand Curve:** Individual Demand Curve is that curve which shows the demanded quantity of a commodity by a consumer at different prices of that commodity which shows the

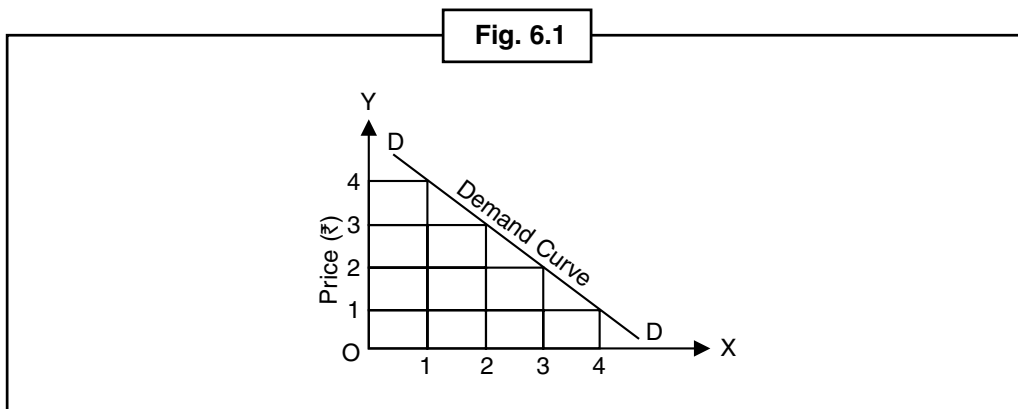

Notes

demand of commodity on OX-axis and price on OY-axis. DD is Demand Curve. Every point of this demand curve DD shows the relation in price and demand. When price is ₹ 2, demand is 1 unit. When price is ₹ 1, demand is 4 units. Slope of this demand curve flows from upper left side to lower right side, which shows more prices and less demand and fewer prices and more demand.

2. **Market Demand Curve:** Market Demand Curve indicates the summation of quantities demanded by the different consumers on different prices of a specific commodity. This Demand Curve draws with the summation of all individual demand curves.

*Market Demand Curve is summation of all individual demand curves.*

Figure 6.2 refers to the Market Demand Curve on the base of Demanded Table 2.

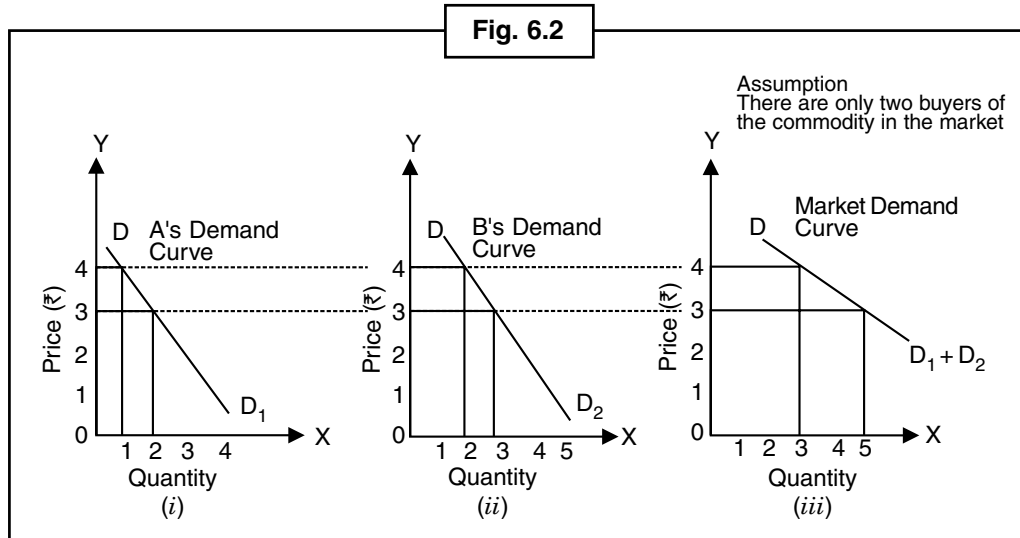

In Fig. 6.2 OX-axis represents the quantity and OY-axis represents price. Figure 6.2 (i) shows A's Demand Curve and in Fig. 6.2 (ii) B's Demand Curve and in Fig. 6.2 (iii) Market Demand Curve are shown. When price is ₹ 4 per unit, A's Demand is 1 unit and B's Demand is 2 units. If in market there are only two consumers, then market demand will be 1 + 2 = 3. By horizontal summation of Individual Demand curves, you can find Market Demand Curve, so its slope is negative.

**Self Assessment**

**Fill in the blanks:**

1. Demand is a schedule which shows different ..... of a commodity and refers quantity demanded of that commodity on each price.
2. Generally, demand of any commodity is fixed by its .....
3. In between consumer's income and demand of commodity, generally ..... relation founds.

**6.3 Determinants of Demand or Demand Function**

Here let us differentiate between Individual Demand Function and Market Demand Function. Individual Demand Function studies the **Functional Relationship** between demand for any commodity (with an individual buyer) and its Determinants. Market Demand Function studies with the functional relationship between Market Demand for any commodity and its different Determiners. **Individual Demand Function** can be expressed as –

$$Q_x = f (P_x, P_r, Y, W, T, E)$$

**Notes**

(Here  $Q_x$  = Quantity Demanded of Object-X;  $P_x$  = Price of X;  $P_r$  = Price of Related object;  $Y$  = Customer Income;  $W$  = Customer's Property;  $T$  = Choices and hobbies of customer;  $E$  = consideration and possibilities of customer.)

Its inverse, **Market Demand Function** can be expressed as

$$Q_x = f(P_x, P_r, Y^*, T, Z, W, E)$$

(Here  $Q_x$  = Quantity Demanded of Object-X;  $P_x$  = Price of X;  $P_r$  = Price of Related object;  $Y^*$  = Customer Income and its distribution;  $T$  = Choices and hobbies of customer;  $Z$  = size and shape of population;  $W$  = Customer's Property;  $E$  = consideration and possibilities of customer.)

**Note:** Determinant  $Y^*$  and  $Z$  are just different in Market Demand Function. Demand of any specific person (further Individual Demand Function) has no relation or concern with the income distribution in Economic and size and shape of population. But in further Market Demand they are determinants.

**To Remember**

Some determinants of Demand as (1) Size and shape of population and (2) Distribution of Income confirm the market Demand. If here raise a question about Determinants of Demand of a customer, and then it should not be defined to students. Reason is that when a customer decides to buy how much quantity he does not care about the size of population and income distribution.



Notes

Demand is defined as the quantity of a matter to which a consumer is not only willing and able to buy on a given price in a given time period but also ready for this.

**6.4 How do Different Determinants Work?**

**1. Price of Commodity**

Generally, demand of any commodity is confirmed by its price. If other determinants remain constant or *Ceteris Paribus*, then by the change in price of commodity, its demand is also changed inversely. Normally, on rising, price of commodity demand decreases and inversely on decreasing price Demand increases. This relation of demand is known as Law of Demand. The following figure shows it.

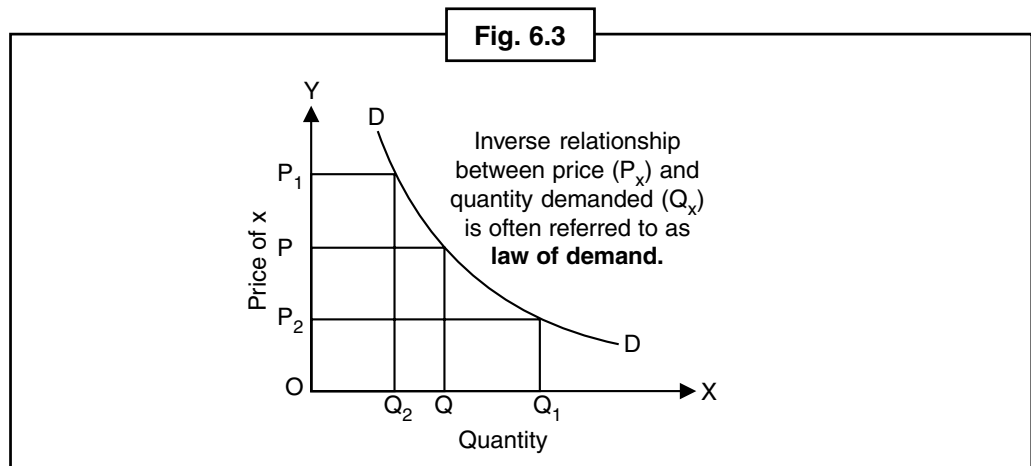

In Fig. 6.3, on decreasing price of commodity from  $OP$  to  $OP_2$  its demand is increased from  $OQ$  to  $OQ_1$  and on increasing price from  $OP$  to  $OP_1$  demand is decreased from  $OQ$  to  $OQ_2$ , this fact refers to a reality that there is a inverse relationship between price and its quantity demanded.

## 2. Prices of Related Goods

Notes

Demand of a commodity depends not only on its price but also on prices of related goods. Commodities are classified by general phase in Substitute Goods and Complementary Goods.

- (i) **Substitute Goods:** Substitute Goods are those which are used in place of each other as Tea and Coffee or Pepsi Cola and Coca Cola. Price of Coca Cola is related to Price of Pepsi Cola. If Pepsi Cola's price increases, then people will demand more Coca Cola and If Pepsi Cola's price decreases, then Coca Cola's Demand will decrease. In other words, about **Substitute Goods Quantity Demanded of a commodity is directly related the other or substitute goods**. If commodity such as Coca Cola's price increases then its substitute like Pepsi Cola's demand will increase. Inversely if Coca Cola's price decreases, its substitute Pepsi Cola's demand will decrease. By Fig. 6.4 we can see this relation –

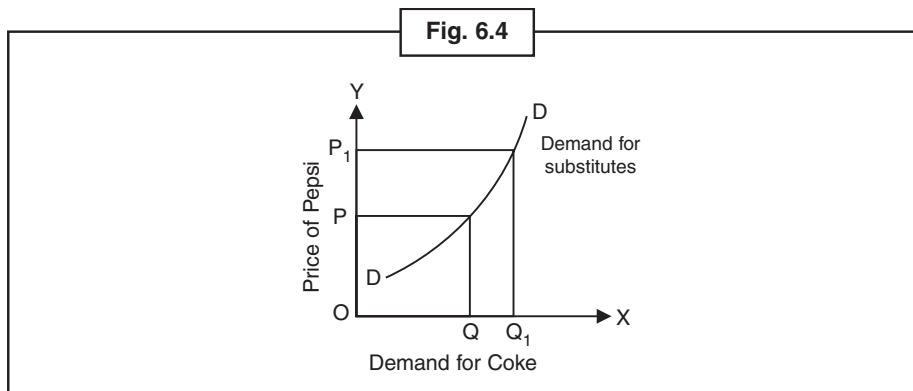

Figure 6.4 shows that an increasing rate of Pepsi Cola from  $OP$  to  $OP_1$  demand of Coca Cola increased by  $OQ$  to  $OQ_1$ .

- (ii) **Complementary Goods:** Complementary Goods are those goods which are used together and whose usability depend upon each other such as Car and Petrol, Pen and Ink. Complementary Goods, prices and Demands are inversely or negatively related. Complementary goods such as pen its increasing rate decreases the demand of Ink (with the pen's demand). Inversely on decreasing rate of pen, ink's demand increases. In other words, if two goods are complementary of each other and if one's price increases the other complementary good's demand will increase. Inversely, if one's price decreases, then the other complementary good's demand will increase. It can be shown clearly by Fig. 6.5.

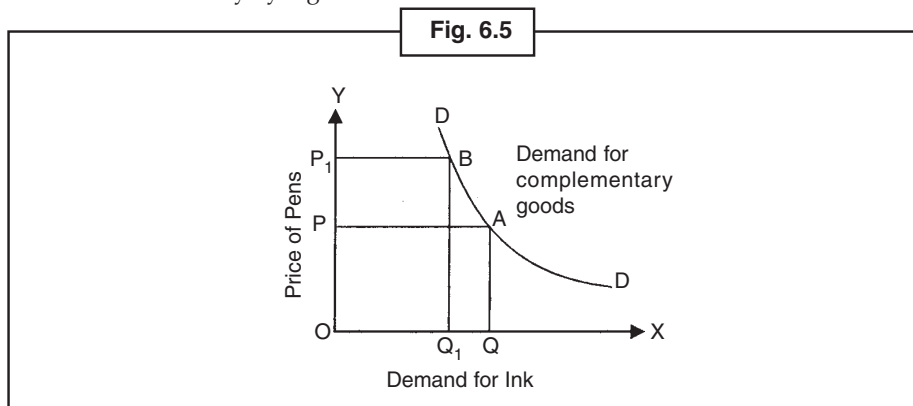

Figure. 6.5 shows ink's demand is decreased from  $OQ$  to  $OQ_1$  to increase in price of pens.

So in the case of Substitute goods, curve is positively sloped whereas in the case of Complementary goods curve is negatively sloped.



Notes

3. Income of Consumer

In between income of the consumer and demand of commodity generally a relation is found. On increasing in income demand of goods increases and on decreasing of income demand decreases. In economics such goods are known as **Normal Goods**. **Normal goods are goods whose demand increase with the increase in the income of consumer.** Some goods are also of a type that is known as Inferior Goods. Inferior goods are goods whose demand increase with the increase in the income of consumer. So, demand of a commodity and income of the consumer can be related as following in the context of three classes:

- (i) Normal Goods, (ii) Inferior Goods, and (iii) Necessaries of life and Inexpensive goods

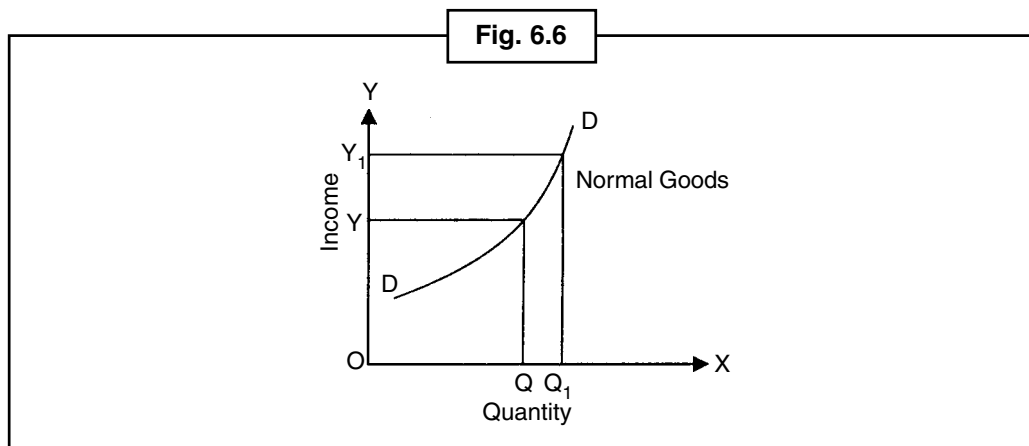

- (i) **Normal Goods:** Normal goods are goods whose demand increase with the increase in income of the consumer and decrease with the decrease in income. In this way, there is a true or positive relation between income of consumer and quality demanded, this is shown by Fig. 6.6. It is clear from Fig. 6.6 that demand of goods shows the increase from  $OQ$  to  $OQ_1$  to increase in the income of consumer. Slope of demand curve  $DD$  goes from left to right in upper side which refers to true or positive relation of income and quantity demanded.
- (ii) **Inferior Goods:** Inferior or poor quality goods are goods whose demand decrease with the increase in income of consumer and increase with decrease in income. In this way, there is an inverse relation between income and demand of inferior goods. Figure 6.7 shows this relation.

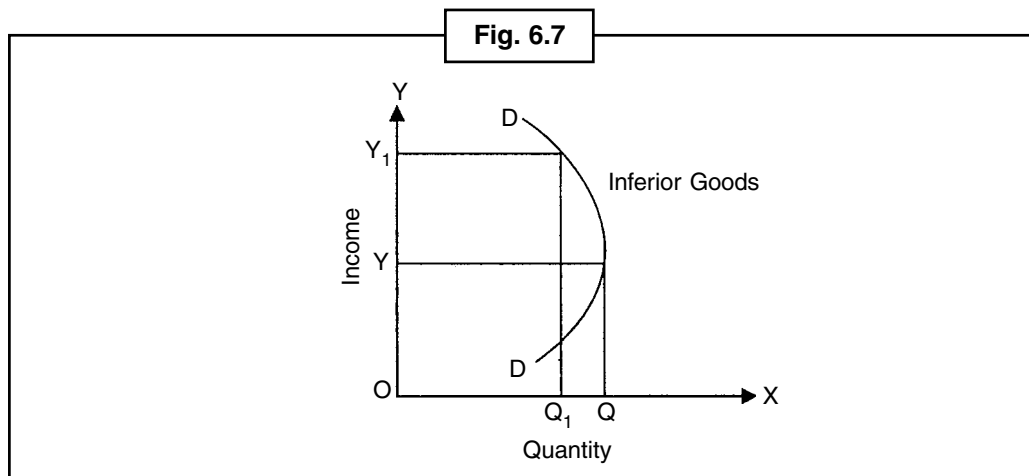

It is shown in Fig. 6.7 that demand of X-goods (which are Inferior goods)) is decreased from  $OQ$  to  $OQ_1$  to increase in the income of consumer from  $OY$  to  $OY_1$ . Its reason is that consumer on increasing the income started to use good quality goods in place of poor quality goods. Hence, for poor quality goods income-demand curve sloped negatively.

- (iii) **Necessaries of life and Inexpensive goods:** It is mandatory to study the relation between income of consumer and necessaries and Inexpensive goods such as salt, matches, pulses etc., there is not any effect to increase in income of consumer after a limit or can say demand remains constant. In the starting when income is very low, then on increase in it demand increases but after a limit demand is not affected by the increase in income. This is shown in Fig. 6.8.

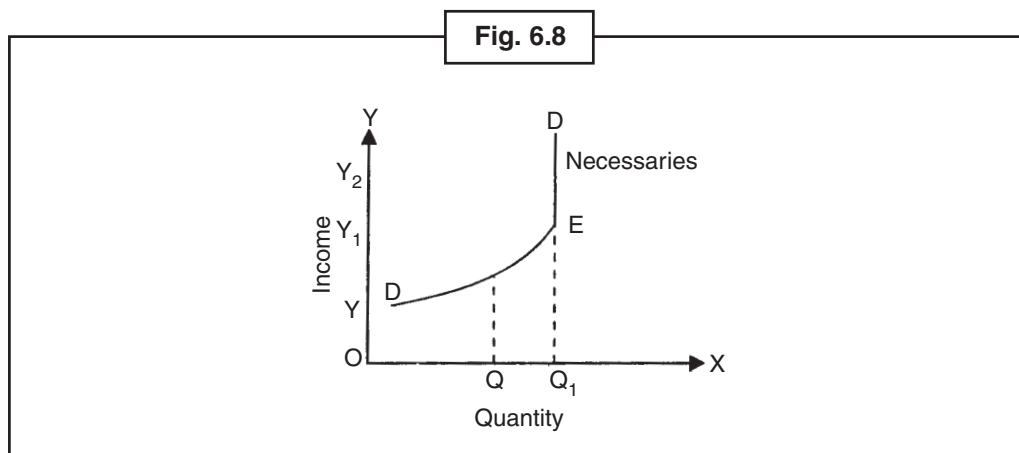

Figure 6.8 shows that income of consumer is then increased from  $OY$  to  $OY_1$  demand is increased by  $OQ$  to  $OQ_1$ . It means demand has just a moderate stretch. After this situation, demand becomes unstable. Income became  $OY_2$  or more than this value, there is not any change in demand, parallel to Y-axis, vertical stretch part ED of demand curve indicates the stability of demand.

4. **Taste and Preferences:** Demand of anything or service depends upon the taste and preferences, these words are used in maximum extensive senses. Fashion, traditions etc. are included in it. Taste and preferences of consumers are affected by advertising, fashion modification, climate, weather etc. Consumers' taste and preferences are increased for those things whose demand has also increased. Inversely, when unfavorable changes occurred in tastes and preferences, demand came to fall.
 

*Taste and preferences indicate (1) individual likes and dislikes (2) fashion (3) climate or weather.*
5. **Expectations:** Expectations of consumer related to future changes in prices, requirements and future income, etc. are the other determinants of demand. If consumer expects that in future prices will increase then he will purchase more quantity of commodity in present, even if it has more price. In this way if consumer hopes that prices will go down in future, he will postponed or less demand of commodity in present. Present demand is also affected by the expectation of fall or rise in income in future. There is a direct relation between expecting demand increment of income and demand of commodity. In future demand is increased if increment expected and fears of decrement in income increase the demand in future.
6. **Size and Composition of Population:** Market demand is affected by the size and composition of population. Demand of all goods is increased to increase in population and decreased to decrease in population. Also composition of population affects the demand. Composition of population

**Notes**

means that how many children, teenagers, men, women etc. in population. If there comes a change in composition of population as number of women increased, demand of those goods will increase which are bought by women.

7. **Distribution of Income:** Distribution of income to be in future in society also affects the market demand. If distribution is unequal, the usable luxury goods such as T.V., automatic washing machine, video camera etc. will be more demanded by rich people. On the other hand, distribution of income is equal, then demands of luxury goods will decrease and compulsory and comfortable goods will be more demanded.



*Did u know?* Normal goods are those whose demand increase with the increase in the income of consumer.

## 6.5 Change in Quantity Demanded and Change in Demand

Or

### Movement Along Demand Curve and Shift of the Demand Curve

According to Economists, **“Change in quantity demanded and change in demand related concepts are different.”** Change in quantity demanded refers to effect on demand to change in the rate of goods whereas other determinants of demand such as income, taste and price of other goods remains constant or stable. Because quantity demanded on a given price is shown by a point on the demand curve, so change in the quantity demanded has showed with the different points on same curve or movement along a demand curve. Inversely, change in demand is not done due to changes in prices of goods; it indicates the effect in demand of consumer for goods due to change in income, taste, price of other goods, whereas price of goods remains stable. Change in demand shows to shift or slip of complete curve from left to right side. Both different types of change in demand are important. Movement along demand curve on some demand curves or change in quantity demanded represents the coordination in quantity demanded by consumer due to the change in market price. Inversely, shift of demand curve represents the coordination of consumer and upcoming changes in balanced prices and quantity related to changes in outside matters (as income, taste, price of other goods etc.).

#### 1. Change in Quantity Demanded or Movement Along the Demand Curve

When quantity demanded is changed only due to the change in price, then change in demand is represented by the different points on same demand curve. Rise in demand is called extension of demand to fall in price, and falling in demand is called contraction of demand to rise in price. In brief, movement along a demand curve response to price changes for those goods. In these movements it is accepted that demand has other unchangeable determinants besides the price. A given demand represents the changes in quantity demanded on the graph due to change in price of the moving object. In brief,

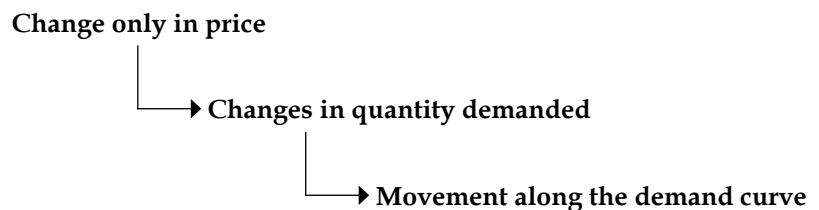

Quantity demanded can be of two types:

Notes

- (i) **Extension of demand** – Extension of demand refers to a size in the demanded as a result of fall in price. As shown in table 3, when rate of apples is ₹ 5 per Kg then demand of apple is 1 Kg and when price decreases to ₹ 1 per Kg the demanded expanded to new demand of 5 Kg apples.

Price (₹)	Quantity Demanded (Kg)	Description
5	1	Rise in price ↓
1	5	Extension in demand

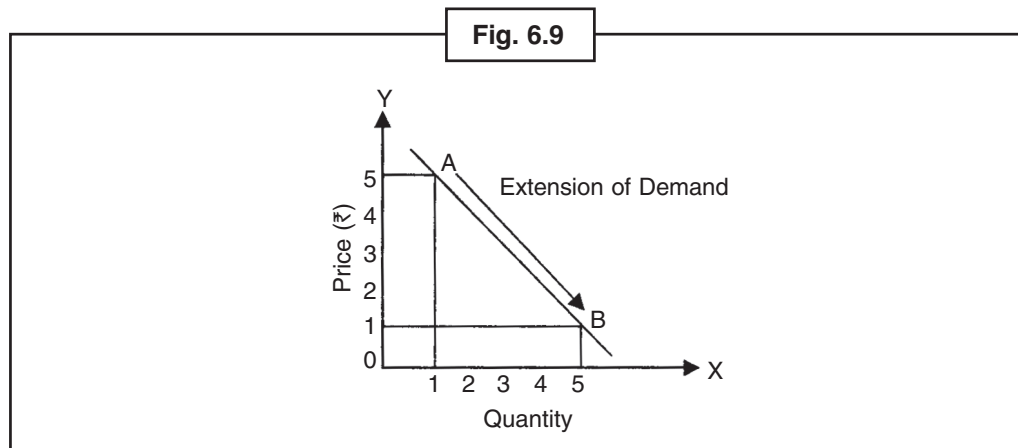

The Extension of Demand is represented by the above figure.

In this figure AB is the demand of apples. When price of apples is ₹ 5 per Kg, demand is 1 Kg. Consumer is on the point 'A' of demand is extended to new demand of 5 Kg and consumer is reached to point 'B' of demand curve. So, slip from upper point (A) to lower point (B) of demand curve shows the extension of demand.

- (ii) **Contraction of Demand:** Contraction of demand refers to fall in quantity demanded as a result of rise in price, ceteris paribus which is shown in Table 4 that if rate of apples is ₹ 1 per Kg, then demand is 5 Kg. If price rises to ₹ 5 per Kg then demand is contracted to new demand of 1 Kg.

Price (₹)	Quantity Demanded (Kg)	Description
1	5	Fall in price ↓
5	1	Contraction in demand

Notes

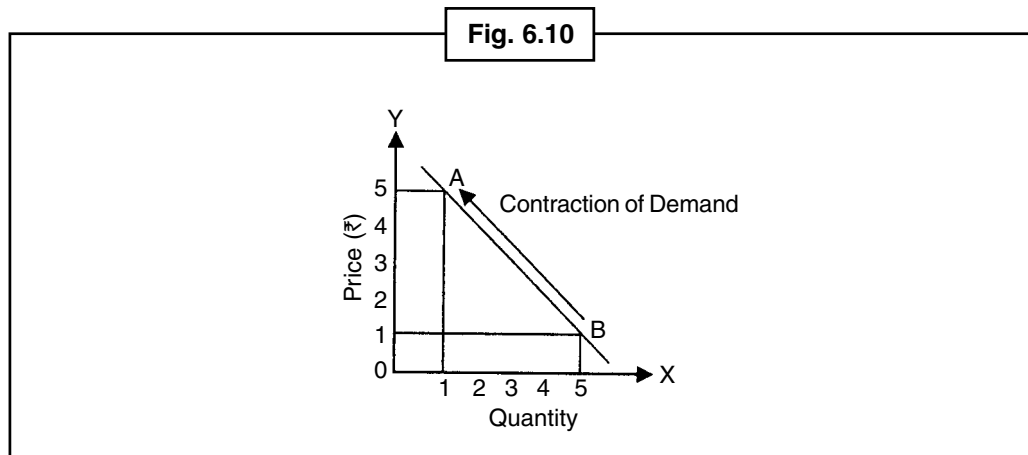

Contraction of demand can be expressed by Fig. 6.10. In this figure AB is the demand curve of apples. When rate of apples is ₹ 1 per Kg, demand is 5 Kg apples. Consumer is on the point 'B' on the curve. Inversely, when price increases to ₹ 5 per Kg, the demand contracted to new demand of 1 Kg and consumer reaches to point 'A'. So the shifting from lower point 'B' to upper point 'A' in demand curve shows the Contraction of Demand.

## 2. Change in Demand or Shift in Demand Curve

Change in any determinant of demand beside price shifts complete demand curve to left to right side. Rise in demand is shown by right side and decrease in demand is shown by left side shifting. Economists say it is change in demand. **Changes in demand** are the factors of changing in the income, taste, price of the other goods. In brief,

**Change in Income, Taste or Price of Related Goods**

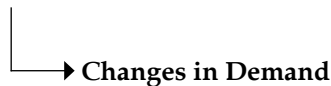

*Extension and contraction of Demand is defined as in the concept of changes in its prices. Rise and fall in demand is defined in context of other determinants besides price.*

Rightward shifting of curve shows a rise and leftward shifting shows the fall in the demand.

Decrease in demand or leftward shift in demand curve has following factors:

1. Decrease in income
2. Decrease in price of replacement goods
3. Increase in price of complementary goods
4. Unfavorable changes in taste, likes and preferences
5. Expectation of decreasing price in future
6. Decrease in population (buyers)

Just as this increase in demand or rightward shift in demand curve has following factors:

1. Increase in income
2. Increase in price of replacement goods

3. Decrease in price of complementary goods
4. Favorable changes in taste, likes and preferences
5. Expectation of decreasing price in future
6. Increase in population (buyers)

### Self Assessment

#### Multiple choice questions:

4. Normal goods are goods whose demand increase with the increase in income of ..... .  
 (a) consumer (b) person (c) replacement (d) common man
5. Inferior goods are goods whose demand is ..... on increasing income of consumer.  
 (a) decrease (b) less (c) increase (d) more
6. Decrease in demand is known as ..... to increase in price.  
 (a) contraction (b) curve (c) movement (d) distribution
7. Increase in demand is done when it is bought at stable price of goods ..... .  
 (a) in more quantity (b) in less quantity (c) in balanced quantity (d) nothing

## 6.6 Distinction between Extension and Increase in Demand

Extension of demand means, growth of demand due to fall in price of a commodity. It is shown by the movement at the same demand curve. On the other side, increase in demand means growth of demand due to the changes in other determinants of demand (such as tastes, income of consumer, price of replacement goods) on the stable price. It is shown by the shift or slip of complete demand curve.

Figure 6.11 is clearing the distinction between extension and increase in demand. DD is initial demand curve. It is known by Fig. 6.11 that two different growths are possible in the demand at point 'A' of DD demand curve. First is that quantity of demand to become OQ to OQ<sub>1</sub> on point 'B' with movement to point 'A' of same demand curve. This growth in quantity demanded is due to price to be decreased from

#### Distinction between Extension and Increase in Demand

*Demand of any commodity is extended when its more quantity is bought to fewer prices. Increase in demand occurs when by stable price of commodity its more quantity is bought.*

Fig. 6.11

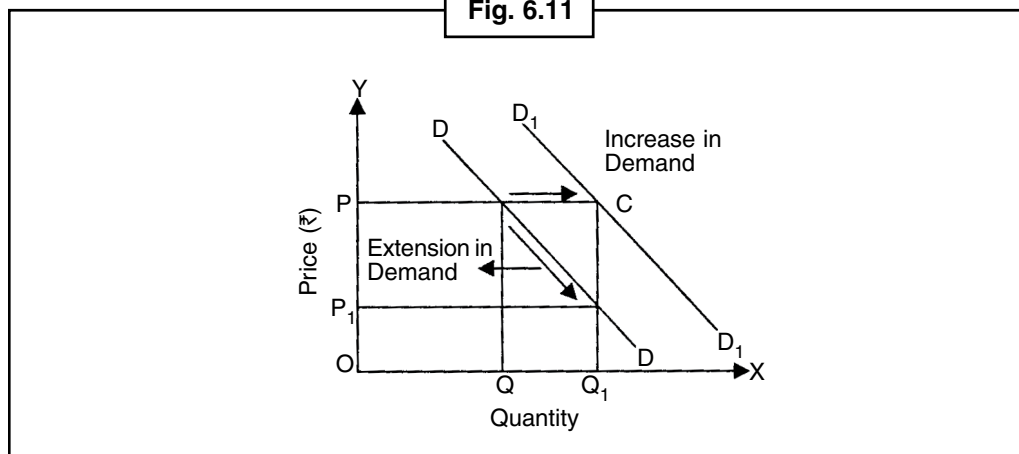

**Notes** OP to  $OP_1$ . It is known as extension in demand. Second is that complete demand curve DD slips to become  $D_1D_1$ . At the initial price OP consumer has to buy OQ quantity which is shown at point 'A' of demand curve, but besides price as a result of change in other determinants of demand, consumer buys  $OQ_1$  quantity which is shown by point 'C' at  $D_1D_1$  curve. This change is shown as increase in demand.

### 6.7 Distinction between Contraction and Decrease in Demand

**Contraction in demand means to decrease in demand due to increase in price of goods, Ceteris Paribus. It is expressed by the movement of same demand curve from lower point to upper point.** On the other hand, decrease in demand means to decrease in demand due to changes in the other determinants of demand besides price. It is expressed by the backward slip of demand curve.

**Distinction between Contraction and Decrease in Demand**

*Demand of any commodity is contracted when its less quantity is bought to more prices. Decrease in demand occurs when by stable price of commodity its less quantity is bought.*

Figure 6.12 is clearing to Distinction between contraction and decrease in demand. DD is initial demand curve. Two different growths are possible in the demand, at point 'A' of DD demand curve. First is that quantity of demand to decrease from OQ to  $OQ_1$  on point 'B' with movement to point 'A' of same demand curve. This growth in quantity demanded is due to price to be increasing from OP to  $OP_1$ . It is known as contraction in demand. Second is that complete demand curve DD slips to become  $D_1D_1$ . At the initial price OP consumer has to buy OQ quantity which is shown at point 'A' of demand curve, but besides price as a result of change in other determinants of demand, consumer buys  $OQ_1$  quantity which is shown by point 'C' at  $D_1D_1$  curve. This slipping (DD to  $D_1D_1$ ) in demand curve has been possible not due to the change in price but rather due to other determinants of demand. This change in demand is called decrease in demand.

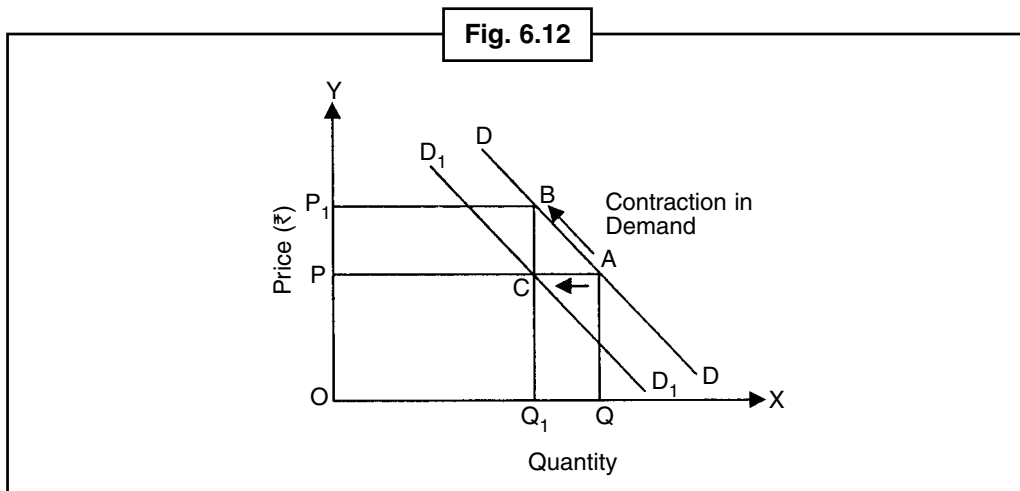

### 6.8 Elasticity of Demand

Demand of a commodity, specially depends upon its price, income of consumer and price of other related commodity. So it is known as elasticity of demand that on changing in price of a commodity

or income of consumer or price of other goods, how much changes occur in quantity of demand of that commodity. As per Dooley, "The elasticity of demand measures the responsiveness of the quantity demanded of a commodity to change in its price, price of other goods and changes in consumer's income." So elasticity of demand are of three types – 1. Price Elasticity of Demand, 2. Income Elasticity of Demand and 3. Cross Elasticity of Demand.

#### Elasticity of Demand Means

*Elasticity of demand, demands a numerical determination of the percentage change in quantity demanded, and the result is the ratio of the percentage change.*

## 6.9 Price Elasticity of Demand

The elasticity of demand measures the responsiveness of the quantity demanded of a commodity to change in its price, Ceteris Paribus. **It is equal to the ratio of the percentage change in quantity demanded to a percentage change in its price.** This measures that how much changes in its quantity demanded to change in its price. Elasticity of demand represents a ratio at which demand is contracted to increase in price and extended to decrease in price. There is found an inverse relation between quantity demanded and its price. So Elasticity of demand is represented by negative sign. According to Lipsey, "Because of the negative slope of the demand curve, the price and the quantity will always change in opposite directions. One change will be positive and the other will be negative, making the measured elasticity of demand negative." But according to tradition, negative sign has been left and price elasticity of demand is represented with numbers. For example, 15 % increase is responded in quantity demanded to 10% decrease in price of ice cream, and then elasticity of demand will be as follows:

$$E_d = \frac{(-)15\%}{(-)10\%} = 1.5$$

**Negative Sign** is too leaved because any **Ambiguity** do not arise. To say, this can be surprising that elasticity coefficient of (-) 4 will be more than -2, can be safe to this possible surprising. If we said only that multiplier of 4 represents more elasticity than multiplier of 2, so negative sign is generally not used before the value of elasticity of demand.

$$E_d = (-) \frac{\text{Percentage Change in Quantity Demanded}}{\text{Percentage Change in Price}}$$

Let's assume that demand extends to 20% as a result of 10% decrease in price. Then elasticity of demand will be

$$E_d = \frac{(-)20\%}{(-)10\%} = 2$$

It means that if quantity of demand changes with 2% due to the 1% change in price.

*Elasticity of Demand may be defined as the percentage change in the quantity demanded divided by the percentage change in the price.*

—Marshall

*Price elasticity of demand measures the responsiveness of the quantity demanded of a goods to the change in the price.*

—Boulding



Notes



*Task* Express your view about elasticity of demand.

### 6.10 Two Extreme Situations of Price Elasticity of Demand

Two Extreme situations of price relativity of demand are (1) Zero and (2) Infinity.

1. **Zero Price Elasticity of Demand:** Elasticity of demand becomes zero when no change in quantity demanded of goods to change in the price. It means no matter how much are brought in price, there will not be any contraction and extension in its quantity demanded. This situation is called Perfectly Inelastic Demand.

Zero Price Elasticity of Demand ( $E = 0$ )

In Fig. 6.13 a vertical straight line is presented which clears that no matter how much change will occur in price, demand OD of goods will remain stable. In this way, demand curve is called Perfectly Inelastic Demand Curve. Any extension or contraction is expressed by this demand curve.

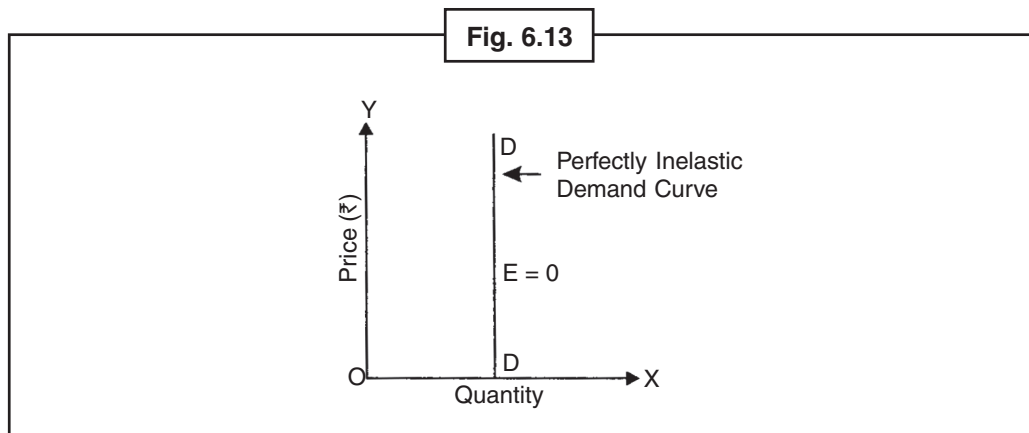

2. **Infinity Price Elasticity of Demand:** Elasticity of demand becomes infinity when quantity demanded changes infinitely with also very small change in price. Elasticity of demand becomes infinity when however much quantity of product of a firm is demanded at current prices, then entirely product of firm is not demanded.

Infinity price Elasticity of demand ( $E = \infty$ )

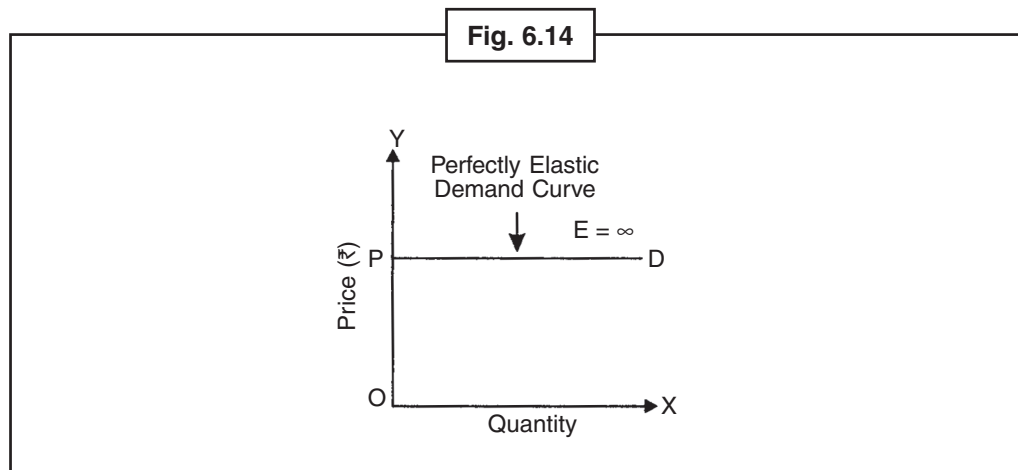

In Fig. 6.14, a Horizontal Straight Line is presented which clears that at price  $OP$  any amount of a commodity can be bought but not anymore quantity will be bought even if small rise from  $OP$  will occur. It can be said in other words that **there is infinity change from infinite demand to zero demand**. Demand curve of this type is called as **Perfectly Elastic Demand Curve**.

### 6.11 Normal Situations of Price Elasticity of Demand

Generally, price elasticity of demand can have the following situations:

1. **Elasticity of Demand = 1** (It is termed as Unitary Elastic Demand)
2. **Elasticity of Demand > 1** (It is termed as Greater than Unitary Elastic Demand). This price elasticity of demand is also known as the Unitary Elastic.
3. **Elasticity of Demand < 1** (It is termed as less than Unitary Elastic Demand). This is also known as less elastic demand. All the above situations of elasticity of demand can be cleared with the help of Figs. 6.15, 6.16 and 6.17.

### 6.12 Demand Curves Showing $E = 1$ , $E > 1$ and $E < 1$

Different situations of elasticity of demand is shown in the following Figs. 6.15, 6.16 and 6.17:

1. **Unitary Elastic Demand:** When the expenditure done on commodity remains stable on increase or decrease in price, then it is the Unitary Elastic Demand. The total expenditure is  $PQ$ . Here,  $P$  = price;  $Q$  = Demand. In Fig. 6.15,  $DD$  demand curve is showing Unitary Elastic Demand. It is clear that, when price is  $OP_1$  then total expenditure will be  $OQ_1MP_1$ . Opposite to it when price decreases to  $OP_2$  then total expenditure will be  $OQ_2NP_2$ .

$$\text{Area } OQ_1MP_1 = \text{Area } OQ_2NP_2$$

It means that total expenditure remains stable even after changing price of commodity. So elasticity of demand is unitary means  $E = 1$  (Unitary)

Notes

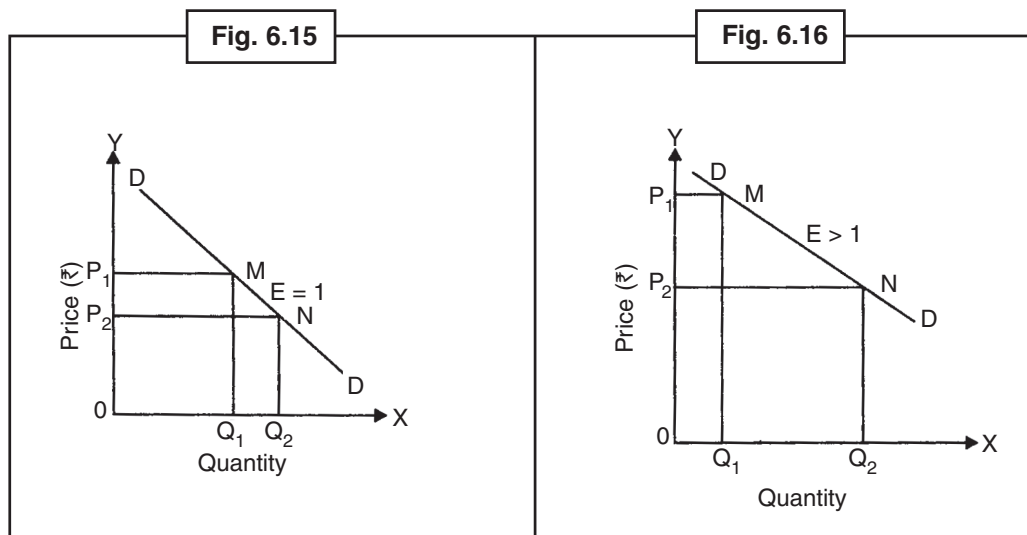

2. **Greater than Unitary Elastic Demand:** When the total expenditure increases on decreasing the price of commodity and decreases on increasing the price of commodity, then it is greater than Unitary Elastic Demand. In Fig. 6.16, DD demand curve is showing greater than unitary elastic demand. It is shown that when price is OP<sub>1</sub> then total expenditure will be OQ<sub>1</sub>MP<sub>1</sub>. Opposite to it when decreases to OP<sub>2</sub> then total expenditure will be OQ<sub>2</sub>NP<sub>2</sub>. Therefore,

$$\text{Area } OQ_2NP_2 > \text{Area } OQ_1MP_1$$

It means that total expenditure done has increased on decreasing the price of commodity. Therefore, elasticity of demand is greater than unitary or more elastic.

3. **Lesser than Unitary Elastic Demand E < 1:** Elastic Demand is lesser than unitary when expenditure done decreases on decreasing the price of commodity and increases on increasing the price of commodity. In Fig. 6.17, DD demand curve is showing lesser than unitary elastic demand. It shows that when price is OP<sub>1</sub> then total expenditure will be OQ<sub>1</sub>MP<sub>1</sub>. Opposite to it, when price is OP<sub>2</sub> then total expenditure will be OQ<sub>2</sub>NP<sub>2</sub>. Therefore,

$$\text{Area } OQ_2NP_2 < \text{Area } OQ_1MP_1$$

It means that total expenditure done has decreased on decreasing the price of commodity. Therefore elasticity of demand will be less than unitary (E < 1) or less elastic.

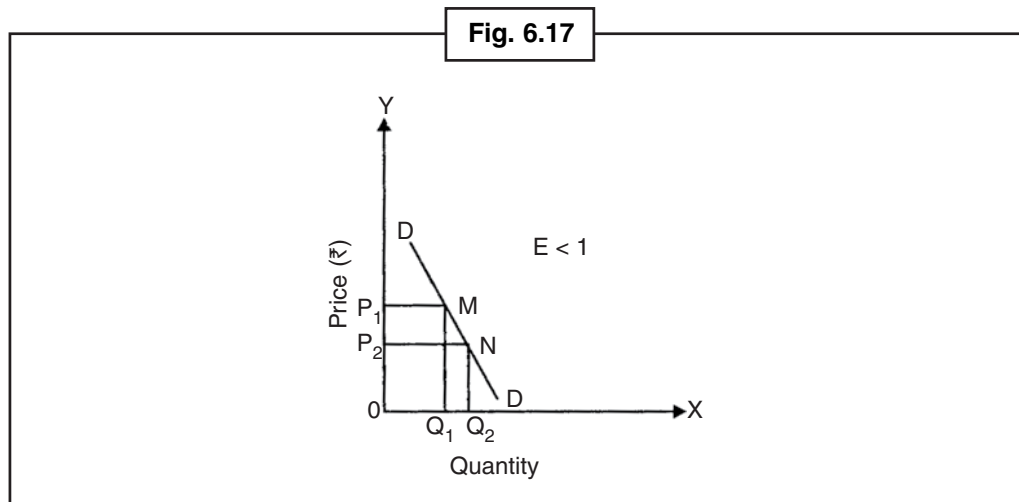

### 6.13 Measurement of Price Elasticity of Demand

It is come to know from measurement elasticity of demand, demand of any commodity is (i) Unitary or (ii) Greater than Unitary (iii) Lesser than Unitary. There are many methods of measurement of elasticity of demand –

1. Total Outlay or Total Expenditure Method
  2. Proportionate or Percentage Method
  3. Point Elasticity Method
  4. Arc Elasticity Method
  5. Revenue Method
- } Graphic Method

#### 1. Total Outlay or Total Expenditure Method

Total Expenditure Method of measurement of elasticity of demand was invented by Dr. Marshal. According to this method, it should know that total expenditure done in which direction on change in price of commodity for the measurement of elasticity of demand –

- (i) When there is no change in total expenditure on increase or decrease in the price of commodity then **elasticity of demand** will be equal to unitary ( $E_d = 1$ ).
- (ii) When total expenditure increases on decreasing the price of commodity and decreases on increasing the price of commodity, means total expenditure moves in opposite direction to the change in price then **elasticity of demand will be greater** than unitary ( $E_d > 1$ ).
- (iii) When total expenditure decreases on decreasing the price of commodity and increases on increasing the price of commodity, means total expenditure moves in that direction in which the price changes then **elasticity of demand will be less than unitary** ( $E_d < 1$ ).

Notes Measurement of Elasticity of Demand can be cleared by Table 5:

Table 5: Total Expenditure Method				
Price of Commodity (₹)	Purchased Quantity (Kg)	Total Expenditure (₹)	Change in total expenditure	Elasticity of Demand
2	4	8	Total expenditure does not change.	Unitary Elastic
4	2	8		
1	8	8		
2	4	8	When price increases, total expenditure decreases. When price decreases, total expenditure increases.	Greater than Unitary Elastic or Elastic
4	1	4		
1	10	10		
2	3	6	When price increases, total expenditure increases. When price decreases, total expenditure decreases.	Less than Unitary Elastic or Inelastic
4	2	8		
1	4	4		

Following information is known from Table 5–

- (i) **Unitary Elastic Demand:** We come to know from first part of table 5 that when price of commodity is ₹ 2 then total expenditure on commodity is ₹ 8. Opposite to it when price increases to ₹ 4 or decreases to ₹ 1, then also total expenditure remained ₹ 8. **In other words, total expenditure is not affected by changing price.**
- (ii) **Greater than Unitary Elasticity:** We come to know from second part of table 5 that when price of commodity is ₹ 2 then total expenditure on commodity is ₹ 8. If price increases to ₹ 4, then total expenditure decreases to ₹ 4 from ₹ 8 and when price decreases to ₹ 1 then total expenditure increases to ₹ 10. **In other words, total expenditure changes in the opposite direction on changing prices.**
- (iii) **Less than Unitary Elasticity:** We come to know from third part of table 5 that when price of commodity is ₹ 2 then total expenditure on commodity is ₹ 6. If price increases to ₹ 4, then total expenditure increases to ₹ 8. When price decreases to ₹ 1 then total expenditure decreases to ₹ 4. **In other words, total expenditure changes in the same direction on changing prices.**

Total Expenditure Method of measuring elasticity of demand can be cleared by Fig. 6.18. In this figure, total expenditure is shown on OX-axis and price is shown on OY-axis. **ST curve is total expenditure curve.** BC portion of ST curve represents the unitary elasticity. We come to know that when price is **OM**, then total expenditure is MC. When price increases to ON then total expenditure is NB (= MC) means remains the same as before. TB portion of ST curve representing greater than unitary elasticity. It

is come to know that when price rises from ON to OR then total expenditure decreases to RA from BN means the change occurs in opposite direction. SC portion of ST curve representing less than unitary elasticity. We come to know when price decreases from OM to OP then total expenditure decreases from MC to PD means changes in same direction.

Notes

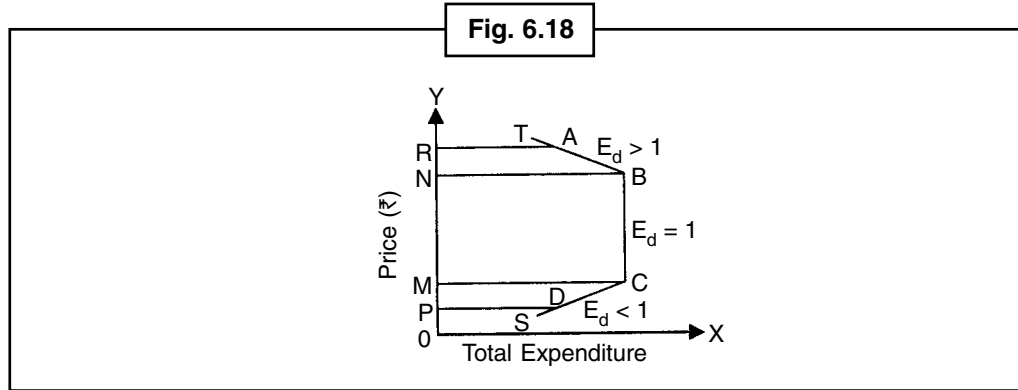

## 2. Proportionate or Percentage Method

The second method of measuring price elasticity of demand is termed as percentage or proportionate method. According to this method, for assessment of price elasticity of demand, percentage change in demand is divided by percentage change in price. Its formula is written as follows –

$$E_d = \frac{\text{Change Per cent in Quantity Demanded of X-Commodity}}{\text{Change Percentage in Price of Commodity}}$$

$$E_d = \frac{\frac{\text{Change in Demanded Quantity}}{\text{Initial Price}}}{\frac{\text{Change in Price}}{\text{Initial Demand}}} \times 100$$

$$\begin{aligned} & \frac{(Q_1 - Q)}{Q} \times 100 \div \frac{\Delta P}{P} \times 100 \\ & = (-) \frac{Q}{\frac{(P_1 - P)}{P} \times 100} = (-) \frac{Q}{\frac{\Delta P}{P} \times 100} \end{aligned}$$

$$E_d = (-) \frac{\Delta Q}{Q} \div \frac{\Delta P}{P} = (-) \frac{\Delta Q}{Q} \times \frac{P}{\Delta P}$$

$$E_d = (-) \frac{P}{Q} \times \frac{\Delta Q}{\Delta P}$$

Here Q = Initial demanded quantity of commodity; Q<sub>1</sub> = changed demanded quantity; P = Initial price of commodity; P<sub>1</sub> = Changed price; ΔQ = ΔQ<sub>1</sub> - Q (change in demanded quantity); ΔP = P<sub>1</sub> - P = Change in price; Δ = Delta (this sign represents change).

Percentage change in quantity of X-commodity is defined as 100 times change in X-commodity means 100 ΔX is divided by X. For example, if quantity increases to 15 from 10 then we will say that ΔX = 15 - 10 = 5 and percentage increase in X =  $\frac{\Delta X}{X} \times 100 = \frac{5}{10} \times 100 = \frac{500}{10} = 50\%$ , similarly percentage change in price is represented by  $\frac{\Delta P}{P} \times 100$ .

Notes

**Illustration 1.**

Assume the percentage change in quantity of demand with the decrease in price of commodity is 10%. Let the elasticity of demand = (-) 2.5.

**Solution:** Let percentage change in demand be X.

**Remember**

*Percentage method is used in the condition in which change in price and then change in demand is very less.*

$$\text{Elasticity of Demand} = (-) \frac{\text{Percentage Change in Demanded Quantity}}{\text{Percentage Change in Price}}$$

$$2.5 = (-) \frac{X}{10\%}$$

$$X = 2.5 \times 10\% = 25\%$$

**Answer:** Percentage Change in demanded quantity will be 25%

**3. Point Elasticity Method**

Elasticity of demand on single point of demand curve is called as Point Elasticity.

According to Leftwich, "Elasticity computed at a single point on the curve for infinitely small change in price is point elasticity."

Price elasticity on simple demand curve depends on the point on which it is measured or the slope of demand curve. Therefore, price elasticity will vary on different points of a demand curve. So the elasticity of demand is measured individually on individual point of demand curve.

**Linear Demand Curve:** In Fig. 6.19, MN demand curve is a simple curve. Elasticity of demand at 'A' point of demand curve will be equal to  $\frac{AN}{AM}$ , which can be calculated by the following method, as we know that

$$E_d = (-) \frac{P}{Q} \times \frac{\Delta Q}{\Delta P}$$

It is known by Fig. 6.19 that,

$$P = OP (= AQ); Q = OQ (= AP);$$

$$\Delta P = PP_1 (= AB); \Delta Q = QQ_1 (= BC);$$

$$\therefore E_d = \frac{AQ}{AP} \times \frac{BC}{AB} \tag{... (i)}$$

Because,  $\Delta ABC$  and  $\Delta AQN$  are similar triangles so ratio of their sides will be equal, means  $\frac{BC}{AB} = \frac{QN}{AQ}$

On placing  $\frac{QN}{AQ}$  on the place of  $\frac{BC}{AB}$  in equation (i), we determine,

$$E_d = \frac{AQ}{AP} \times \frac{QN}{AQ} = \frac{QN}{AP} = \frac{QN}{OQ} \text{ (AP = OQ)}$$

Because  $\Delta AQN$  and  $\Delta MPA$  are similar triangles so ratio of their sides will be equal,

$$E_d = \frac{QN}{OQ} = \frac{QN}{AP} = \frac{AN}{AM} = \frac{\text{Lower Segment}}{\text{Upper Segment}}$$

Price elasticity is determined on different points of simple curve by Fig. 6.19.

Notes

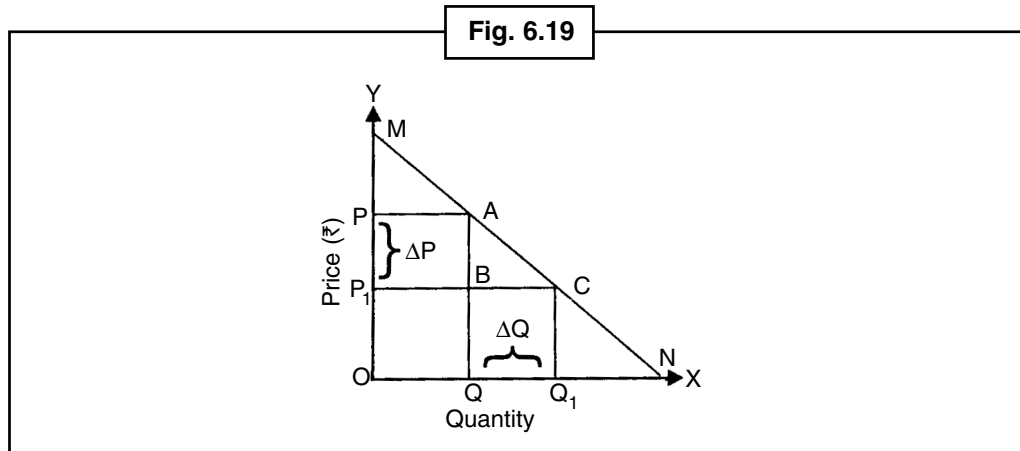

- (i) **Point P** is located in the middle of demand curve MN so PN (lower segment) and PM (upper segment) will be equal. Therefore,

$$E_d = \frac{PN}{PM} = 1 \text{ (Unity) means elasticity of demand on point P will be unity.}$$

#### 4. Arc Elasticity Method

Arc Elasticity Price is a measurement of the average **responsiveness** of change, which shows the portion between two points on the demand curve. **An arc is the portion between two points on the demand curve.** In fig. 6.20, the portion between A and C points is an arc on demand curve DD. The elasticity which is to be found by using midpoint or average price and quantity, it is called as Arc Price Elasticity.

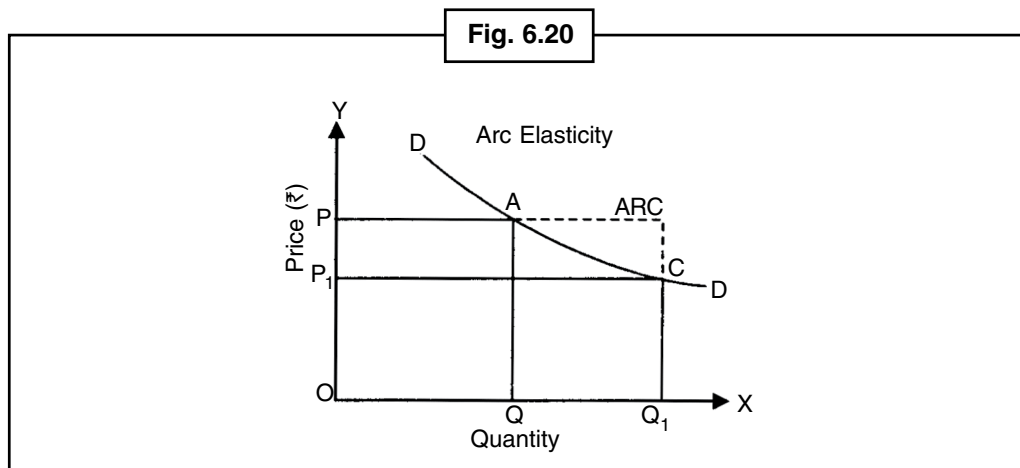

*Arc elasticity is the elasticity at the midpoint of an arc of a demand curve.*

–Wastson.

*Arc elasticity is a measure of the average elasticity between two points on the demand.*

–Ferguson.



Notes

Formula

According to price elasticity formula –

$$E_d = \frac{P}{Q} \times \frac{\Delta Q}{\Delta P}$$

It is clear that, change brought in quantity  $\Delta Q = Q_1 - Q$  and change in price  $\Delta P = P_1 - P$ . But what are the costs of P and Q? Because there are different costs of P and Q on the different points of AC arc, so it is not necessary to use the fixed value of one of these. According to law, average of P and Q is used so that:

$$Q = \frac{(Q_1 + Q)}{2} \text{ and } P = \frac{(P_1 + P)}{2}$$

Therefore, arc price elasticity of demand is determined by the help of following formula –

$$E_d = \frac{\text{Change in Quantity}}{\frac{1}{2} \text{ Sum of Quantities}} + \frac{\text{Change in Price}}{\frac{1}{2} \text{ Sum of Price}}$$

$$E_d = (-) \frac{\frac{\Delta Q}{\frac{1}{2} (Q_1 + Q)}}{\frac{\Delta P}{\frac{1}{2} (P_1 + P)}} = (-) \frac{\Delta Q}{\frac{1}{2} (Q_1 + Q)} \times \frac{\frac{1}{2} (P_1 + P)}{\Delta P}$$

or

$$E_d = (-) \frac{Q_1 - Q}{\frac{1}{2} (Q_1 + Q)} \times \frac{\frac{1}{2} (P_1 + P)}{P_1 - P} = (-) \frac{Q_1 - Q}{Q_1 + Q} \times \frac{P_1 + P}{P_1 - P}$$

Here, Q = Initial Demand; Q<sub>1</sub> = New Demand; P= Initial Price; P<sub>1</sub> = New price

According to Arc Elasticity Method, if proportion of price of a commodity increases or decreases and as a result of that there is contraction or relaxation in that proportion in the demand of commodity also, and then the elasticity of demand will be the same. But if percentage method is used, then elasticity of demand will be different in above condition. In first, this will be more than the unit (6) or elastic and in second, this will be less than the unit ( $\frac{3}{4}$ ) or inelastic.

**Therefore, arc elasticity method is more actual and dependent method in comparison to percentage elasticity method.**

There is also difference between arc elasticity of demand and point elasticity. Arc elasticity is the average cost of elasticity on a special portion of demand curve while point elasticity is the the cost of elasticity on a special point of demand curve. According to **Baumol**, **“Point elasticity of demand is the corresponding concept, for each point on the demand curve. But at any such point there is no change in price ( $\Delta P = 0$ ) or in quantity ( $\Delta Q = 0$ ). We, therefore, take point elasticity to be the limit of the arc elasticity figure as the arc is made smaller and smaller.”**

### 5. Revenue Method

Revenue method is the fifth method of determining the elasticity of demand. Whatever the selling price is earned by the factory of its production that is called **revenue** income. Suppose a company earns ₹ 50 by selling 10 m of cloth. So, this ₹ 50 will be called as total revenue of the factory. If **total revenue** is divided by the quantity of units of production, then the quotient will be known as Average Revenue or Per Unit Price. Average Revenue of above factory will be  $\frac{50}{10} = ₹ 5$  per metre. Therefore, average revenue and price are the synonyms. The difference comes in total revenue by selling a more units of any commodity that is called the Marginal Revenues. If the factory earns ₹ 54 by selling 11 metre cloth, then it means the marginal revenue of 11th metre cloth will be ₹ 54 - ₹ 50 = ₹ 4. An average revenue curve of

a factory is also known as demand curve. The elasticity of demand by Average revenue and Marginal revenue can be determined by the following formula –  $E_d = \frac{A}{A - M}$ . (Here,  $E_d$  = Price elasticity of demand, A = Average Revenue; M = Marginal Revenue).

This formula of Elasticity of demand can be cleared with the help of Fig. 6.21. In this figure, revenue on OY-axis and quantity of commodity on OX-axis are shown. AB is average revenue (AR) or demand curve and AN is marginal revenue (MR) curve. Elasticity of demand on 'P' point of Demand curve (average revenue) can be determined with the help of following formula –

$$E_d = \frac{\text{Lower Part}}{\text{Upper Part}} = \frac{PB}{PA}$$

$\Delta PMB$  and  $\Delta AEP$  are congruent triangles, so the ratio of their sides are equal.

$$E_d = \frac{PB}{PA} = \frac{PM}{AE} \quad \dots (1)$$

$\Delta AET$  and  $\Delta TPL$  are congruent triangles, so  $PL = AE$ .

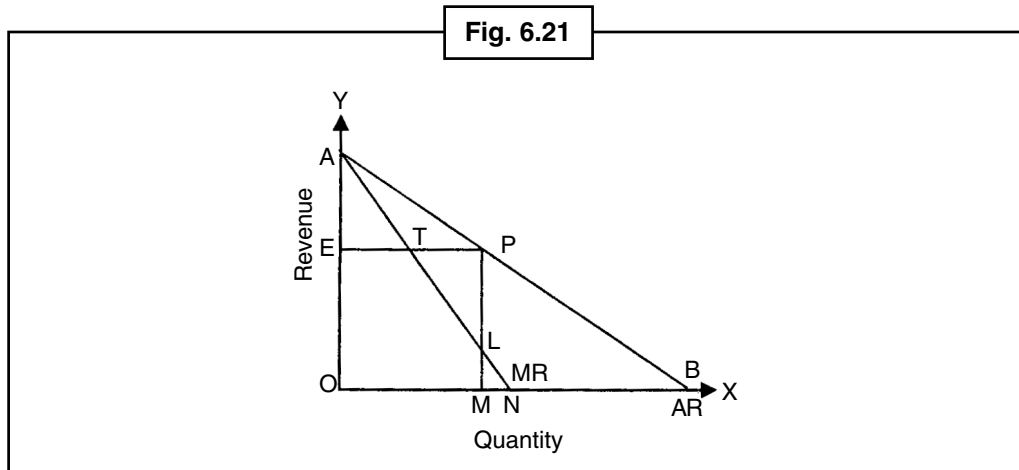

Writing PL in place of AE in equation (1)

$$E_d = \frac{PM}{PL}$$

because  $PL = PM - LM$

therefore  $E_d = \frac{PM}{PM - LM}$

here  $PM = AR$  and  $LM = MR$

$$\begin{aligned} \text{so } E_d &= \frac{PM}{PM - LM} = \frac{AR}{AR - MR} \text{ or } \frac{A}{A - M} \\ &= \frac{\text{Average Revenue}}{\text{Average Revenue} - \text{Marginal Revenue}} \end{aligned}$$

If the cost of  $E_d$  is same by using the above formula, then elasticity of demand will be unity. If it is more than one then price elasticity of demand will be more than the unity or elastic and if it is less than one then price elasticity of demand will be less than the unity or inelastic.

Notes

Self Assessment

State whether the following statements are True/False:

8. An individual demand curve is that curve which shows the quantity of demand by consumer on different prices of commodity.
9. Market demand curve is horizontal summation of individual curves.
10. When the demand decreases on decreasing the price of any commodity while remaining other things are same is known as extension of demand.
11. When the demand increases on increasing the price of any commodity while remaining other things are same is known as contraction of demand.
12. By change in price of a commodity, consumer's revenue and price in related commodity, the measurement of upcoming change in quantity of demand will be known as elasticity of demand.

**6.14 Some Theorems Related to Elasticity of Demand**

**Theorem 1.**

**The Elasticity of Demand on a straight line demand curve varies downward from zero to infinity**

The value of elasticity of demand is zero at that point on which the demand curve touches the OX-axis and infinite on that point on which curve touches the OY-axis. Therefore, on increase in price, elasticity of demand also increases on a simple demand curve. This statement is cleared by the Fig. 6.22.

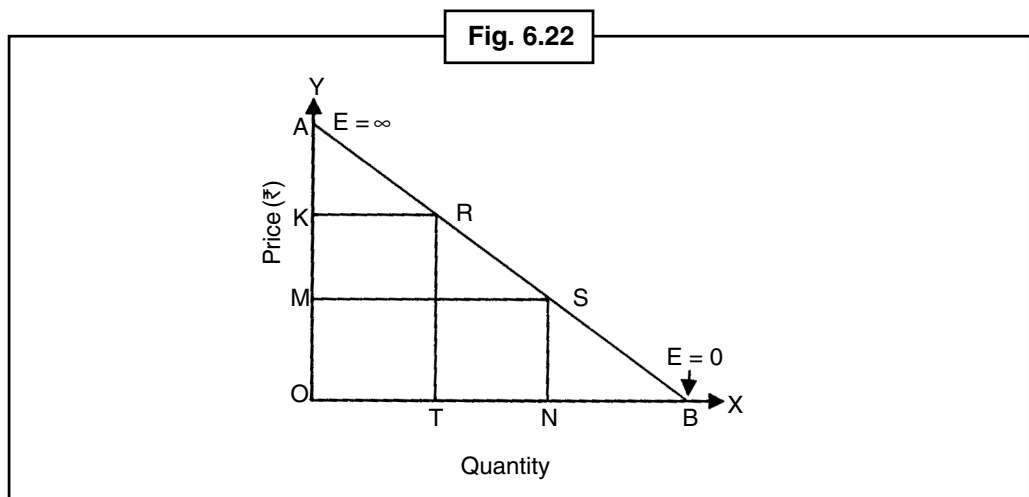

Price elasticity of demand is measured as follows –

$$E_d = - \frac{\text{Per cent Change in Demanded Quantity of X-commodity}}{\text{Per cent Change in Price of X-commodity}}$$

Above equation can be written in the following way –

$$E_d = \frac{P}{Q} \times \left( \frac{1}{\text{Slope of Demand Curve}} \right)$$

Because slope of a simple demand curve is equal to  $\frac{\Delta P}{\Delta Q}$ . We know that the slope of a simple demand curve is equal of its all the points that is why the reciprocal  $\left( \frac{1}{\text{Slope of Demand Curve}} \right)$  of slope will also

remain the same. The comparison of elasticity of demand on different points of the demand curve AB can be done by the comparison of  $\frac{P}{Q}$ .

- (i) this ratio on point A =  $\frac{OP}{Zero} = \infty$  (Infinity)
- (ii) this ratio on point B =  $\frac{Zero}{OB} = 0$  (Zero)
- (iii) As we move down to point B from point A we come to know that ratio of  $\frac{P}{Q}$  decreases from  $\infty$  (infinity) to 0 (zero). It is clear from the figure that this ratio at point R is equal to  $\frac{OK}{OT}$  and is equal to  $\frac{OM}{ON}$  at point S. Value of  $\frac{OK}{OT}$  is definitely more in comparison to  $\frac{OM}{ON}$ . Therefore, it is proved that as we move down on demand curve, price of commodity goes on decreasing and value of related elasticity of demand goes on decreasing.

### 6.15 Factors Determining the Price Elasticity of Demand

As we see in actual life that elasticity of demand of some commodities is unity, elasticity of demand of some commodities is more than the unit or **Elastic** and elasticity of demand for some commodities is less than the unity or **Inelastic**. The reason behind this is that elasticity of demand is affected by many factors. The main factors of determining the elasticity of demand are as follows:

1. **Nature of the Commodity:** In economics, classification of commodities is mainly done in three categories; they are (i) **Necessaries**, (ii) **Comforts** and (iii) **Luxuries**. Generally, it has been seen that the demand of mandatory commodities like salt, kerosene oil, match boxes etc. is less than unity or **Inelastic**. The reason is that a customer buys a limited quantity of these commodities, whether price of these commodities increases or decreases. So, the change in their prices does not affect their demand as much. Opposite to it the demand of luxuries like air conditioner, expensive furniture etc. is more than the unity or **Elastic**. The reason is that the changes in their prices affect very much their demand. Price elasticity of comfortable things like transistor, cooler, fan etc. is equal to unity or near to it.
2. **Availability of Substitutes:** The elasticity of demand will be more as much as the availability of substitutes of the commodity. The substitutes of commodity like substitute of tea; coffee, substitute of pen; ball-pen, substitute of milkshake; *lassi*, substitute of sandals; sleeper etc. are available on worth price, so demands of these commodity is elastic. The reason is that if price of any commodity decreased in the comparison of its substitute then people will purchase it in more quantity. For example, if coffee costs cheap in comparison of tea then demand of coffee will increase more, and demand of tea will decrease more. The demand of the commodities which do not have their substitutes like cigarette, wine etc. is inelastic.
3. **Goods with Different Uses: The elasticity of demand is more elastic as much as the uses of a commodity.** The elasticity of demand is elastic of those goods which are included in different uses. For example, the electricity has different uses. It is used in bulb, heater, heating iron etc. If price of electricity will increase then it will be used in the important work like bulb for lightning only. In this way, demand of electricity will decrease by more in comparison of upcoming increment in price.
4. **Postponement of Demand: The demand of those commodities can be postponed these demands are elastic.** For example, if demand of building house can be postponed then the demand of constituents of house like bricks, sand, cement, limestone etc. will be elastic. Opposite to it, demands of those commodities cannot be postponed for future, like food on hunger and liquids on thirst, and then the demand is inelastic.

Notes

5. **Income of the Consumer:** Those people having their income very much or very less, their demands are generally inelastic. The reason is that it does not affect demand by them as much by increase or decrease in price. Opposite to it, the demand of medium class people is elastic. On increment in price of the commodities demanded by these people, their demands become comparatively less.
6. **Habit of the Consumer:** The demand of those commodities is inelastic for which people get addicted like cigarette, coffee etc. The reason is that on increment in the prices of these commodities also the demands of customer do not decrease.
7. **Proportion of Income Spent on a Commodity:** The ratio of income spent on a commodity is directly proportional to the elasticity of demand. Those commodities on which customer spends very less ratio of his income like newspaper, toothpaste, shoe polish, etc., the demand of those commodities is inelastic. The demand decreases on increasing the price of these commodities. Opposite to it, the demand of those commodities on which the customer spends more of its income like garments, best food, desert cooler, fruits etc. is elastic. The demand decreases on increasing their prices because customer starts finding their substitute commodity.
8. **Price Level:** The demand of very expensive and very cheap commodities is inelastic. The demand of more expensive commodities like diamond, jewellery, expensive carpets etc. is inelastic. The demand changes by little on changing the prices of these commodities. In this way, the demand of those commodities which have very less price like matchbox, postcard, cheaper vegetables etc. is also inelastic. The demand does not affect as much on change in price of these commodities. Opposite to it, the demand of those commodities which are medium price goods or those which are neither very cheap nor very expensive is elastic. The demand is comparatively high on decrease in price of these commodities.
9. **Time:** The demand is more elastic in long-term in comparison to short-term. As the duration of time increases the customer gets more time to adjust with the new prices, so the demand will be more elastic. If customer gets less time to adjust with the new prices then the demand will be more inelastic. Therefore, demand of any commodity is inelastic in short-term and elastic in long-term.
10. **Complementary Goods:** The goods which demand as in joint or adjustable are generally inelastic like car and petrol, pen and ink, camera and film. If the price of petrol increases, the demand will be the same if the demand of Cars would remain same.

*The availability of commodities and the level of goods are the two main things which responsible for demand of elasticity.*

### 6.16 Income Elasticity of Demand

Other things mean, on the stability of the price of specific commodity, prices of related commodities, choice of the customer etc., the ratio of the percentage change in demand of specific commodity on the percentage change in income of a customer is known as income elasticity of demand.

*"Income elasticity of demand means the ratio of the percentage change in quantity demanded to percentage change in income."*

– Watson

*"The responsiveness of demand to change in income is termed as income elasticity of demand."*

– Richard G. Lipsey

### 6.17 Measurement of Income Elasticity of Demand

Income elasticity of demand can be measured by the following formula –

$$E_y = \frac{\text{Proportionate or Percentage Change in Quantity Demanded}}{\text{Proportionate or Percentage Change in Income}}$$

$$E_y = \frac{\frac{\Delta Q}{Q}}{\frac{\Delta Y}{Y}} = \frac{\Delta Q}{\Delta Y} \times \frac{Y}{Q} = \frac{Y}{Q} \times \frac{\Delta Q}{\Delta Y}$$

$$E_y = \frac{Y}{Q} \times \frac{\Delta Q}{\Delta Y}$$

Here  $E_y$  = Income Elasticity of Demand;  $Q$  = Initial Income;  $Y$  = Initial Income;  $\Delta Q$  = Changes in the Volume of Demand;  $\Delta Y$  = Changes in Income.

### Illustration

When your monthly income ( $Y$ ) is ₹ 300 then you buy 10 ice creams ( $Q$ ), if your monthly income ( $Y_1$ ) increases to ₹ 600 then your demand increases to 30 ice creams. Find income Elasticity of Demand of Ice creams.

### Solution:

Income Elasticity of Demand can be measured by the help of following equation:

$$E_y = \frac{Y}{Q} \times \frac{\Delta Q}{\Delta Y}$$

Here  $Y = ₹ 300$ ;  $Y_1 = ₹ 600$ ;  $\Delta Y = Y_1 - Y = ₹ 600 - ₹ 300 = ₹ 300$ ;  $Q = 10$  Units of Ice cream;  $Q_1 = 30$  Units of Ice cream;  $\Delta Q = Q_1 - Q = 30$  Units - 10 Units = 20 Units of Ice cream

$$E_y = \frac{300}{10} \times \frac{20}{300} = 2 \text{ (more than unity)}$$

## 6.18 Degrees of Income Elasticity of Demand

There are three types of income Elasticity of Demand:

- 1. Positive Income Elasticity of Demand:** Income Elasticity of Demand of any object is positive on that condition when increase in income of consumer results in increases in demand of objects and decrease in demand of objects occurs with decrease in income. Income Elasticity of Demand for normal goods is positive.

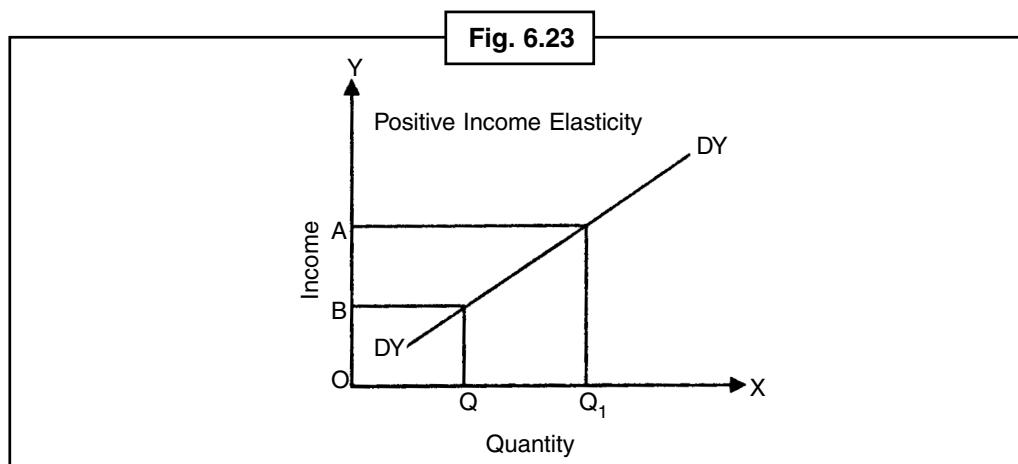

**Notes**

It can be described with the help of Fig. 6.23. Quality of demands of an object is shown on OX-axis and income of consumer is shown on OY-axis. Curve DYDY shows positive income elasticity of demand. Slope of this curve is inclined from left to right which indicates that on increasing income demand increases and decreases on decreasing income.

*Income elasticity of demand of normal objects is positive while object of below normal income elasticity of demand is negative.*

There can be three kind of positive income elasticity of demand –

- (i) **Unitary Income Elasticity of Demand:** Positive income elasticity of demand is unitary on that situation when changes in percentage of income, same percentage changes in the quantity of demand. Suppose that if income increases in percentage and also 100 percentage increase in demand then

$$E_y = \frac{100\%}{100\%} = 1 \text{ units (Unitary)}$$

- (ii) **Less than Unitary Income Elasticity of Demand or Income Inelastic Demand:** The less unitary income elasticity of demand happens when the percentage changes in demand is less than percentage changes in income. If income raises by 100% but demand increase by only 50 and then

$$E_y = \frac{50\%}{100\%} = \text{Less than } \frac{1}{2} \text{ units (Less than unitary)}$$

- (iii) **More than Unitary Income Elasticity of Demand or Income Elastic Demand:** This happens when the percentage changes in demand is greater than percentage changes in income. For example, if income rises by 100% and demand raises by 200% then

$$E_y = \frac{200\%}{100\%} = \text{more than 2 units (Greater than Unitary)}$$

- 2. **Negative Income Elasticity of Demand:** The Income Elasticity of Demand is negative when the income of consumer increases but the demand of product decreases and vice versa. This mainly happens for inferior goods. For example, rough cloth, rough goods, etc. is the symbol of negative income elasticity of demand. In Fig. 6.24 DYDY demand curve is representing the negative income elasticity of demand. Slope of this is decline from right to left. This means that if income is ₹ 10 then demand of objects is 4 units when income increases ₹ 20 then its demand reduced to 2 units.

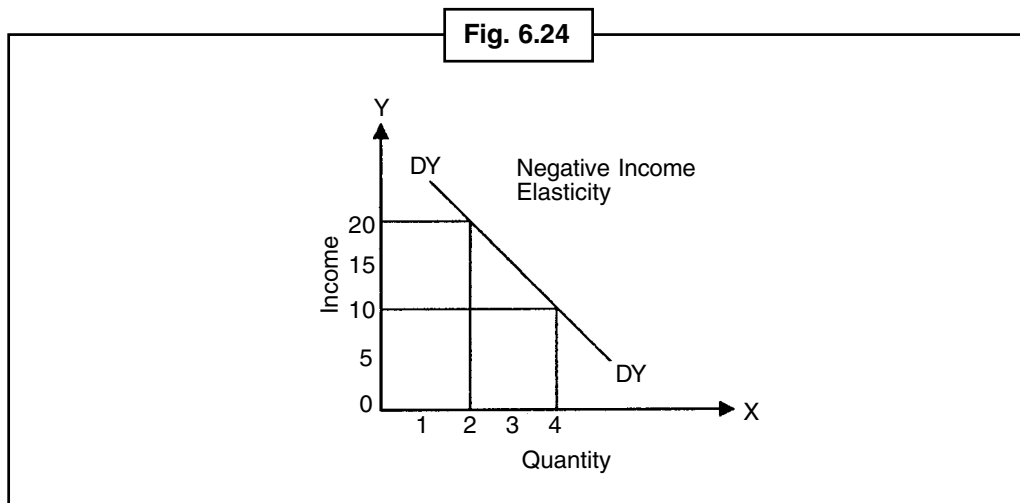

- 3. **Zero income Elasticity of Demand:** Income Elasticity of demand of any object become zero at that time when changes in income of consumer of that object remain unchanged in demand of that object.

This is clarified in Fig. 6.25. In this figure DYDY curve, indicates Zero income elasticity. This curve is parallel to OY- axis. It indicates that if income increases from ₹ 10 to ₹ 20 then demand of that object remains 4 units. Essential needs such as kerosene, salt etc. have zero income elasticity of demand.

Notes

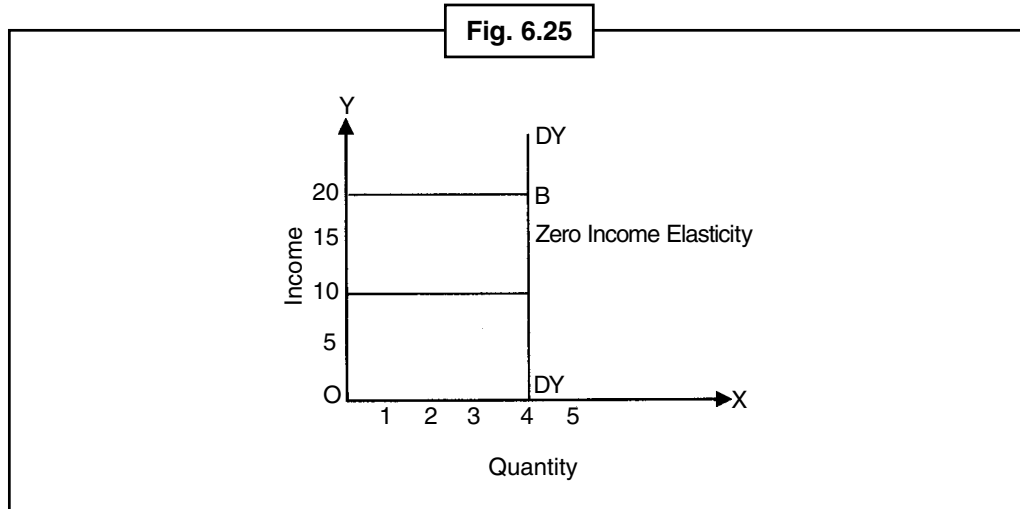

### 6.19 Cross Elasticity of Demand

The changes in quantity of demand and price of any two goods related to each other change in price of a object causes the change in demand in quantity of other objects. For example, change in price of tea changes the demand of coffee. The corresponding relations of quantity of demand of an object and change in price of other objects can be measured by cross elasticity of demand. **Price of object X cross elasticity of demand change in proportional demand of object Y measurement change in propositional ratio.**

*“The cross elasticity of demand is the proportional change in the quantity demanded of goods-X divided by the proportional change in the price of the related goods Y”.*

—Ferguson

*“The Cross elasticity of demand is a measure of the responsiveness of purchases of goods-X to change in the price of goods-Y”.*

—Leibhafasky

### 6.20 Measurement of Cross Elasticity of Demand

Cross Elasticity of Demand can be measured by the following equation—

$$E_c = \frac{\text{Proportionate or percentage change in Quantity demanded of Goods X}}{\text{Proportionate or percentage change in the price of Goods Y}}$$

$$= \frac{\frac{\text{Change in Quantity Demanded of X}}{\text{Original Quantity Demanded of Y}} \times 100}{\frac{\text{Change in Price of Y}}{\text{Original Price of Y}} \times 100}$$

$$= \frac{\frac{\Delta Q_x}{Q_x}}{\frac{\Delta P_y}{P_y}} = \frac{\Delta Q_x}{Q_x} \times \frac{P_y}{\Delta P_y}$$



Notes

$$E_c = P_y / Q_x \times \Delta Q_x / \Delta P_y$$

Here  $E_c$  = Cross Elasticity of Demand;  $P_y$  = Y Initial Price of Goods;  $\Delta P_y$  = Y Change in Price of Goods;  $Q_x$  = X Initial Quantity of Goods;  $\Delta Q_x$  = X Change in Quantity of Demand of Goods

### 6.21 Nature and Degrees of Cross Elasticity of Demand

- (i) **Positive:** For **Substitutes** cross elasticity of demand is positive. In other words, when object substitutes to each other then in this situation the percentage increase in price of an object will increase in demand of other objects, for example, increase in price of coffee, demand of tea will increase because both are substitutes.

#### Illustration

Suppose price of coffee is 50 paise per cup, demand of tea is 50 cups. If the price increases to 70 paise per cup then demand of tea rises up to 100 cups. Therefore, cross elasticity of demand of tea is assumed on the basis of following equation—

$$E_c = \frac{P_y}{Q_x} \times \frac{\Delta Q_x}{\Delta P_y}$$

$$Q_x = 50 \text{ cups}; Q_{x_1} = 100 \text{ cups}; \Delta Q_x = 100 \text{ cups} - 50 \text{ cups} = 50 \text{ cups}$$

$$P_y = 50 \text{ paise}; P_{y_1} = 70 \text{ paise}; \Delta P_y = 70 \text{ paise} - 50 \text{ paise} = 20 \text{ paise}$$

$$E_c = \frac{50}{50} \times \frac{50}{20} = \frac{5}{2} = 2.5 (E_c > 1)$$

Therefore, cross Elasticity of demand for tea is more than substitutes i.e., cross elasticity of demand or tea and coffee can be clearly shown in Fig. 6.26. In this figure on OX-axis quantity of tea and on OY-axis price of coffee are shown. When price of coffee is OB then demand of tea is OQ cup. When the price of coffee increased to OA then demand of tea increased to OQ<sub>1</sub>. DCDC curve indicates demand of tea on different quantities on different prices of coffee. This curve is lined from left to right. This proves that on increase of price of coffee demand of tea increases and decrease in price of coffee demand of tea decreases.

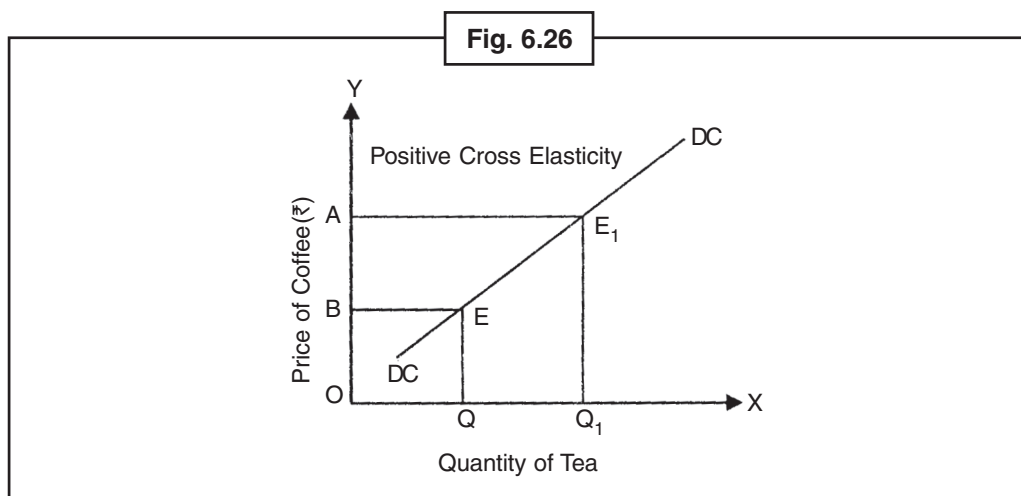

Fig. 6.26

- (ii) **Negative:** Cross Elasticity of demand for complementary goods is negative. Those demands which are complimentary to each other or those whose demand are joint demands with proportional increase in price of any object then propositional demand for others decreases. In this condition cross elasticity of demand is negative. Thus, in this situation before the number of cross elasticity of demand the sign of Minus (–) is added.

### Illustration

Bread and butter is complementary. When the price of bread is 80 paise then demand of butter is 10 kg. If the price of bread increases to ₹ 1.20 then demand of butter decreases to 5 Kg. Find cross elasticity of demand of butter.

Cross elasticity of demand of butter can be solved in the following equation

$$E_c = \frac{P_y}{Q_x} \times \frac{\Delta Q_x}{\Delta P_y}$$

$$P_y = 80 \text{ paise}; P_{y1} = 120 \text{ paise};$$

$$\Delta P_y = 120 \text{ paise} - 80 \text{ paise} = 40 \text{ paise}$$

$$Q_x = 10 \text{ kg}; Q_{x1} = 5 \text{ kg}$$

$$\Delta Q_x = 5 \text{ kg} - 10 \text{ kg} = -5 \text{ kg}$$

$$E_c = \frac{80}{10} \times \frac{-5}{40} = -1$$

(Here  $x$  is used for butter and  $y$  is used for bread)

Negative cross Elasticity of Demand can be clarified in Fig. 6.27. In this figure on Ox-axis indicates quantity of butter and OY-axis shows price of bread. DCDC line indicates cross Elasticity of Demand. Slope of this line declines from left to right which proves that on increasing price of bread, decrease demand of butter we know from point E and  $E_1$  that when OP is the price of bread then demand of butter is OQ and when price of bread increases OP<sub>1</sub>, then demand of butter decreases to OQ<sub>1</sub>.

- (iii) **Zero cross Elasticity of Demand:** Cross Elasticity of Demand becomes Zero when there is no relation between them, for example, increase in price of wheat demand would not any effect on book, therefore cross elasticity of demand will be Zero.

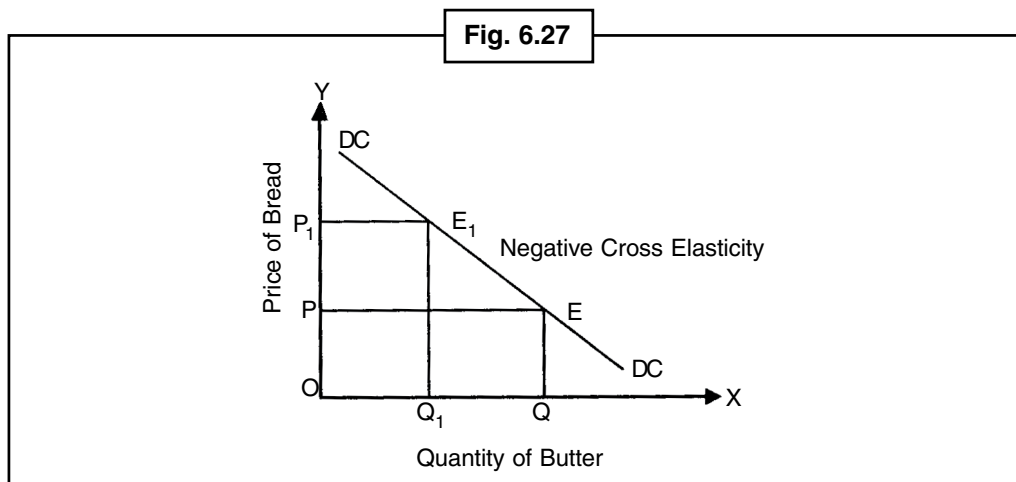

Notes

<b>Elasticity at a Glance</b>		
<i>Kinds</i>	<i>Numerical Measure</i>	<i>Description</i>
<b>(A) Price Elasticity of Demand</b>		
(1) Total Inelasticity	Zero ( $E_d = 0$ )	There is no change in Quantity of Demand after change in price
(2) Inelasticity or less than one	More than Zero but Less than Unit ( $0 < E_d < 1$ )	Proportional change in Quantity of Demand less proportional change in price
(3) Unit Elasticity	One $E_d = 1$	Proportional change in Quantity equal to proportional change
(4) Elasticity or more than Unit	More than One but less than Infinity ( $1 < E_d < \infty$ )	Proportional change in Quantity of Demand is more in proportional change
(5) Total Elasticity	Infinity ( $E_d = \infty$ )	Buy any Quantity on a constant price but nothing on high price
<b>(B) Income Elasticity of Demand</b>		
(1) Normal Goods	Positive	Quantity of Demand increases after increase in income
(a) Unit	One ( $E_y = 1$ )	Equal to change in percentage income percentage change in Quantity of Demand
(b) Less than Unit or Inelasticity	Less than one ( $E_y < 1$ )	Low change in percentage in quantity of demand in respect of change in percentage income
(c) More than one Elasticity	More than one ( $E_y > 1$ )	More percentage change in demand quantities in respect of income of percentage change
(2) Inferior goods	Negative	Demand Quantity is less after increase in income
<b>(C) Cross Elasticity of Demand</b>		
(1) Substitutes	Positive	After increase in price of Substitutes increases Quantity of Demand in related object
(2) Complementary	Negative	Increase in price of complementary decreases quantity of related objects

## 6.22 Importance of Price Elasticity of Demand

Following are the theoretical and practical importance of price Elasticity of Demand –

1. **Determination of price Under Monopoly:** Monopolist can alert on Elasticity of Demand of this object If –
  - (i) Demand is elastic then Monopolist will keep low price, sell will increase on keeping low price and total income will be maximum.
  - (ii) If demand is non-elastic then Monopolist will keep price high. With the increase in price sale of that object will be minimum but total revenue got from it will be high.
2. **Price Discrimination:** When Monopolist sells to different buyers in different prices, then this situation is called Price Discrimination. Monopolist can initiate the policy on price discrimination when elasticity of demand of any objects is different for different uses for different consumers. He will take more price from consumer for these objects whose demand are non-elastic and take less price from them whose demand of that object is elastic. For example, demand of electricity for a person is non-elastic so electric supplier takes more price for electricity for house consumer. In opposition of this, demand of electric for a industry is elasticity. If price of electric is high then industry can use oil, diesel or coal for their machines in place of electric. So electric supplier/ Board takes low price from industry.
3. **Price Determination of Joint Supply:** Joint Supply objects are those whose production is done simultaneously, i.e., cotton and binola, oil and khal etc. To determine price of these objects, elasticity of demand is kept in mind. For example, if demand of cotton is non-elastic and in respect of it demand of binola is elastic then price of cotton will determine high and price of binola will be less.
4. **Taxation Policy:** Finance minister keeps in mind Elasticity of Demand to regular new taxation policy
  - (i) reduced income in place of increasing to regular more taxation on those objects which have elasticity of demand. That is why on regulation of more tax on that object, price will be increased. Due to increase in price, demand would be reduced.
  - (ii) The goods which are non-elastic, finance minister can increase price more but there is no more affect on demand so, income tax will get more.
5. **Distribution of Burden of Taxation:** By price elasticity of demand, it can be fixed like sales tax, production tax etc. whole how much affect a consumer and procedure of non-elasticity Demand of a object than indirect tax would affect more on consumer. Due to these tax prices object will be in demand but there will very less reduction in demand but there will very less reduction in demand. Opposite to it, if elasticity on indirect tax is relatively less consumers will bear the burden of indirect taxes.
6. **International Trade:** There is great importance of conception of elasticity demand in international trade. One country will get income after these important objects has non-elastic demand. If importing country has elastic demand of these objects then exporting country will reduce price of their exported object and will increase total export and will take advantage by this process. Like this a country will import on less process of those objects whose demand has elasticity.
7. **Paradox of Poverty:** People, who are related to agriculture are well familiar that even after good product of many agricultural products, income in money is less. It means that there is less income after more production. This unnatural condition is called paradox of poverty. It is because that maximum agriculture product has elastic demand. When these goods get low price after increasing product then demand of them has not increased. That is why income by selling these saved is low.

## 6.23 Summary

- These days the concept of Elasticity of Demand is very much important for producers. To increase their income, they should reduce the price of their product on that time when the elasticity of demand is

**Notes**

more than per unit of demand. The reason behind this, the cost of a product increases when elasticity of demand is high and the price of that product is low. The producers should increase the price of their product when the elasticity of demand decreases than unity.

### **6.24 Keywords**

- **Market Demand:** Total demand from buyers
- **Inferior Goods:** Poor Goods
- **Extension of Demand:** Rise in demand
- **Contraction of Demand:** Low in demand

### **6.25 Review Questions**

1. What is the meaning of conception of demand? Explain it.
2. What do you mean by Price Elasticity of Demand?
3. What is Point Elasticity Procedure? Explain with example.
4. What is Cross Elasticity of Demand and its types?

### **Answers: Self Assessment**

- |           |           |           |          |
|-----------|-----------|-----------|----------|
| 1. Prices | 2. Price  | 3. Direct | 4. (a)   |
| 5. (b)    | 6. (a)    | 7. (a)    | 8. True  |
| 9. True   | 10. False | 11. False | 12. True |

### **6.26 Further Readings**



*Books*

1. **Microeconomics**—*Frank Cowbell, Oxford University Press, 2007.*
2. **Microeconomics**—*Shipra Mukhopadhyay, Annie Books, 2011.*
3. **Microeconomics: An Advanced Treatise** – *S.P.S. Chauhan, PHI Learning.*

## Unit-7: Recent Developments in Demand Theory

### CONTENTS

Objectives

Introduction

- 7.1 The Pragmatic Approach to Demand Theory
- 7.2 The Linear Expenditure System
- 7.3 The Indirect Utility Function
- 7.4 The Expenditure Function
- 7.5 Lancaster's Attributes or Characteristics Demand Theory
- 7.6 Summary
- 7.7 Keywords
- 7.8 Review Questions
- 7.9 Further Readings

### Objectives

After studying this unit, students will be able to:

- Know The Pragmatic Approach to Demand Theory.
- Understand The Linear Expenditure System.
- Study The Expenditure Function.
- Know The Lancaster's Attributes or Characteristics Demand Theory.

### Introduction

Recently, the economists have raised a question over the profitability behavioural economics and accordingly to make the demand theory more realistic they have created some models and rendered some theories. In this chapter, The Pragmatic Approach to Demand Theory, in which functions of stable elasticity demand, dynamic demand functions and empirical demand functions are included, and the Linear Expenditure System, The Indirect Utility Function, The Expenditure Function and Lancaster's Attributes or Characteristics Demand Theory have been deliberated.

### 7.1 The Pragmatic Approach to Demand Theory

The conventional consumer behaviour and the advanced theories provide the economists a theoretical basis for their models, but they cannot be used direct for the complex problems of the real world. But

**Notes**

still, they provide the starting point of the function of market figures. That is why the economists have studied functions of demand through both the views, static as well as dynamic. Accepting the basic rules of demand, they have predicated the multivariate demand functions, in which the demand of a product is not only the function of its price but also the function of various other variables. These variables include prices of other products, income of the consumer, consumer interests etc. These functions have concentrated the supremacy on consumer market demand and not on personal consumer demands. Then some demand functions study the different groups of products like eatable products, demand for services etc. This is called **The Pragmatic Approach to Demand Theory**. We shall analyze certain some demand functions below.

**1. The Constant Elasticity of Demand Function**

In many statistical studies, Constant Elasticity of Demand Function is used. It is based on general believes of the relation between demand and its determinants like price of the product, price of related goods, income of the consumer etc. It is assumed that income of the consumer and price of related goods are constant. Based on this, in demand function, the relation between price-quantity can be differentiated. As far as the shape of demand function (curve) is concerned, the curve is fitted based upon statistical figures. But this curve is deceptive as it never shows accurate results and rather is based on approximations.

The general form of Demand Function is,

$$Q_x = a \cdot P_x^b P_0^c Y^d e^{f_t} \dots(1)$$

where,  $Q_x$  = Quantity of demanded product x

$a$  = constant

$p_x$  = price of x

$b$  = price function of demand

$p_0$  = price of other unrelated goods

$c$  = cross elasticity

$y$  = income of the consumer

$d$  = income function of demand

$e$  = basis of natural logarithms

$f_t$  = trend factor for interest

The equation (1) is known as Constant Elasticity of Demand Function because the variables of demand  $b$ ,  $c$  and  $d$  are assumed to be constant.

**Its Proof**

To prove this we take the short multiple of price and product  $x$ , assuming other determinants of demand as constant.

For constant price demand of demand function,

$$b = \frac{\Delta Q_x / Q_x}{\Delta P_x / P_x}$$

is a constant.

Using this feature mathematically, changing variables show the proportional change, we can write it as,  $\Delta \log Q_x = b \log P_x$

where  $\Delta \log Q_x = \Delta Q_x / Q_x$ ,  $\Delta \log P_x = \Delta P_x / P_x$  and  $b$  is price function of demand.

because of which,

$$b = \frac{\Delta Q_x / Q_x}{\Delta P_x / P_x}$$

where  $b$  is assumed to be constant.

By analysing Constant Elasticity of Demand Function of  $P_x, P_o$  and  $Y$  in form of multiple is presented as,

$$\log Q_x = \log a + b \log P_x + c \log P_o + d \log Y \quad \dots(2)$$

To simplify  $e^b$  has not been taken from Equation (1),

Converting Equation (2) into units, it becomes,

$$Q_x = a P_x^b P_o^c Y^d \quad \dots(3)$$

### Graphic Presentation

Constant Elasticity of Demand Function is presented graphically in Fig. 7.1 which has been created by fixing a fictional set with data. In this way D curve represents the Constant Elasticity of Demand Function.

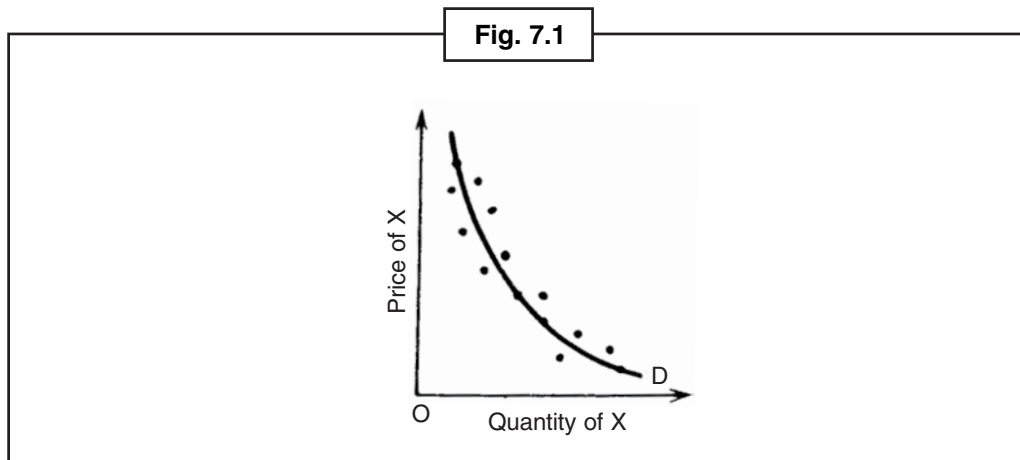

In general, the zero category of demand function, in Equation (3), is described in a homogeneous form by the economists. This is done with actual income and relative prices in demand function.

$$Q_x = \left(\frac{P_x}{P}\right)^b \cdot \left(\frac{P_o}{P}\right)^c \cdot \left(\frac{Y}{P}\right)^d \quad \dots(4)$$

where  $P$  is the general price indicator.



*Notes* Recently, the economists have raised a question over the profitability of these in behavioural economics and accordingly to make the demand theory more realistic.

## 2. The Dynamic Demand Functions

In demand theory, another development is the dynamic demand functions which are known as Distributed lag models of demand.



**Notes**

In dynamic demand function, after income and demanded quantity the value is included in different forms of variable. It is based upon stock adjustment principle which says that the present demand decisions are influenced by past behaviour. It is believed that the present demand depends upon past income and levels of demand. For a permanent consumer the past purchase is the stock of the product, which clearly influences its present and future purchases (like fans, sewing machines, etc.). But for non-permanent consumer, the products like, eatables, beverages, cigarette, etc. depicts a 'habit' which in present is accepted by purchasing and consuming and because of which the levels of the purchase in present and in future affects the demand structure. Then, the levels of demand or income of very near present have a greater influence on present consumption structure as compared to far off levels. For example, compared to the income earned before 5-10 years has less effect on us as compared to the influence of last year's income.

Distribution and urinary distribution of income model can be presented as follows:

$$Q_t = f(P_t, P_{t-1}, \dots, Q_{t-1}, Q_{t-2}, \dots, Y_t, Y_{t-1}, \dots)$$

where,

$Q_t$  = quantity of the purchased product

$P_t$  = present price of the product

$P_{t-1}$  = price in period 1

$Q_{t-1}$  and  $Q_{t-2}$  = quantity purchased in period 1 and 2

$Y_t$  = present income of the consumer

$Y_{t-1}$  = income of the consumer in period 1

This function shows that price determining present demand, is influenced by demand and income of past levels.

(1) **Demand Function for Consumer Durables:** The above demand function is based upon the Stock Adjustment Rule of Nerlove and when it is applied to the consumer durables the following forms come into being,

$$Q_t = aY_t + bQ_{t-1} \quad \dots(1)$$

Where,  $Q_t$  = present purchase  $Y_t$  = present income  $Q_{t-1}$  = quantity purchased in the last period and  $a$  and  $b$  are the parameters.

This function can be derived by the following way.

The level of desired product is  $Q_t$  which is determined by present income  $Y_t$ .

$$Q_t = cY_t \quad \dots(2)$$

Where  $c$  is the parameter.

But due to their limited income, inadequate savings, credit limitations, etc. the consumers cannot purchase the desired levels of durable foods too soon. That is why the consumers purchase a part of their desired levels in one period. If the purchased quantity in the last period has **Realistic Change**  $Q_t - Q_{t-1}$ , then this only a part  $k$  of the desired change,  $Q_t - Q_{t-1}$  therefore,

$$Q_t - Q_{t-1} = k(Q_t - Q_{t-1}) \quad \dots(3)$$

Where  $Q_t - Q_{t-1}$  is the realistic change,  $Q_t - Q_{t-1}$  is the desired change, and  $k$  is the multiple of Stock Adjustments; and  $0 < k < 1$ .

By substituting Equations (2) and (3), we get

$$Q_t - Q_{t-1} = k(cY_t - Q_{t-1})$$

Again re-arranging,

$$Q_t = (kc) Y_t + (1-k) Q_{t-1}$$

$kc = a$  and  $(1 - k) = b$  by setting  $b$ , we reach to Equation (1)

$$Q_t = aY_t + bQ_{t-1}$$

(2) **Demand function for Consumer Non-durables:** **Hauthekar** and **Taylor** formulated habit formation principle in place of Nerlove's stock adjustment rule and spread it to non-durables. In this demand function, present demand of non-durables, in addition to other things, depends upon last purchase of goods ( $Q_{t-1}$ ) which are based on habits.

$$Q_t = a + b_1 P_t + b_2 \Delta P_t + b_3 Y_t + b_4 \Delta Y_t + b_5 Q_{t-1}$$

Where,  $a$  = constant,  $P_t$  = present price,  $\Delta P_t$  = change in price,  $Y_t$  = present income,  $\Delta Y_t$  = change in income and  $b_1$  to  $b_5$  are the parametric coefficients.

In reality, the demand function for non-durables is derived from durable goods, which depends upon present price in a period, stock of durable goods, and habit of non-durable goods and level of present income.

(3) **Empirical Demand Function:** Generally, demand function of a product is written in this way

$$Q = F(P, P_c, P_s, Y, T)$$

Where,  $Q$  = quantity of the demanded product,  $P$  = price of the product, price of complimentary goods,  $P_s$  = price of established goods,  $Y$  = income of the consumer and  $T$  = interests of the consumer.

This function shows that demand of a product depends on its price, price of its complimentary and established products and income of the consumer.

But this function is so ordinary that it does not have an empirical suitability. It only tells a form without any result of the relation between the demanded quantity of the product, dependent variable  $Q$  independent variables  $P, P_c, P_s, Y$  and  $T$ , every determinant has a function. It is important to express that how much measurable effect does the price of one product has over the price of other products in order to estimate an empirical demand function. If interests remain constant over time no problem arises and  $T$  can be evaluated by estimated equation. If interests keep changing, then time is taken as a variable in the form of a change. Secondly, for some time, interests might change due to financial and political components. That is why a dummy variable  $D$  is used for that period. Then, at one error  $u$  is also used in the function.

To analyse statistical figures techniques like multiple regression are used which allow to use the estimated data of demand function and its determinants.

To estimate the shape of multiple is added while joining the various independent variables with the demanded quantity a special form of function is needed. There are two forms in general; linear demand function and exponential demand function.

**Linear demand function** can be written as

$$Q = a + b_1 P + b_2 P_c + b_3 P_s + b_4 y + b_5 T + b_6 D + u$$

It can be estimated if figures are available for every variable and if there is sufficient observation to apply the technique of multiple regression and then for Intercept a multiple of  $a$  and demanded quantity over every determinant ( $b_1$  to  $b_6$ ) can show its effects. Once they are estimated, it is possible to solve the demanded quantity for every determinant. This is done by including these values into equations.

For **exponential demand function**, the estimated elasticity, i.e., own price, cross-price elasticity and elasticity are considered to be constant at the entire range of figures. It is also assumed that the interests in function are

Notes

**Notes**

constant and errors are eliminated so that for simplification  $T, D$  and  $u$  are not taken into the equation. Like this exponential demand function is an option for linear demand function which can be written as:

$$Q = P^a P_c^b P_s^c Y^d$$

In this form,  $a, b, c$  and  $d$  variables are exponentials and are the logarithms for the above demand function.

It can be written in a linear form as:

$$\log Q = a \cdot \log P + b \cdot \log P_c + c \cdot \log P_s + d \cdot \log Y$$

The various elasticity of demand, of this equation, can be estimated and the techniques of multiple regressions can be used to estimate this.

**Self Assessment**

**Fill in the blanks:**

1. Constant regression ..... is used to study statistical studies.
2. The formation of indexes is related to various .....
3. While estimating demand curve ..... problem arises.

**Empirical Demand Curve:** An empirical demand curve is fitted or derived by various prices over demanded quantity of the product observed market figures, assuming this that price of related and substitute goods and income of the consumer and interests are constant.

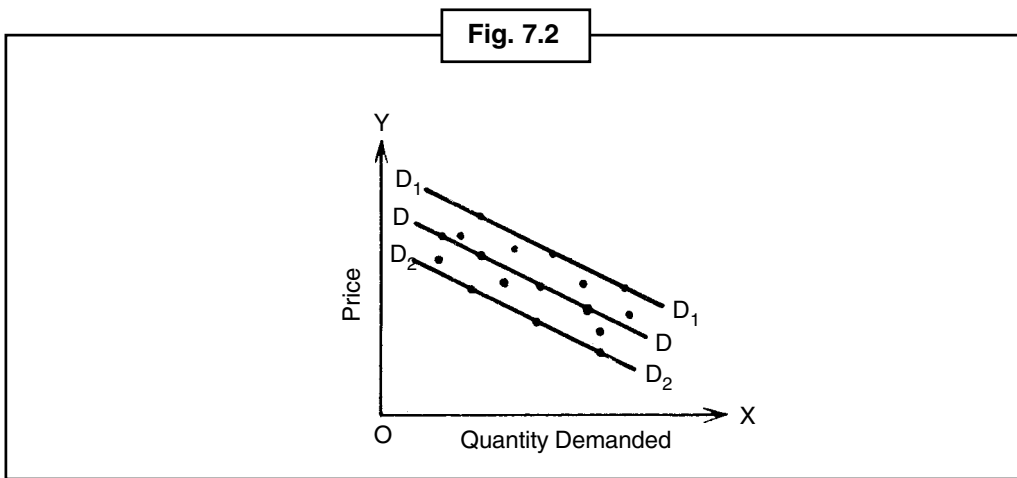

This is shown in Fig. 7.2 with DD demand curve. The demand curve can go downwards on  $D, D_1$  or  $D_2$ , if the price of substitution product and the income of consumer are changed.

**Limitations of Demand Functions**

In the behavioural notion of demand theory, the above mentioned demand functions estimation has many limitations:

- (1) The problem of agglutination between products and people arises because of which use of indexes is required. But the creation of index creates a lot of trouble.
- (2) Estimation of the demand curve is also difficult, when the change occurs in the determinants of demand at the same time. Because of this it becomes very difficult to evaluate the effect of every determinant individually.

- (3) To estimate the demand curve, multiple regression concept is 'Best Fit' for the numerical numbers. But 'Best Fit' can be poor and can describe a very small ratio of change in demand curve.
- (4) The personal calculation in demand curve is just a good assumption, if the restricted assumptions of errors are valid. If it is not then this might do correction which is not necessarily good.
- (5) The integration is a big score while assuming the demands curve. The demand curve is best fit if it is drawn by the price of a product and a set of its demand. But if the supply curve shifts, then the traced points of supply curve can integrate the demand curve too. To solve the integrated portion of demand curve, there are so many equations needed which is a big and complex process.



*Did u know?* To estimate the demand curve, multiple regression concept is 'Best Fit' for the numerical numbers.

## 7.2 The Linear Expenditure System

**Prof. R. Stone** has proposed the model of linear expenditure system based on the utility function in which by maximizing utility function subject to a budget restriction demand function can be derived in a general way. In this aspect, the concept of LES is similar to the concept of an indifference curve. But there are two differences between them - (1) Indifference curve is related to individual commodity whereas LES is related to group of commodities (2) In the indifference curve system, substitution in a single of goods can be done whereas LES substitution between the groups cannot be done.

### Its Assumptions

A model of Linear Expenditure System is based on following assumptions:

1. Consumer goods have five groups A, B, C, D and E.
2. Each group of goods includes all substitutes and complements.
3. There is no substitution of goods between groups but there can be substitution in a single group.
4. Income of the consumer is given and fixed.
5. The consumer without considering the price of the commodities, purchases minimum quantity of goods from each group. These are called subsistence quantities which the consumer spends on maintaining his life and the money spent on these are known as subsistence income. The remaining income which is called additional income is allocated among the various groups of commodities on the basis of its price.
6. The consumer works rationally.
7. Utilities are additional.

### Model of LES

On these given assumptions, **Prof. Stone** has proposed a useful utility solution of groups of products in logarithms.

$$U = \sum_{i=1}^n a_i \log(Q_i - C_i)$$

That is  $U = U_A + U_B + U_C + U_D + U_E$

or  $U = (Q_1 - C_1)^{a_1} \cdot (Q_2 - C_2)^{a_2} \dots (Q_n - C_n)^{a_n}$

or  $U = a_1 \log(Q_1 - C_1) + a_2 \log(Q_2 - C_2) + a_n \dots \log(Q_n - C_n)$   
 [  $0 < a_i < 1$ ;  $> C_i > 0$ ;  $(Q_1 - C_1) > 0$  ]

**Notes** The consumer maximizes his total utility under his restricted income and his utility calculation is –

Maximize 
$$U = a_1 \log (Q_1 - C_1) + \dots + a_n \log (Q_n - C_n)$$

Subject to 
$$Y = \sum P_i Q_i$$

The restricted utility function gives following demand function –

$$Q_i = C_i + \frac{a_i}{P_i} (Y - \sum P_i C_i) \quad \dots (1)$$

Where

$Q_i$  = The demanded quantity of group  $i$

$C_i$  = Minimum quantity of group  $i$  product

$a_i$  = Portion of marginal budget means if total income changes by an unit then how much group  $i$  increased his expenditure

$p_i$  = Price sign of group

$Y$  = Total income of consumer

$(\sum P_i C_i)$  = Life dependent income of consumer

$(Y - \sum P_i C_i)$  = Extra income of consumer

The demand function (1) can also written as follows –

$$P_i Q_i = P_i C_i + a_i (Y - \sum P_i C_i)$$

This should read the expenditure of consumer in group  $i$  products  $P_i Q_i = P_i C_i$  (his life dependent expenditure) +  $[a_i (Y - \sum P_i C_i)]$  his additional expenditure.

### Self Assessment

#### Multiple choice questions:

4. Consumer goods have five groups –
 

(a) K, Kh, G, Gh, Ng	(b) A, B, C, D and E
(c) A, B, C, D	(d) Y, R, L, V
5. The demand curve is ..... if it is drawn by the price of a product and a set of its demand.
 

(a) fixed	(b) variable
(c) best Fit	(d) valuable
6. Rest of income is called .....
 

(a) curved Income	(b) positive Income
(c) negative Income	(d) additional Income
7. The quantity which consumer buys for his life is called .....
 

(a) life units	(b) multiple units
(c) dismultiple units	(d) curve units

### 7.3 The Indirect Utility Function

In the words of linear programming techniques, the indirect or direct utility function describes the problem of utility maximization.

To solve the problem of utility maximization, we write as—

Notes

$$\begin{array}{ll} \text{Max} & U(X) \\ \text{Subject to} & \sum_i p_i X_i \leq Y \end{array} \quad \dots(1)$$

Where  $X_i$  = Utility bundle of  $i$  products  
 $U$  = The utility from utility bundle  
 $P_i$  = Price of  $i$  products  
 $Y$  = Total income of consumer

Suppose that  $\lambda_i = P_i/Y$  and now the problem of utility maximization can be written as follows—

$$\begin{array}{ll} \text{Max} & U(X) \\ \text{Subject to} & \sum_i \lambda_i X_i \leq 1 \end{array} \quad \dots(2)$$

Where  $\lambda_i$  is normalized price.

In this form, there are two sets of problem of utility maximization— (i) Consumption units with price and (ii) Normalized price with  $\lambda = \lambda_1, \dots, \lambda_n$  price.

The optimum demand function can be given as follows—

$$X_i = D_i(\lambda) \quad i = 1, \dots, n \quad \dots(3)$$

The maximum utility level can be obtained by substitution of equation (3) into equation (1). Further, this optimum utility bundle depends on vector of prices which shows in equation (3). The indirect utility function is derived from it.

$$V(\lambda) = U(d, (\lambda) \dots d_n(\lambda) \quad \dots(4)$$

$V$  is called indirect utility function because it depends upon income level and a set of normalized prices  $\lambda$ .

### Properties of Indirect Utility Function

Following are the characteristics of Indirect Utility Function:

1. If  $U$  is continuous, then  $V$  is also continuous to all positive sets of  $\lambda$ .
2.  $U$  is not increased because if the income decreases or price increases, then it does not maximize the utility function. It is correct if  $U$  increases in utility bundle  $i$ th.
3.  $U$  does not decrease if  $i$ th is normalized price however  $U$  is increasing in  $i$ th utility bundle.
4. If there is a corner solution means  $X_i = 0$  then the utility of consumer not changes if  $P$  increases. For example, if the price of Maruti Zen is increased then it does not affect on maximum consumer's utility levels.

### Graphical Presentation

The indirect utility function is drawn by indirect indifference curves. Suppose that only two consumer goods are 1 and 2 whose normalized prices are  $\lambda_1$  and  $\lambda_2$  which are on vertical and horizontal axis as shown on Fig. 7.3. An indirect indifference curve  $IIC_2$  shows the combinations of normalized prices on  $\lambda_2$  which is untouched to maximum utility level. If the consumer is not satisfied from any of the product

**Notes**

on IIC<sub>2</sub> and goes to high curve IIC<sub>3</sub> then the normalized price of both the products increases and utility decreases. In contrast if consumer goes to downward curve IIC<sub>1</sub> then the normalized price of both the products will fall and utility will rise. Thus, in an indirect utility function the high indirect indifference curve has low utility level and vice versa.

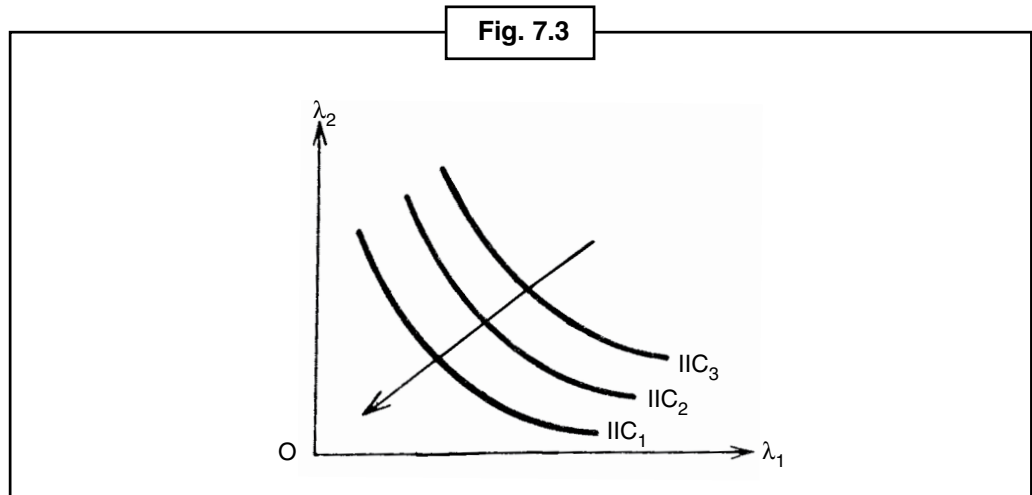

**Its Dual**

The dual of the problem of utility maximization is utility minimization and which can be written as follows –

$$\begin{aligned} \text{Min} & \quad V(\lambda) \\ \text{Subject to} & \quad \sum_i \lambda_i X_i \leq 1 \end{aligned} \quad \dots(5)$$

To minimize the utility level, we assume the utility bundle as fixed and take a normalized price  $\lambda$ . The solution of this minimization represents by  $n$  following set of equations –

$$\lambda_i = a_i(X) \quad i = 1, \dots, n, \quad \dots(6)$$

by taking only two products 1 and 2,

$$\lambda_1 X_1 + \lambda_2 X_2 = 1$$

to solve this for  $\lambda_2$

$$\lambda_2 = (1/X_2) - (X_1/X_2) \lambda_1$$

$1/X_2$  is budget restriction for product 2.

Thus, for  $\lambda_1$ ,  $1/X_1$  is budget restriction for product 1.

The solution of minimum utility function is shown as per above equations in Fig. 7.4 where vertical restriction is  $1/X_2$  and horizontal restriction is  $1/X_1$ . We trace the budget line by mixing it.

The optimum solution point for minimum utilization is M where the budget line touches the indirect indifference curve IIC<sub>2</sub> because it is higher possible indirect indifference curve with minimum utility level. The curve IIC<sub>1</sub> cannot give the solution of minimum utility because the utilization is higher from

IIC<sub>2</sub> curve than IIC<sub>1</sub> curve. Thus, the curve IIC<sub>3</sub> does not give optimum solutions, however, the utility level is lower than IIC<sub>2</sub> because it is above to consumer budget line  $1/X_2 - 1/X_1$ . So only point M is optimum normalized point.

Notes

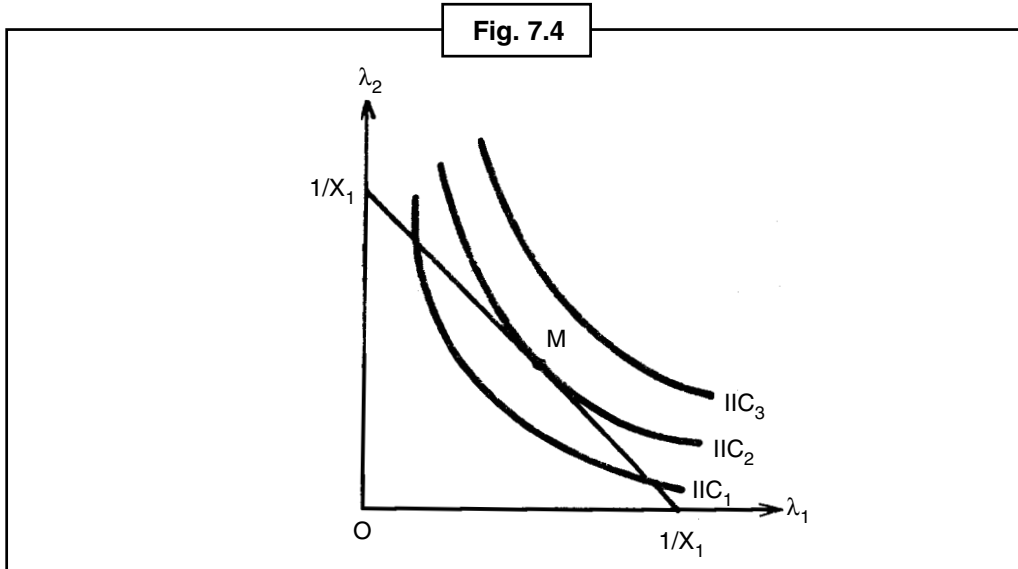

### Difference between Direct and Indirect Utility Functions

Direct utility function is related to neutral curve system and also the indirect utility function is related to indifferent curve which are known as indirect neutral curve. They are similar in following ways -

1. Both the curves look same.
2. Both are convex on the base.
3. Customer is neutral on any point of these curves because it obtains same functions on each.

But there is a main difference in these two types of curves. High direct neutral curves are related to high function levels. Opposite to it, high indirect neutral curves are related to lower function levels.

### 7.4 The Expenditure Function

The expenditure function states that how the customer decreases its expenditure, derivation of customer's expenditure function depend on programming technique on given costs of products and utility level.

$$\begin{aligned} &\text{Min} && \sum_i P_i X_i \\ &\text{Subject to} && U(X) \geq U \end{aligned} \quad \dots(1)$$

Where  $P_i X_i$  is total expenditure which is to be done minimum but with the condition that utility of this restriction would not less than level  $U$ . Solution of equation (1) depends on the values of costs and utility level which is written as:

$$X_i = f_i(P, U) \quad i = 1, \dots, n \quad \dots(2)$$



**Notes**

By substituting this function into observed function a function is obtained which expresses the minimum level of expenditure which can earn utility level U, on given costs P,

$$\sum_i P_i f_i(P, U) \quad \dots(3)$$

This is customer's expenditure function.

Figure 7.5 shows, two products  $X_1$  and  $X_2$ , their prices  $P_1$  and  $P_2$  and customer's revenue level  $Y_1$ . Product  $X_1$  is taken on horizontal axis and product  $X_2$  is taken on vertical axis. By joining confinements  $Y_1/P_2$  and  $Y_2/P_2$  budget line is made which represents the customer's expenditure level. Budget line  $Y_0/P_2 - Y_0/P_1$  images the lower revenue level.

To solve the expenditure minimization problem (1) is to obtain utility level U which is represented by neutral curve which touches the lowest budget line among all the budget lines. The point where budget line  $Y_1/P_2 - Y_1/P_1$  touches the neutral curve U is E. It is the point where customer minimizes his expenditure on two products  $X_1$  and  $X_2$  on given its income  $Y_1$ .

To prove it, take budget line  $Y_2/P_2 - Y_1/P_1$  which is favourable to  $Y_2$  revenue level where neutral curve U cuts it on  $E_1$  and  $E_2$ . Customer obtains utility level U on  $E_1$  and  $E_2$  but does not fulfil the costumer's condition of equilibrium on any point among these. These are (i) slope of budget line at equilibrium point and slope of neutral curve would be same and (ii) neutral curve would be at tangent point. These conditions are not fulfilling on points  $E_1$  or  $E_2$ . Now take budget line  $Y_0/P_2 - Y_0/P_1$  which is favourable to revenue level  $Y_0$  which is under the neutral curve. Here, customer cannot obtain neutral curve U which represents utility level with its revenue level  $Y_0$ . Therefore, it is the only point at which customer minimizes its expenditure by earning utility level U.

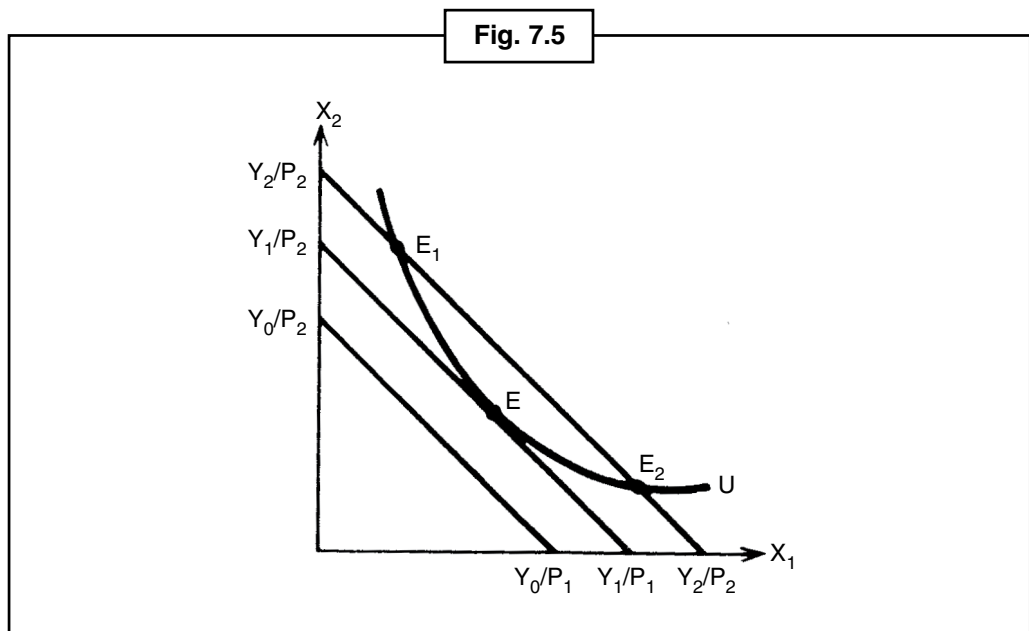

**Fig. 7.5**



Task

Give your views on customer expenditure function.

## 7.5 Lancaster's Attributes or Characteristics Demand Theory

**Prof. Lancaster** proposed a new customer's theory based on characteristics of products in 1966. According to this theory, characteristics of products not only give product utility and describe products as bundle of characteristics. Let's take the example of bread, whose characteristics include taste, calorie, protein etc. Even then, there can be same characteristics in different products with other characteristics in different mixtures. There are different bundles of varieties of sweetness, good smell, juiciness, vitamins, many varieties of apple, mango, orange etc. There is different bundle of characteristics in a 'golden' apple in comparison to 'sweet red' apple. According to **Lancaster**, every product presents consumption technology to produce characteristics.

### Its Assumptions

To describe Lancaster's Demand Theory, we take the assumptions described below.

1. Three varieties or brands of apples.
2. They have only two qualities – sweetness and juiciness.
3. There are only these three brands of apples to produce sweetness and juiciness.
4. Can be measured in sweetness and juiciness.
5. Cost of one brand is different from others.
6. Income of customer is given.
7. Intension of customer is to maximize its utility with a mixed bundle of characteristics.

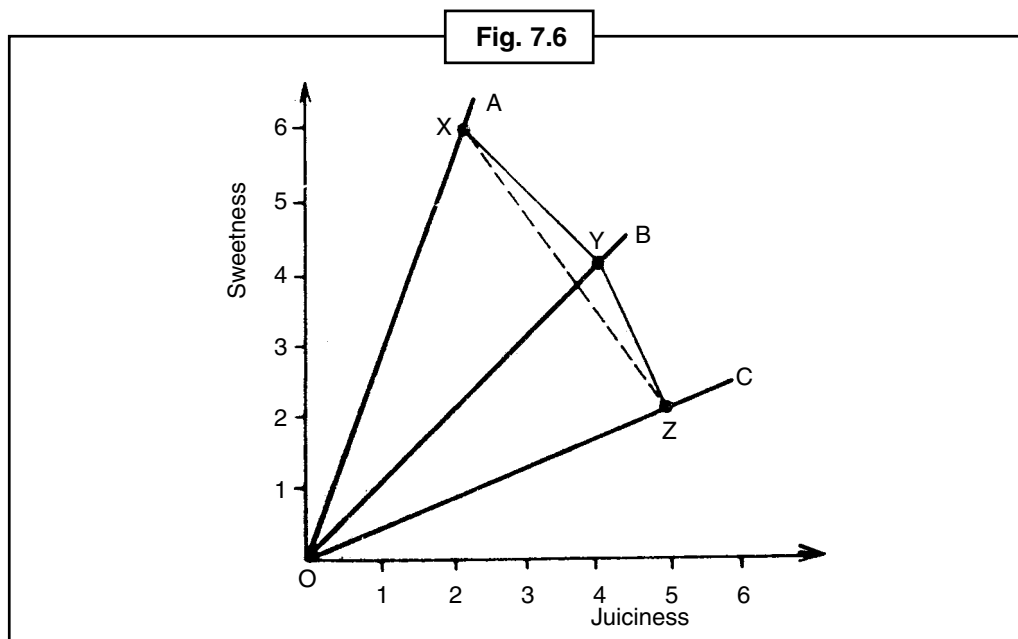

### The Theory

On given these assumptions, a customer who consume only one variety of apple which described the characteristics of sweetness and juiciness of that variety in table 1 can be consumed only in that ratio.

Notes

Variety	Sweetness	Juiciness
A	6	2
B	4	4
C	2	5

In Fig. 7.6, sweetness and juiciness are measured on vertical axis and horizontal axis respectively. If every variety of apple's characteristics is shown in table, then a variety of more quantities will provide combination of represented characteristics by the rays of OA, OB and OC to the customer in figure.

On given customer's income and price of every variety of apple, let customer buy OX quantity of A or OY quantity of B or OZ quantity of C. By joining X and Y and Y and Z points customer can do different mixture consumption of combination of both the qualities of different quantities of three varieties of apple. XY line is customer's budget line or attributes possibility frontier or efficiency frontier which represents those combinations which the customer can obtain by spending his income on different mixtures of A and B varieties of apple. It is similar for YZ budget line, which is related to B and C varieties. This way, budget line XYZ represents the different combinations of both the characteristics, which the customer can obtain on given prices of all the three varieties of apple and his income.

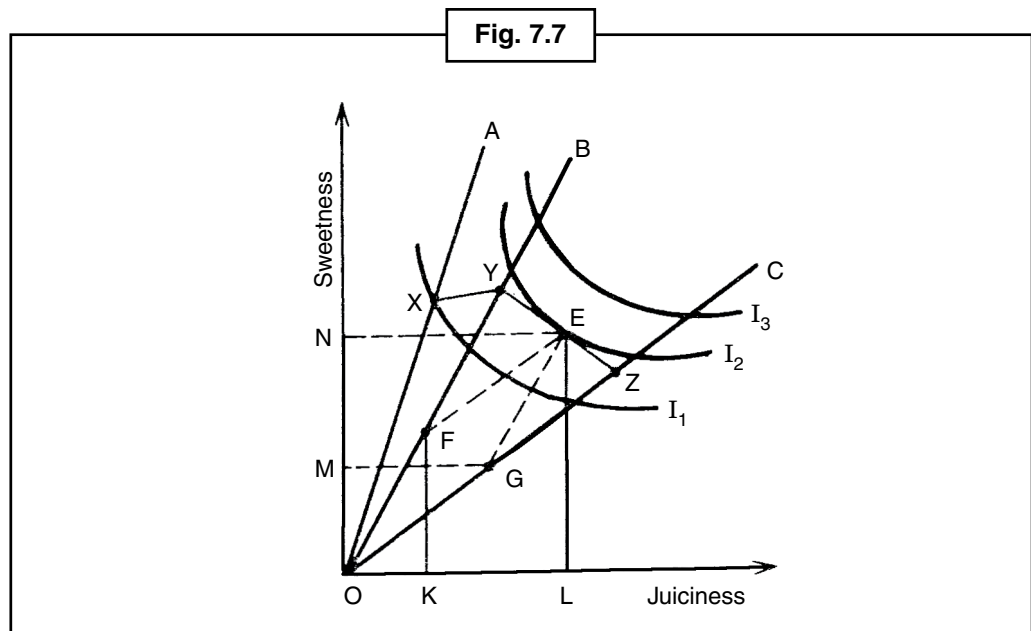

Pointed line between X and Z shows two combinations between two specialities when consumer can obtain by expenditure of combination of A and C brands because this line XZ situated is below line XYZ. So consumer receives less quantities even after expenditure of same income in comparison of others coincidence on both specialities. So a clever consumer will avoid this situation.

Consumer chooses combination of both specialities by evaluation of under change of uses within budget in respect of value and their interest. Value of consumer is shown neutral curve on specialities. Neutral curve on special place of consumer and type of touch object within budget line. He will choose coincidences of speciality where budget line or highest line touches neutral line. It is shown in Fig. 7.7 which touches XYZ budget line on point E units, neutral curve  $I_2$  between OB and OC object ray.

For knowing solid count of both specialities from point E to parallel to ray OC point F on ray OB a line has drawn like this from line E parallel to ray OC on point G on OB has drawn a line consumer buys micro combination of both speciality of both types of apple or brand B units points E forward from O to F on ray OB and then buy units of brand C of F to E.

Like this, on other side, the macro combination of speciality of both brands for brand C point O to G and for brand B, G to e can be obtained.

Same calculation comes out from both types by which consumer OF (= GE) brand B units and units of brand C, OG (= FE). Similarly, consumer gets OK units of juiciness for brand B and KL juiciness for brand C and OM units of sweetness from C and MN units for brand B.

It is important to note, that  $I_1$  cannot be on the neutral curve because this is below its budget boundary xyz and he can buy only brand A in point x which according to assumption he has to buy combination of two brands. Again, it cannot be on  $I_3$  curve because it is situated above its budget line XYZ, so it maximizes its utility only on point E of  $I_2$  curve where this curve touches its budget line XYZ.

This speciality they describe like analysis of neutral curve for affecting of selection of brand of commodity, changes in price, income and quality by consumer.

### The price effect of law of demand

In **Lancaster theory**, change in price of brand of a commodity on demand to consumer and selection of commodity on demand of consumer and selection of speciality can be explained.

**Fall in Price:** On given price of a brand or a commodity and income of consumer, suppose that consumer is in equilibrium on point E in Fig. 7.8 where YZ part of budget line XYZ touches neutral curve  $I_1$ . It is getting speciality OG (=FE) from brand C and OF (=GE) from brand B. Now price of brand B reduces, on given income of consumer point Y of line OB shifts to  $Y_1$  in above by which a new budget line XYZ becomes  $OXY_1Z$  is called probability area. New equilibrium is on point  $E_1$  where neutral curve  $I_2$  touches  $Y_1Z$  part of this area. In result, consumer buy more  $OF_1$  quantity of brand B before it and brand C, less quantity  $OG_1$  buy less as before. **Lancaster** says it efficiency effect which on reducing price of B, change in combination of brand B and C. It is equal to substitution effect of neutral curve analysis except it is for him is substitutions of speciality.

Notes

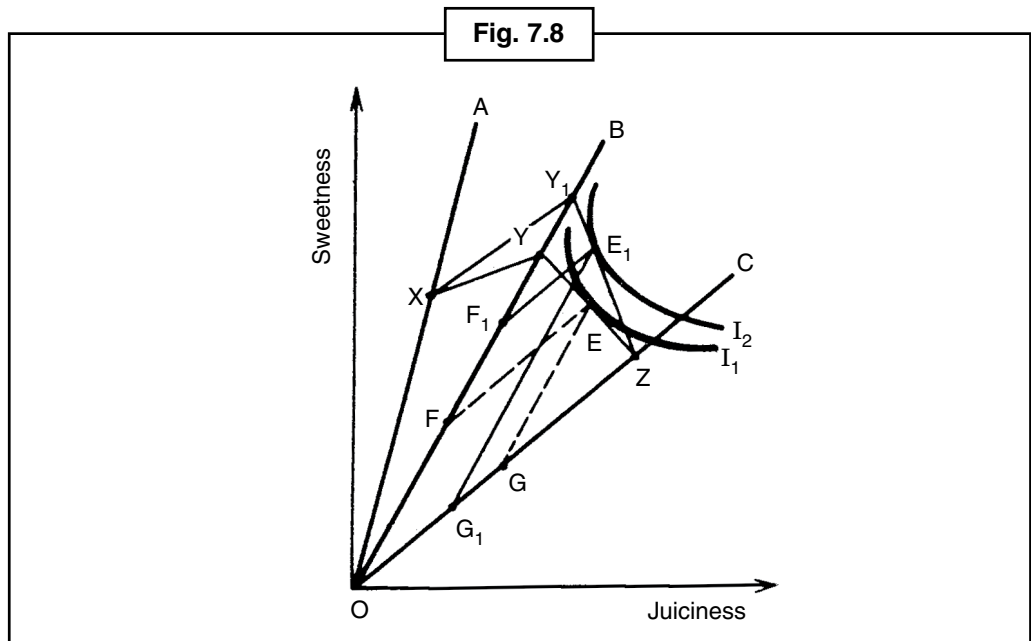

New brand combination of B and C -  $OF_1 (=G_1E_1)$  speciality from brand B and  $OG_1 (=F_1E_1)$  speciality for brand C. So effect of reduced price of brand B, is that its demand has increased and decrease in demand of brand C. This is the explanation of demand law where the price of a brand or commodity is less. Adversely, it increases due to increase in price.

**Rise in Price:** Increase in price of brand B is shown in Fig. 7.9 where consumer initially budget line XYZ and  $I_2$  curve of touch point E are in equilibrium. Suppose that price of brand B increases in price whose result is point Y on ray OB reaches on point  $Y_0$  below by moving. Now  $XY_0Z$  budget line in low touches  $I_1$  curve on point  $E_0$  where consumer is in equilibrium. Now it substitutes brand C in place of brand B and  $GG_1$  ( $OG_1 > OG$ ) of brand buys more quantity and  $FF_1$  ( $OF_1 < OF$ ) of brand B buys less quantity as before. Here increase in price of brand B affected by **Lancaster's** ability. Increase in

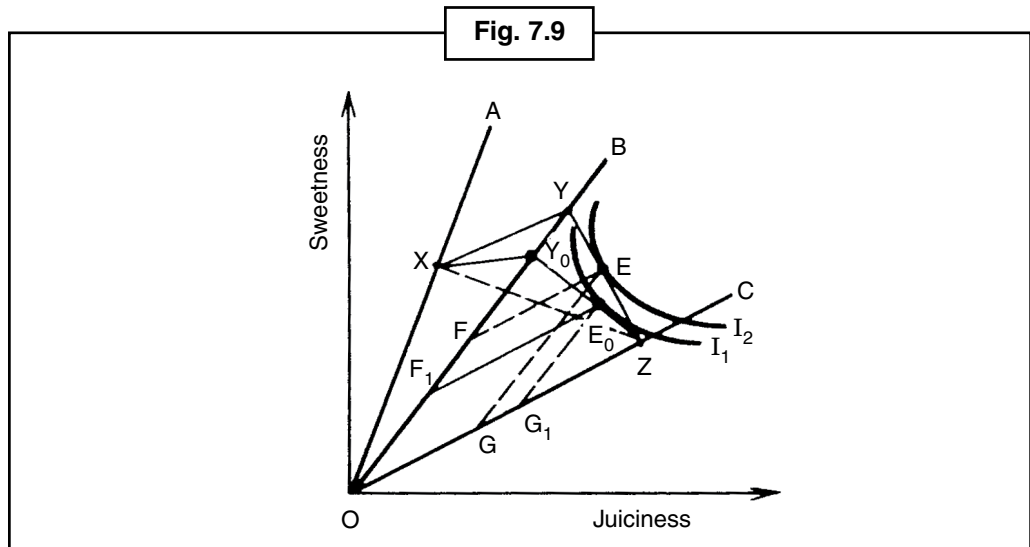

price B, affect of substitution related to specialities has been created because consumer substitutes juiciness in place of sweetness when it substitutes  $GG_1$  juiciness more than brand C to less sweetness  $FF_1$ . If the price of brand B increases to that stage when budget line becomes a line XZ, the consumer will buy brand A and C combination and will not buy brand B. As a result, brand B will be out of market due to excess of price producer brand B can get market again to reduce their price when it lies on ray OB at any point budget line XZ.

### Self Assessment

State whether the following statements are True/False:

8. Indirect utility function is drawn by indirect neutral curves.
9. High indirect neutral curves are related to low utility stages.
10. Consumer expenditure function explains how consumer spends.
11. The aim of consumers is to minimize his utility with a combination group of specialty.
12. In Lancaster's theory, there can be explanation about the change in price of brand of a commodity on consumer demand and selection of specialty.

### The Income Effect

Affect of demand of brand or commodity or change in income in consumer, given price of it, it can be described by specialty theory which is shown in Fig. 7.10. For simplifying the analysis only two brands B and C are taken while its price is given. At initial stage, consumer is on equilibrium on point E when budget line YZ is its touches neutral curve  $I_1$ . He buys OF of B (= GE) and OG of C (= FE) specialty brand combination. Suppose his income increases by which point Y goes to  $Y_1$  on line OB and on ray OC point Z increases to  $Z_1$ . Now its new equilibrium is on point  $F_1$  where budget line  $Y_1Z_1$  touches high neutral curve  $I_2$ . Due to increase in income he buys high specialty brand mixture of  $OF_1$  (=  $G_1E_1$ ) of B and  $OG_1$  (=  $F_1E_1$ ) of C. So, the effect of increased income of consumer is that he buys more quantity of both brands and maximizes its utility.

There will be opposite affects of decrease in consumer's income.

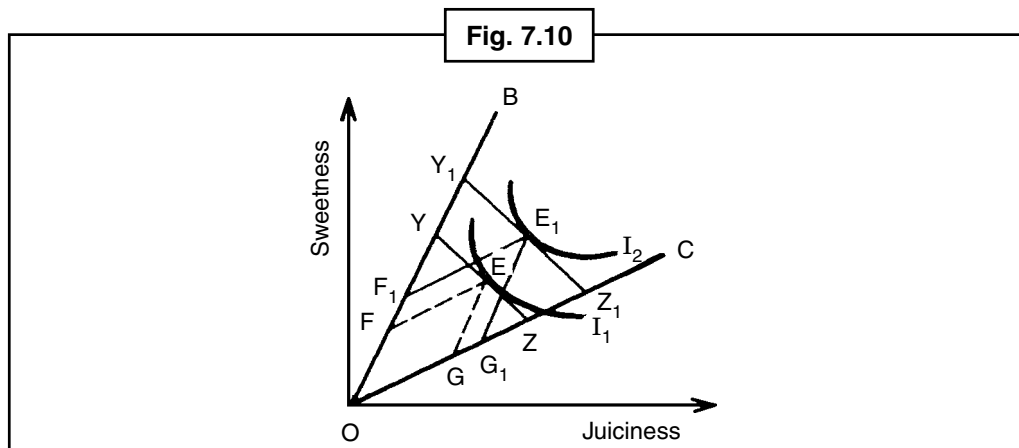

### Change in Quantity of Brand or Commodity

On behaviour of customer the demand of speciality theory describes the effect of change in quality of a brand or commodity. Suppose that there are only two brands A and B of an apple where sweetness and

**Notes**

properties of juiciness ratio are given in Table 1. Again let's suppose that customer uses only brand B, because there are equal units of sweetness and juiciness, so it maximizes its uses on point Y of ray OB. When its neutral curve  $I_1$  touches as shown in Fig. 7.11.

Now suppose a producer produces a new brand C of apples in which properties of juiciness is more than sweetness. It is shown by line OC in this figure. Price of this brand is less in comparison of other brands. Customer on this assumption changes its value from brand B to C by which the budget line XYZ of line OC goes up to XYZ. Now customer on point Z maximizes its use where higher neutral curve  $I_2$  touches.

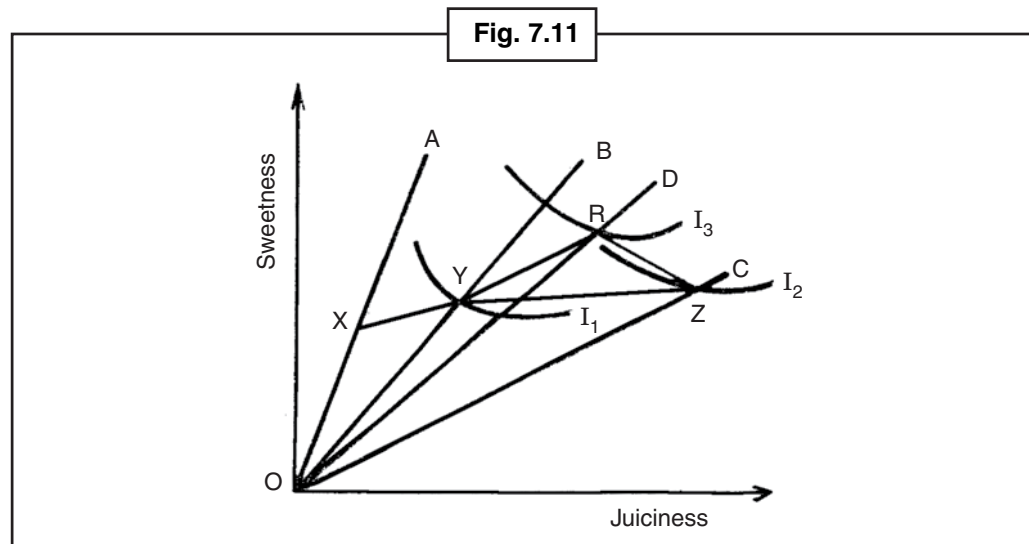

Now we take such conditions in which a producer introduces a new brand in the market in which more units of both properties are there and offers consumer a high standard. This shows object line OD in Fig. 7.11. It moves above to XYRZ and consumer goes on high consumer curve  $I_3$ , where it touches point R. Now consumer maximizes its utility by using more units of both specialities of only this brand, while it has given its income and price of the brand.

### Critical Appraisal of Lancaster's Demand Theory

In comparison of analysis of neutral curve and appeared value, theory of Marshal's demand theory, new demand theory of Lancaster's is better in following ways:

1. Earlier theory describes only demand of consumer of a simple commodity but Lancaster's demand theory is better than these theories because these commodities or its brand give more preferences to its speciality. A consumer buys a commodity not only for buying but buys so that it has some properties which give utility to him.
2. Lancaster's speciality theory is betterment of other theories of behaviour of consumer because it explains this fact content that consumer not only buys a single object but buys a bundle of mix group of objects which have different properties. It is more realistic because for e.g., consumer uses not only one vegetable but buys different vegetables which have different speciality.
3. Demand theory of classical and new classical do not give answer of this question that is why consumer gives more value to an object of a special brand in respect of others. According to Lancaster's theory, it is so that a special brand has more specialities in respect of others, which maximizes the utilities of the commodity.

4. This new theory gives a practical apparatus to researchers of a company and market by which they recognize the speciality of new brand of an object. If an object comes in market which has better and more specialities, then consumer will give more value to this brand and buys it. Theories of classical and new classical fail to describe of these sides of consumer behaviour.
5. Lancaster's Demand Theory gives a new vision of conceptions of substitutions and supplementary. According to **Lancaster**, substitutions are those objects which have some consumer properties. Those objects which have not equal properties are not related. On the other side, these objects are complementary which attend the specialities by taking two or more objects. For example, coffee, sugar and milk and candle and matchsticks are complementary.

### Its Weaknesses

Demand theory of Lancaster's has some weaknesses. For example –

- (1) Consumer has to think the specialities of an object of a brand before buying it which is subjective. Specialities of an object can be different from a consumer to another, so it could not say perfectly about specialities of units received by different brands. It is not possible to make this speciality of an object.
- (2) It has same weaknesses which remains analysis of neutral curve because it requires measurement of consumer value for mixing specialities of different types of an object which cannot be measured accurately.
- (3) One more weakness of this theory when consumers buy an object, they expend on its quantity and not for speciality found in it.

In spite of these weakness, **Lancaster's** new demand theory has an important place in economical theory for conception of substitutions and complementary, analysis of different aspects of demand theories and introducing an object and brand in market.

## 7.6 Summary

- The problem of union arose at the time of calculations of demand curve. Deriving a demand curve is better fit on the basis of a set of related observation of price and demand of an object. Other than it if supply curve shifts then point traces by supply curve can unify demand curve for the solution of problem of unification for demand curve should require pair equation in aspect of single solution which is a complex process.

## 7.7 Keywords

- **Non-durable:** Variable
- **Theory:** Assumptions
- **Subjective:** Personal
- **Weaknesses:** Feebleness

## 7.8 Review Questions

1. What is active demand function? Explain.
2. What do you mean by linear expenditure function?



**Notes**

3. Discuss the expenditure function.
4. What is Lancaster's attributes for characteristics demand theory?

**Answers: Self Assessment**

- |                    |             |                |          |
|--------------------|-------------|----------------|----------|
| 1. Demand Function | 2. Problems | 3. Unification | 4. (a)   |
| 5. (c)             | 6. (d)      | 7. (a)         | 8. True  |
| 9. True            | 10. True    | 11. False      | 12. True |

**7.9 Further Readings**



*Books*

1. **Microeconomics: An Advance Treatise**—*S.P.S. Chauhan, PHI Learning.*
2. **Microeconomics: Behaviour, Institutions and Evolutions**—*Sampool Bowels, Oxford University Press, 2004.*
3. **Microeconomics: Principles, Applications and Tools**—*Sanjay Basotiya, DND Publications, 2010.*

## Unit-8: Production Function and Law of Production

### CONTENTS

Objectives

Introduction

- 8.1 Production Function
- 8.2 Fixed and Variable Inputs or Factors of Production
- 8.3 Time Period
- 8.4 Concepts of Output or Product
- 8.5 Laws of Production
- 8.6 Returns to a Factor: Law of Variable Proportions
- 8.7 Conditions of Applicability or Causes of Application
- 8.8 Postponement of the Law
- 8.9 Returns to a Factor – A Detailed Study of Different Situations
- 8.10 Causes of Diminishing Returns to a Factor
- 8.11 Three Stages of Production
- 8.12 Significance of the Stage of Production
- 8.13 Stage of Rational Decision
- 8.14 Returns to Scale
- 8.15 Three Different Situations of Returns to Scale
- 8.16 Economies of Scale or Causes of Increasing Returns to Scale
- 8.17 Internal Economies
- 8.18 Summary
- 8.19 Keywords
- 8.20 Review Questions
- 8.21 Further Readings

Notes

**Objectives**

After studying this unit, the students will be able to:

- Know the Production Function.
- Study the theory of production.
- Know the Postponement of the Law.
- Understand the result of scale.

**Introduction**

When a factor increases in production while other factors are stable then the ratio of factors gets changed. Let's assume that there are two factors of production—Land and Labour. Land is a fixed factor. Labour is a variable factor. Suppose you have two hectares of land. You grow tomato with the help of one worker. So the ratio of labour and land would be 1:2. If you increase the worker as 2 then this ratio would be 2:2. Means initially there is two hectares land for a worker and now it is per worker one hectare. Thus if there is the change of ratio of factors, the rates of quantity of production would change.

**8.1 Production Function**

The production function states the technical or physical relation between the factors for production and quantity of products.

As per Watson, "The relation between a firm's physical production (output) and the material factors of production (input) is referred to as production function."

In the words of Ferguson, "A production function is a schedule (or table or mathematical equation) showing the maximum amount of output that can be produced from any specified set of inputs, given by the existing technology."

*It is essential that you understand the physical product and the physical inputs of the production function reflects the technical relationship.*

Here it must be known that when the production function is described as a function relationship between physical inputs and physical outputs then the concept of production thought as Flow Concept. **As a flow variable production refers to units of output per period of time.** For example, if the scale of production increases from 500 to 550 units, it does not mean that the production was 500 units in previous month and it would be 550 units in coming month. But this indicates that the scale of production increased by 500 units to 550 units.

The production function can be described statistically as –

$$Q = \psi (f_1 \dots f_m)$$

Q = Production

$$f_1 - \dots - f_m = m \text{ (Quantities of } m \text{ different inputs)}$$

The production function, as described above, only represents by **flow variables**. The product and the **input variables** are represented by numbers in time period.

**8.2 Fixed and Variable Inputs or Factors of Production**

A firm used various inputs for its production. To change the production quantity, it needs to change the inputs too. Some inputs can be changed temporarily. But possibility to change some inputs is in long

period. On the basis of this method, the factors of production or inputs can be classified in the following two parts –

- (i) **Fixed Inputs or Factors of Production:** The factors of production or fixed input cannot be changed temporarily. Some examples are – plants, buildings, administrative services, experienced worker etc.
- (ii) **Variable Inputs or Factors of Production:** The factors of production or variable inputs can be changed temporarily. Some examples are – raw material, workers etc.

*The fixed inputs and variable inputs can be classified by temporarily changed factors only.*

The fixed and variable inputs can understand by an example. If a firm publishes 1000 books per day and it needs to increase the publishing by 2000 books per day, then what would the firm do? Definitely, it needs more factors. But some factors like building, printing press etc., cannot be changed in a limited period of time. So to increase the publishing of books, this firm will take help from the variable inputs like labour, raw material etc. Thus in this example, printing press and buildings are fixed inputs while labour and raw materials etc. would be variable inputs. It must be known that the fixing of factors and changing of factors depend upon the time period.

### 8.3 Time Period

This must be remembered that the fixed or variable inputs depend upon those time period on which the inputs need to be changed as per change of the quantity of production. The economists classified this time period in two different parts –

- (i) **Short Period or Short Run:** Short run is defined as that period of time in which at least one or more than one factor of production or inputs are fixed and others are variable. So the quantity of production can be increased by the change of variable inputs in short period of time. In other words, there are both fixed and variable inputs in short period. So if the producer wants to increase his production in short period, he needs to increase the raw material and worker with fixed **machines** and plants as well as machinery. And if he wants to decrease its production in short period then he just needs to decrease the raw materials as well as the worker. But he cannot demolish the building or plant; no matter even if, there is no use of these inputs.
- (ii) **Long Period or Long Run:** Long period or long run is defined as that period of time in which all factors of production or inputs are variable. There are no fixed factors in long run. All factors are variables. In other words, the meaning of long run is that given period of time when we can increase or decrease all the factors.

### 8.4 Concepts of Output or Product

There are three main assumptions of production – (i) Total Product (ii) Average Product (iii) Marginal Product.

- (i) **Total Product (TP):** Total product of a variable factor is the maximum output produced by combining a given input of that factor with the fixed factor.

$$TR = AP \times L$$

or

$$TP = \Sigma MP$$

(Here TP = Total Production; AP = Average Production; L = Variable Factors of Input; MP = Marginal Production.)

**Notes**

(ii) **Average Product (AP):** The average production means the average product of a variable factor is simply the total product of the factor divided by the total units of the variable factor. By this we can get average product of every units of variable factors.

$$AP = \frac{TP}{L}$$

(Here AP = Average Product; TP = Total Product; L = Variable factors like total units of worker)

(iii) **Marginal Product (MP):** Marginal product of a variable factor is the change in total product resulting from the use of one more or one less unit of variable factor.

In other words, the Marginal Production is the measurement of the changes of total production due to the changes of quantity of variable factors.

$$MP = \frac{\Delta TP}{\Delta L}$$

(Here MP = Marginal Product;  $\Delta TP$  = Changes in Total Product;  $\Delta L$  = Changes in variable factors like labour.)

**Self Assessment**

**Fill in the blanks:**

1. The production function states the technical or physical relation between .....
2. The production function is the table (mathematical function), which represents the maximum .....
3. One fixed inputs in production means the ..... production in every time of frame.

**8.5 Laws of Production**

The law of production describes those methods which show the increase in production by technical point of view. The production can increase by many methods. We have already read while analyzing the nature of production function that the production can be increased by increasing variables in short run. So the process of changing the quantity of production when all the factors are stable and only the variable inputs are changed is called **Return to a Factor**. As opposite the production can be increased by increasing all the factors in long run. **Return to the scale** means the process to change the production by changing all factors and inputs. So, there are two laws of production:

**8.6 Returns to a Factor: Law of Variable Proportions**

If the use of variable inputs with the fixed inputs in a short run then it uses Law of Variable Proportions. **The law of variable proportion is the law which represents the changes in total production by using various averages of fixed and variable inputs and factors.**

When a factor of production is increased but all other factors are fixed, then it changes the averages of factors. Suppose that the factors of production are two – Land and Worker. Land is a fixed factor. Worker is a variable factor. Suppose you have two hectares of land. You grow tomato with the help of one worker. So the ratio of labour and land would be 1:2. If you increase the worker as 2 then this ratio would be 2:2. Means initially there is two hectares land for a worker and now it is per worker one hectare. Thus if there is the change of ratio of factors, the rates of quantity of production would change.

In economics, this nature is called Law of Variable Proportion. This law represents that the quantity of product initially increases in an average if the factors of production are changed but later the change in quantity of product is flat average and at last it goes downward. The traditional economists called this law as Law of Diminishing Returns. They mainly studied this in terms of farming. According to them if many workers would work in a fixed region of farm, the return would be less. But actually it is a general concept, which works on farming, industry, and real estate, etc. types of any production activity. In modern time, it is called Law of Variable Proportions. It can also be said the Law of Diminishing Marginal Product, Diminishing Marginal Returns or Diminishing Returns.

According to **Leftwich** – “The law of variable proportion states that if an input of one resource is increased by equal increments per unit of time while the inputs of other resources are held constant, total output will increase, but beyond some point the resulting output increases will become smaller and smaller.”

According to **Calvo and Waugh**, “The law of variable proportion states that if a variable quantity of one resource is applied to a fixed amount of other inputs, output per unit of variable input will increase but beyond some point the resulting increases will be less and less, with total output reaching a maximum before it finally begins to decline.”

### Assumptions

The main assumptions of Law of Variable Proportions are following –

(1) One factor of production is variable while others are fixed. (2) The all units of variable factors are equal or expertise. (3) There is no change in production technique. (4) The factors of production can be used in various averages. For example, one worker can be used to farm one hectare of land or 4 workers can be used to farm two hectares of land.



Notes

The Returns to Scale is called by change the process of production by changing all factors or numbers.

## 8.7 Conditions of Applicability or Causes of Application

The main reasons of Law of Variable Proportions are following –

1. **Indivisibility of Factors:** The main reason of law of variable proportions is that there are some factors in production which are undivided. It means there must be use of a unit of fixed input for producing a given quantity of product. The factor of production like machine is less used in primary stage of production. The more number of workers are needed to use its full volume. So in primary stage rather than using the variable inputs, the fixed are used more frequently. By using more number of variable inputs, the process based division of labour can be possible. This amplifies the work of variable inputs. The correlation between fixed and variable inputs gets optimum. Thus the marginal production increases and the total product also increases in increased rate.
2. **Change in Factor Ratio:** The main reason of law of variable proportion is that one factor is variable while the other factors are fixed in production. When the variable factors are used with fixed factors then the average changes in factors are decreased. A product is a result of using all the factors in production. When a unit of variable input works less than units of fixed inputs, then the marginal return starts decreasing of variable inputs.

For example, 5 workers work in ten hectares of land. Due to these 5 workers the land is used maximally for farming. In this condition, the ratio of land and service is 2:1. But if the number of

**Notes**

workers is increased to 10 then this ratio of land and service would be 1:1. This clarifies that one worker is less productive from one hectare of land against two hectares of land. So the marginal production will be low if the ratio of variable factor (worker) is less than the land (fixed factor).

3. **Imperfect Substitute:** According to **Ms. Joan Robinson**, the main reason of law of variable proportion is imperfect substitute of factors in production. A factor cannot replace another at all. If the replacement was possible then after using the optimum level of fixed factors, it could be increased by using variable factors. In this situation, the increase of production was possible in the first attempt. But this is not possible in the real life situation. So there is no replacement of one factor with another in production. So when the ratio of fixed and variable products is not matching then the marginal rate of product reduces for the changing factors.

### 8.8 Postponement of the Law

The postponement of law of variable Proportions can be following –

- (i) **Improvement in Technique of Production:** This law can be postponed by improving production techniques. In other words, using of improved techniques helps to increase the production and helps to decrease the production cost. By using this, law of variable proportion can be stopped.
- (ii) If the factors of production are fully changeable, means we can use one factor against another then this law can be stopped. In this situation, the factor cannot be fixed.

*The Law of Variable Proportions cannot be stopped permanently. This can be stopped for a limited period of time until a new technique emerges.*

### 8.9 Returns to a Factor – A Detailed Study of Different Situations

By using variable factors with fixed factors, there are three different situations of production:

#### Situation 1: Increasing Returns to a Factor

The returns to a factor is a state when total production increases in increasing ratio by using more numbers of variable factors used with fixed unit of fixed factors. In this condition, the marginal production of variable factors is increased. In other words, the marginal rate of production is less.

In the words of **Benham**, “Increasing returns to a factor states that as the proportion of one factor in a combination of factors is increased upto a point, the marginal productivity of the factor will increase.”

According to **John Robinson**, “Law of increasing return states that when an increasing amount of a factor of production is employed, it generally brings about an improvement in organization. As a result of it, units of the factor concerned become more efficient and to increase production, it will not be necessary to increase the physical quantity of the factor in the same proportion.”



*Did u know? The changing and fixing of factors depends upon time period.*

#### Illustration

Increasing Returns to a Factor can identify by Table 1 and Fig. 8.1.

Units of Labour	Units of Capital	Total Production	Marginal Production
1	1	4	4
2	1	10	$10 - 4 = 6$
3	1	18	$18 - 10 = 8$
4	1	28	$28 - 18 = 10$
5	1	40	$40 - 28 = 12$

From the above table we can know that when more units of labour are used with the fixed capital then the total product is increasing in increasing rate. The marginal production of variable factors is also increasing.

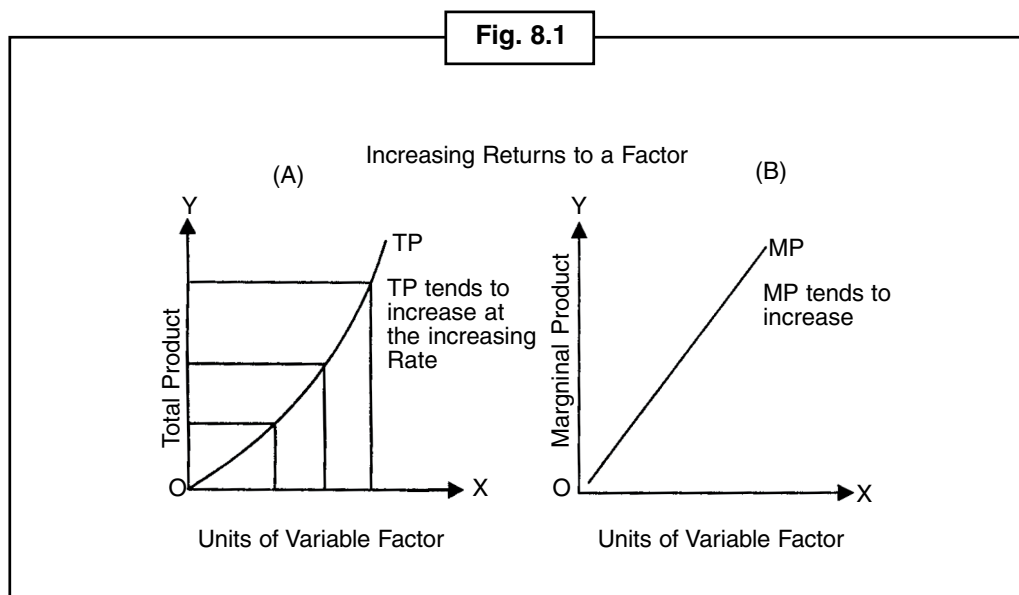

Figure 8.1 (A) states that the total production increases in increasing rate while Fig. 8.1 (B) indicates that the marginal production of variable factors is increasing.

### Causes of Increasing Returns to a Factor

The Causes of Increasing Returns to a Factor are follows –

- (i) **Under-Utilization of Fixed Factor:** The fixed factors of production like machine is used less in primary stage of production. For full use of this, there's needed more variable factors like labour. So the total production increases by using more numbers of variable factors in initial stage of production. In other words, the marginal production of variable factors is increased. For example, to make cloth, a small plant is used. The size of plant would stable in short run. To get maximum production, there is need of 5 workers in this plant. If there are only 1 or 2 workers work in this plant, then the full use of this plant would not happen. But when gradually the number of workers would increase by 5 then production will also increase to its optimum level. By this, the marginal production of every unit of worker would increase and thus, the total production will also increase.



**Notes**

- (ii) **Increase in Efficiency:** According to **Adam Smith, Marshall and Robinson**, using of law of variable proportions can increase the efficiency in various modes of production. The reason behind this is that the possibility of division of labour and speciality increases by increasing units of law of variable proportions. Efficiency gets its optimum by division of labour and this maximizes the production ratio. According to **Robinson**, if the factors of production get specialized means one factor only perform a single task then the expenditure of training, time and machinery would be very much less. Due to this saving, the law of increasing returns to factor will happen.
- (iii) **Better Coordination between the Factors:** The use of increased number of variable factors make better coordination between fixed and variable factors until the fixed factors of production are used. Due to this, the total production increases by increasing rate.

**Limitations**

The fixed inputs get its minimum use in terms of variable inputs in the primary stage of production, so when the fixed factor gets its maximum use by using more quantity of variable factors, the law of increasing returns to factor amplifies. But this condition is not permanent. If increasing returns were operative without limitations indefinitely, the world could be fed from a kitchen garden or a flower pot simply by adding enough labour and capital to the fixed land. Due to this there would be no food problem in any parts of world. But the law of increasing returns cannot be applied after a limit. After a time, the marginal production cannot increase. The limit of increasing return is limit of a factor of production. There would be a condition when every unit of variable factor correlates with less units of fixed factor and production occurs. Due to this the marginal production gets less for extra units of variable factors.

**Situation 2: Constant Returns to a Factor**

Constant returns to a factor means there is no increment in marginal production by using more units of variable factors. In this situation, marginal production stabilizes. And due to this, the total production increases in equal rate.

According to **Hansen**, “Constant returns to a factor occurs when additional applications of the variable factor increases output only at a constant rate.”

**Illustration:** The law of Constant Returns to a Factor can be described by Table 2 and Fig. 8.2

<b>Table 2: Constant Returns to a Factor</b>			
<i>Units of Labour</i>	<i>Units of Capital</i>	<i>Total Production (in metre)</i>	<i>Marginal Production (in metre)</i>
6	1	52	12
7	1	64	12
8	1	76	12
9	1	88	12
10	1	100	12

By Table 2 we can understand that the total production increased gradually as more labour is added with fixed units of capital means the marginal production is constant for variable factors.

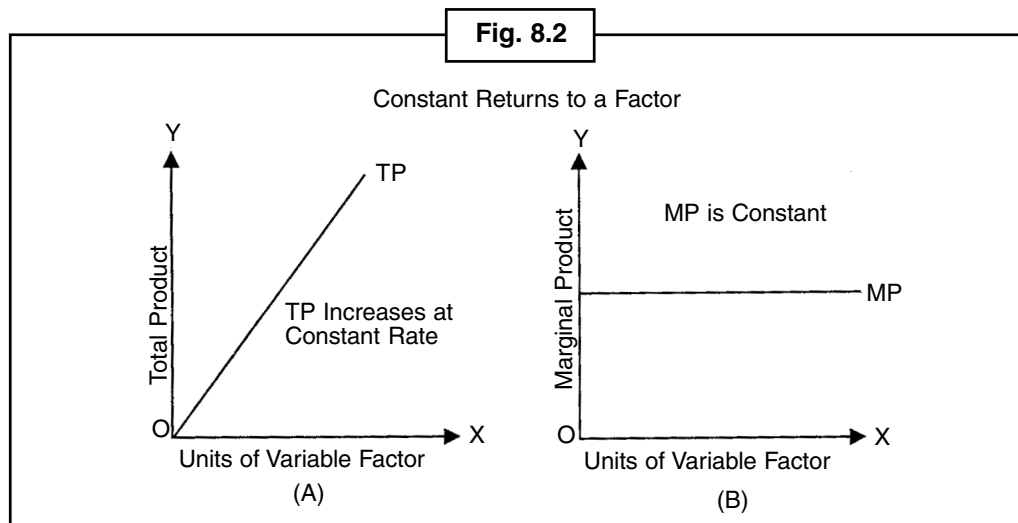

Above Fig. 8.2 (A) indicates an uprising TP curve which suggests that total production is increasing by a constant rate. In Fig. 8.2 (B) the MP curve which is parallel to axis OX indicates that the marginal production of variable factors is constant.

### Causes of Constant Returns to a Factor

These are the following causes of constant returns to a factor:

- (i) **Optimum Utilization of the Fixed Factor:** When production gets increased by using variable factors then a time comes when the fixed factors have been utilized optimally. In this case, the marginal production is up to the variable factors and stable too.
- (ii) **Ideal Factor Ratio:** When the variable and fixed factors are used to their optimum level then it gives constant returns. In this situation, the marginal production of factors stabilizes in its maximum value.
- (iii) **Most Efficient Utilization of the Variable Factor:** When we use more units of variable factors along with fixed factors then a time comes when we can do maximum division of labour. By this, the variable factors like labour can be used in very efficient way and its marginal production gets stable in its maximum level.

### Situation 3: Diminishing Returns to a Factor or Law of Diminishing Returns

The Diminishing returns to a factor or law of diminishing returns is the situation when the total production increases in falling rate if fixed factors or the variable factors with fixed units are used. In this situation, the marginal production of variable factors gets low. In other words, **the cost of marginal production is increased.**

According to Marshall, "An increase in the amount of capital and labour applied in the cultivation of land causes, in general a less than proportionate increase in the amount of produce raised unless it happens to coincide with an improvement in the art of agriculture."

According to Boulding, "As we increase the quantity for any one input which is combined with fixed quantity of other inputs, the marginal physical productivity of the variable input must eventually decline."

Notes

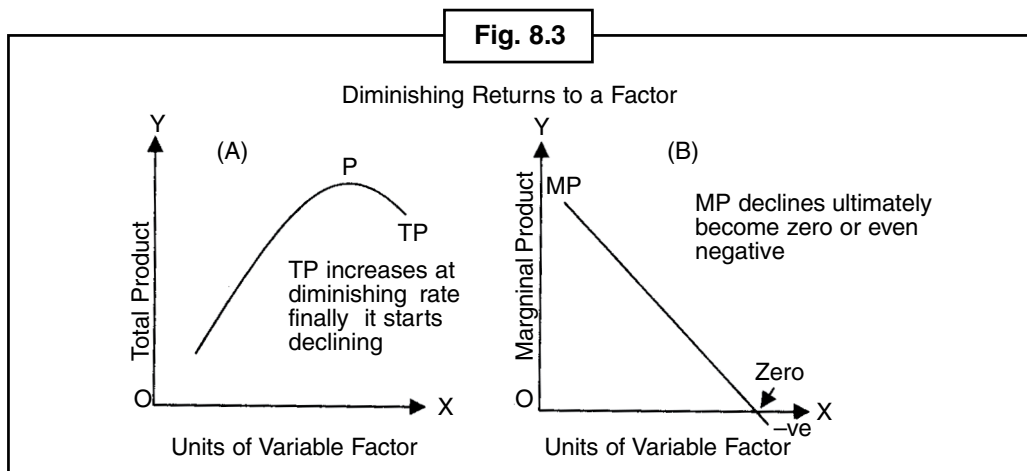

Illustration: Table 3 and Fig. 8.3 indicate the diminishing returns to a factor.

Table 3: Diminishing Returns to a Factor			
Units of Labour	Units of Capital	Total Production	Marginal Production
13	1	110	10
14	1	118	8
15	1	124	6
16	1	128	4
17	1	128	0
18	1	126	-2

By above table we can get that as the fixed capital uses with more units of labour, then the total production increases in its decreasing rate and it falls after 5<sup>th</sup> unit. The marginal rate of variable inputs means labour is decreased. It can be zero or negative after a period of time.

The Fig. 8.3 (A) indicates that the total production is increasing in a decreased rate and it starts falling after point A. In Fig. 8.3 (B), the down MP curve indicates that the marginal production of variable inputs is decreasing. **This law can be stopped by rectifying the production technique.**



Self Assessment

Multiple choice questions:

- The changes and stability of factors depends upon ..... of time.
  - period
  - movement
  - curve
  - boundary
- Some variable inputs are Raw Material, ..... services etc.
  - workers
  - servicemen
  - labour
  - none of these

6. The variable factors of production are the factors by which the quantity can be changed in .....
- (a) long run                      (b) short run                      (c) middle run                      (d) none of these
7. The changes in variable factors in short run can increase the production .....
- (a) short                              (b) increment                      (c) marginal                      (d) none of these

### 8.10 Causes of Diminishing Returns to a Factor

These are the following causes of diminishing returns to a factor:

- (i) **Fixity of Factors:** The main cause to apply of this rule is that at least one factor of production is fixed. When this fixed factor is used with variable factors then the ratio of it declines with the variable factors. So when a unit of variable factors works with low constant fixed factor then the marginal production of variable factors gets decreased.
- (ii) **Imperfect Factor Substitutability:** According to **Ms. Joan Robinson**, the main reason of law of diminishing returns to a factor is imperfect substitute of factors in production. A factor cannot replace another at all. So when we do the optimum uses of fixed factors, then we cannot take another factor inspite of optimized fixed factor. This imbalances the variable and fixed factors and the marginal production gets decline for variable factors.
- (iii) **Poor Coordination Between the Factors:** By increased using of variable factors with fixed factors, the **ideal factor ratio** decreases. This affects badly to the ratio of variable and fixed factors and the marginal production of variable factors gets down. This coordination is so poor that it affects the total production level. Due to this, the marginal production of variable factors can be zero or can be negative.

### **Importance of the Law**

The law of diminishing returns is a very important law of economics. The importance is indicated by the following –

- Basis of the Theory of Population:** The theory of population of **Malthus** is based on this law. According to **Malthus**, the increment of food is less than population. This is just because the law of diminishing factors gets involved in farming.
- Basis of the Theory of Rent:** The theory of rent of **Ricardo** is also based on this law. The first unit of production on land by labour and capital is more than the second unit. The difference of this unit of production is called rent.
- Based on the Theory of Distribution:** The theory of distribution is also based in this law. As a factor of production uses in its maximum, the **marginal productivity** gets low and the income also declines.
- Based of Equilibrium Production:** A producer can know the quantity of equilibrium production by the help of this law. The equilibrium production happens on that point where the increased level of marginal production is equal to marginal income.

### 8.11 Three Stages of Production

Under this law of diminishing factors, the economists have given three stages of production. These are (i) **Increased level of Returns**, (ii) **Equal level of returns** and (iii) **Negative level of returns**. This is described by Table 4 and Fig. 8.4.

Notes

Table 4: Three Stage of Production				
Units of Land (in hector)	Units of Labour	Total Production	Marginal Production	Stages
1	1	2	2	<b>First Stage:</b> MP increases, TP increases by increasing rate
1	2	5	3	
1	3	9	4	
1	4	12	3	<b>Second Stage:</b> MP Decreases, TP increases by decreasing rate
1	5	14	2	
1	6	15	1	
1	7	15	0	
1	8	14	-1	<b>Third Stage:</b> MP is negative, TP decreases

**Note: End of Stage One is Start of Stage Two: End of Stage Two is Start of Stage Three.**

The Table 4 clarifies that as the inputs of variable factors increase in the **first stage**, the marginal production increases. Thus, TP increases in increasing rate.

**In second stage**, the marginal production decreases by inputs of variable factors. Thus, TP increases in decreasing rate.

**In third stage**, the marginal production gets negative by inputs of variable factors. Thus the total production gets declined. In Fig. 8.4, by using variable inputs of OL units, MP increases. This

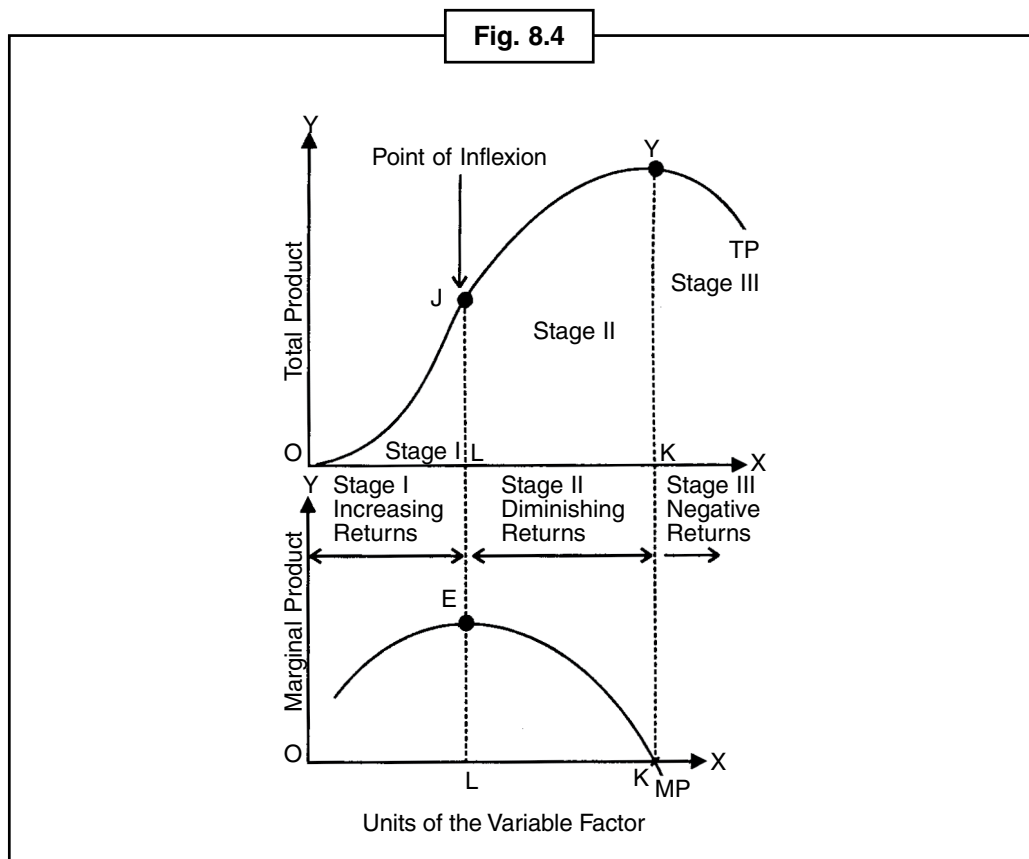

is the stage of increase level of returns. TP increased with increasing rate of MP from O to J. The MP decreases in between the units L and K of variable factors. This is the stage of decrease level of returns. TP decreased with decreasing rate from J to T. When more than K units of variable factors work then the marginal production gets negative and thus TP is decreased. This is the stage of negative level of returns as shown in the right side of T point on TP curve. By this TP is declined. This is negative level of returns as shown in right side of T point of TP curve.

## 8.12 Significance of the Stage of Production

**Do you stop the production in its first stage as a producer?**

**No.** Because by using per extra units as law of variable proportions, the marginal production is always increasing.

**Do you want to get production in the third stage as a producer?**

**No.** Because by using per extra units as law of variable proportions, the total production is getting decreased (marginal production is negative). In fact, the loss in total production or total income is really foolish and it is more costly when we put extra units as law of variable proportions.

So we reach in a decision that a producer would want to produce goods on **second stage** only. In the technical language, **it means that a producer is in equilibrium stage in second level when marginal production is decreasing but positive.**



*Task* Give your opinion on the three stages of production.

## 8.13 Stage of Rational Decision

To get maximum level of profit, a full contestant firm will use its production in the **second stage**. The reason behind this is –

However, the ratio proportion is increasing by **variable inputs** in the **first stage**, but the fixed factors are used in their minimum level. So as soon as the production increases, the marginal production also increases or marginal cost decreases. If support AR is fixed cost means MR is stable, it means the gap between MC and MR is widening. The widening gap between MC and MR indicates the increased profit (when  $MR > MC$ ). A rational producer will never stop his production in this profit level.

*First and third stage are unimportant in profit view. The main reason is that in this situation a firm can never be in a stable condition.*

A rational producer will never produce goods in the third stage because in this stage the total production is getting low. In the words of Ferguson, **“Even if units of the variable inputs are free, a rational producer would not employ them beyond the point of zero marginal products because their use entail a reduction in total output.”**

In summary, a wise firm will always produce goods in **second stage**, when diminishing return starts. A full contestant firm would never produce in **first and third** stage and will only produce goods in second stage. The real quantity of production in stage two depends upon the cost of production and the factors of production. The equilibrium will happen where extra income (MR) and extra cost (MC) are equal.

**TP, AP and MP: A Diagrammatic Presentation:** The TP, AP and MP curve look flat due to the division of labour time. The curve AP is going till point H and then falls (but it is positive till TP is positive). MP highs till point G, gets zero in point I and after that gets negative. When AP curve moves up then MP curve is more above it; when AP curve drops then MP curve is just below it and when AP curve is at its maximum point (like point H) then  $MP = AP$ .

Notes

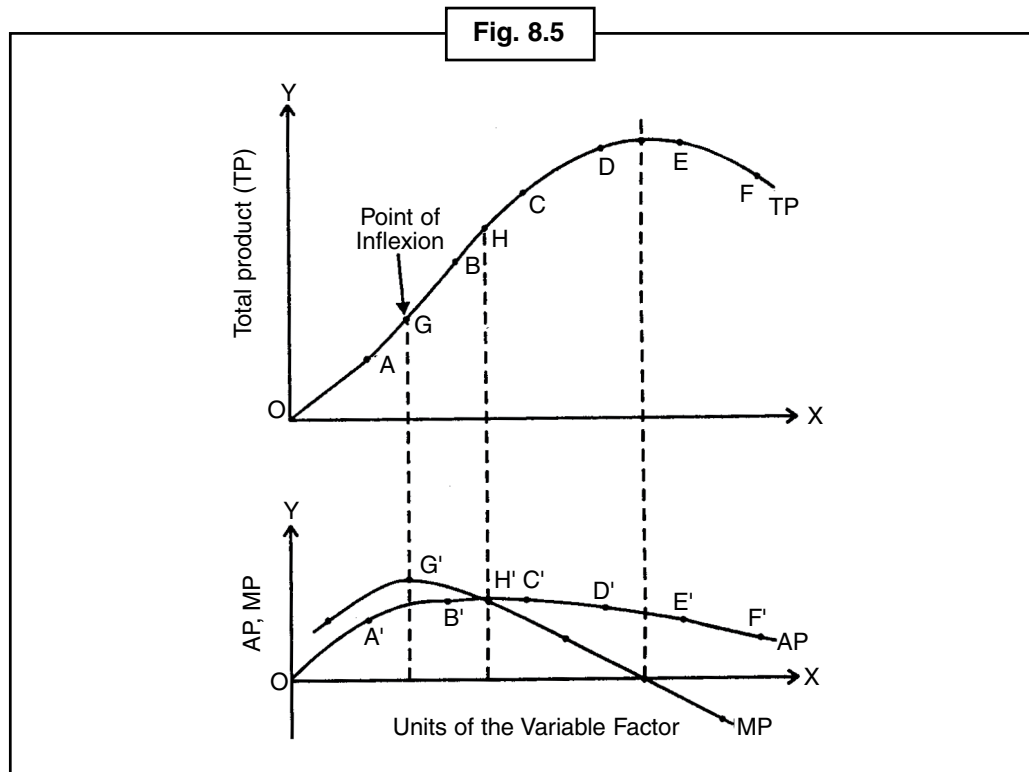

**Relation Between Total Production and Marginal Production**

- (1) When marginal production increases then total production increases in increasing rate.
- (2) When marginal production is constant then total production constantly produce goods.
- (3) When marginal production decreases then total production decreases in decreasing rate.
- (4) When marginal production gets negative then total production decreases.

**Relation Between Average Product and Marginal Product**

- (1) When marginal production is more than average production then average production increases.
- (2) When marginal production and average production are equal, the average production is maximum.
- (3) When marginal production is less than average production then average production decreases.
- (4) The marginal production can be zero, positive or negative but average production is always positive.
- (5) According to figure, MP curve is always in the left side of AP curve.

**Point of Inflexion**

This is the point where the slope of TP changes. In Fig. 5, this point is G in TP curve. TP is increasing upto this point. After this point, TP is increased but in decreasing rate.

This is the point which comes at the coincide of first stage (because in this point, MP is stable) or this is the point which indicates the beginning of second stage (because in this point, MP decreases).

## 8.14 Returns to Scale

The returns to scale describes those behaviours of production which come by changing all the inputs in a similar way. This is a long term conception.

All the factors are variable in long run. No factors are fixed so we can change the production scale by changing same rate of changes in all the factors.

According to Koutsoyiannis, "The term returns to scale refers to the change in output as all factors change by the same proportion."

A production of a product can increase by increasing all factors in similar ratio or different ratios in long run. Generally, the law of return to scale is the increased production rate by increasing all factors in a similar ratio. This view in production is called Returns to Scale.

Suppose that primary production scale is –

$$P = f [L, K]$$

If both the factors of production like labour (L) and capital (K) are increased in similar proportion (m) then the total production would be  $P_1$ . So,

$$P_1 = f [mL, mK]$$

- (1) If  $P_1$  increases like the ratios of all the factors increased means  $\frac{P_1}{P} = m$ , then it would be called Constant Returns to Scale.
- (2) If  $P_1$  changes in decrease ratios of all the factors means  $\frac{P_1}{P} < m$  then it would be called Diminishing Returns to Scale.
- (3) If  $P_1$  changes in increasing view like the ratios of all the factors increased means  $\frac{P_1}{P} > m$  then it would be call Increasing Returns to Scale.

This Returns ro Scale can be described by Table 5.

Units of Labour (1)	Units of Capital (2)	Percentage increase in Labour and Capital (3)	Total Production (4)	Percentage increase in Total Production (5)	Returns to Scale (6)
1	2	–	10	–	Increasing
2	4	100%	30	200%	
3	6	50%	60	100%	
4	8	33%	80	33%	Constant
5	10	25%	100	25%	
6	12	20%	110	10%	Decreasing
7	14	16%	120	9%	
8	16	14%	125	4%	



**Notes**

(i) The percentage increment of labour and capital in Table 5 is done by following –

$$\begin{aligned} \text{Percentage change in labour} &= \frac{2-1}{1} \times 100 = 100\% \\ &= \frac{3-2}{2} \times 100 = 50\% \text{ etc.} \end{aligned}$$

Thus, the percentage of capital calculates

$$\begin{aligned} &= \frac{4-2}{2} \times 100 = 100\% \\ &= \frac{6-4}{4} \times 100 = 50\% \text{ etc.} \end{aligned}$$

This clarifies that the percentage changes in labour and capital is equal to each other because there is equal changes in their average.

(ii) The percentage changes of total production is described in Table 5 as follows –

$$\begin{aligned} &= \frac{30-10}{10} \times 100 = 200\% \\ &= \frac{30-10}{10} \times 100 = 100\% \text{ etc.} \end{aligned}$$

### 8.15 Three Different Situations of Returns to Scale

There are 3 different stages to returns to scale:

- (i) **Increasing Returns to Scale**
- (ii) **Constant Returns to Scale**
- (iii) **Diminishing Returns to Scale**

#### (i) Increasing Returns to Scale

Increasing Returns to Scale occurs when a given percentage increase in all factor inputs (in some constant ratio) causes proportionately greater increase in output. So if the increase of 10% to the production factors labour and capital and it increases the production by 15%, then it is called Increasing Returns to Scale.

Figure 8.6 indicates that the increment of 10% in production factors increases the production by 15% and if increases more by 15% then the production increases by 25%. Thus the law of Increase Returns to Scale happens when average increment of production is more than the average in production factors.

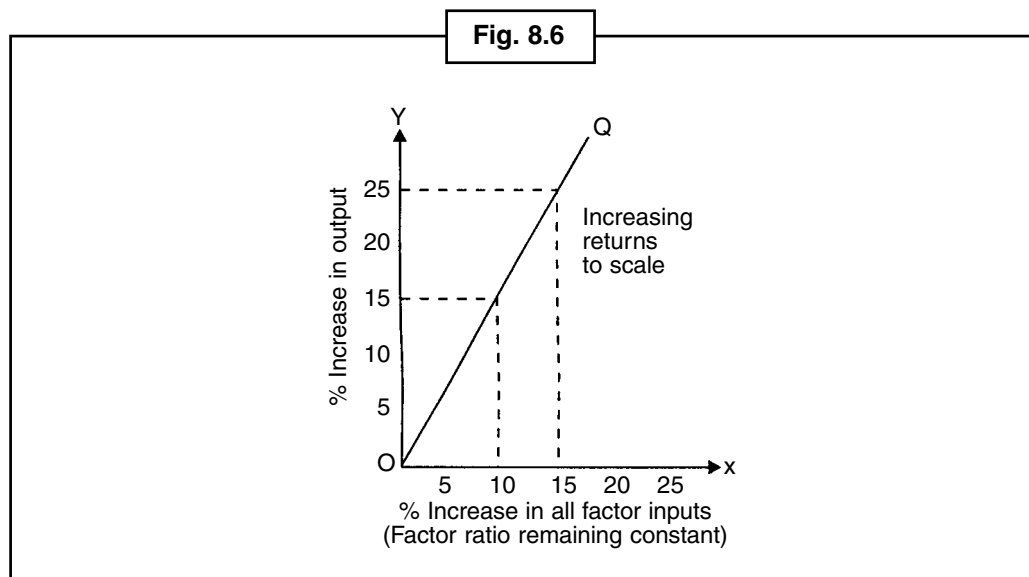

The main reason of increasing returns to scale is it gives opportunity to economies cost like division of labour and specialization of work. Due to this, this return gives more production than the use of production factors. Savings are internal because it only relates to the size of the firm.

### (ii) Constant Returns to Scale

Constant returns to scale occurs when a given percentage increase in all factor inputs (in some constant ratio) causes equal percentage increase in output. According to this law, suppose there is an increment of labour and capital by 10%, then the production will rise by 10%.

In Fig. 8.7, OQ curve indicates constant returns to scale. The figure shows that the production percentage is up by 10% by increasing 10% to all the percentage of factors. Thus the production percentage increases by 20% if 20% increase in the parentage of production factors. This clarifies that the production percentage increases if the ratio of production factor increases. So, the OQ line shows constant returns to scale by making 45 degree angle to point O.

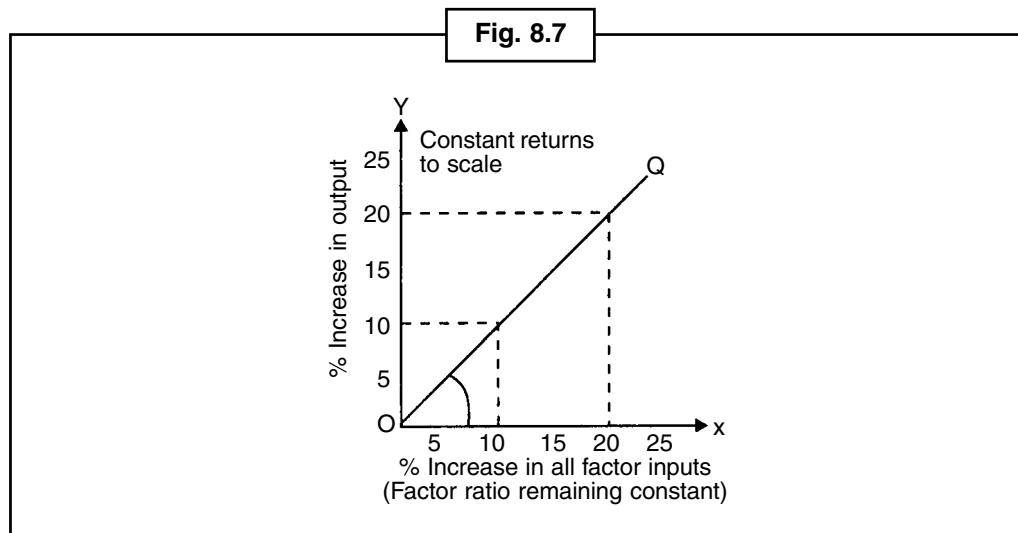

To use this law in a fixed stage of production, the profit and loss are equal to each other. This is known as Homogenous Production Function in terms of mathematical representation. In this function, if labour and capital are increasing by a ratio, then the production percentage would be increased by that ratio.

### (iii) Diminishing Returns to Scale

Diminishing returns to scale occurs when given percentage increase in all factor inputs (in some constant ratio) causes proportionately less increase in output.

If the production is decreasing 10% by increasing 15% to its factors, it is called Diminishing Returns to Scale. Figure 8.8 indicates the diminishing returns to scale. OQ line indicates that the production is increasing 10% by increasing 15% of the factors and it increases 15% by increasing 25% of the factors. This indicates the decreasing of diminishing returns to scale.

Notes

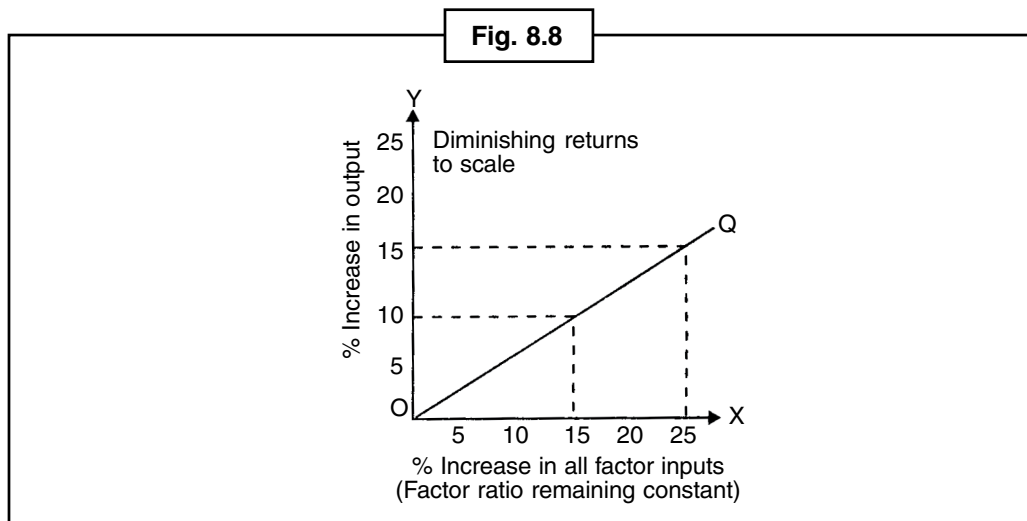

To use the diminishing returns to scale is that diseconomies are more than the economies.

### Self Assessment

State whether the following statements are True/False:

8. Equilibrium production occurs on that point where the increased marginal cost is equal to marginal income.
9. When marginal production increases then the total production increases in increasing rate.
10. When marginal production is less than average production then average production decreases.
11. When marginal production is positive then the total production increases.
12. The scale which produces constant scale of factors is known as Homogenous Production Function in terms of mathematical representation.

### 8.16 Economies of Scale or Causes of Increasing Returns to Scale

Increasing returns to scale occurs due to diseconomies. **Economies of scale refer to the situation in which increasing the scale of production reduces the unit cost of production or raises output per unit of the factor inputs.**

According to Koutsoyiannis, "Returns to scale is only one part of the economies of scale. Returns to scale is technical, while economies of scale includes the technical as well as monetary economies."

Economies of Scale can distinguish into two parts –

- (a) **Internal Economies of Scale:** This economy happens due to increment of shape and size of a firm and it only relates to that particular firm.
- (b) **External Economies of Scale:** This economy happens due to increment of shape and size of an industry or firms and it relates to all the firms.

### 8.17 Internal Economies

When firm expands its scale of production, it qualifies for more economies. These economies are called **Internal Economies**. The increasing returns of scale is due to internal economies. **Internal economies are those economies which are firm specific.** These economies are received by those firms who increase its scale of production and increase the production level. These economies are called internal because the firms which do not increase its scale of production cannot qualify for these economies.

According to Cairncross, "Internal economies are those which are open to a single factory or a single firm independently of the action of other firms. They result from an increase in the scale of output of a firm and cannot be achieved unless output increases."

Types of Internal Economies – Koutsoyiannis has divided this into two parts –

(i) Real Economies and (ii) Pecuniary Economies

#### **(i) Real Economies**

Real economies are those which are associated with a reduction in the physical quantity of inputs, raw materials, various types of labour and various types of capital.

#### **What are Real Economies?**

*Real economies are those economies which reduce per units of production costs.*

### 8.18 Summary

- In the initial stage of production, the less use of variable inputs with respect to fixed inputs creates the less use of fixed inputs, so if the maximum use of variable inputs creates the maximum use of fixed inputs, then law of Increasing Returns of Scale applies. If increasing returns are operative without limitations, the world could be fed from a kitchen garden or a flower pot simply by adding enough labour and capital to the fixed land.

### 8.19 Keywords

- **Production Function:** Quantity of Production
- **Short Period:** Short Period
- **Increasing Returns:** Increasing Production
- **Diminishing Returns:** Diminishing Production

### 8.20 Review Questions

1. What do you mean by Production Function? Describe.
2. Give causes of Increasing Returns of Factors.
3. Give the details of three stages of production.
4. What do you mean by increasing returns to scale? Clarify it.

Notes

**Answers: Self Assessment**

- |              |               |           |          |
|--------------|---------------|-----------|----------|
| 1. Technical | 2. Production | 3. Units  | 4. (a)   |
| 5. (c)       | 6. (b)        | 7. (b)    | 8. True  |
| 9. True      | 10. True      | 11. False | 12. True |

**8.21 Further Readings**



*Books*

1. **Microeconomics**—*David Basenco and Ronald Brutigame, Wiley India, 2011, PBK, 4th Edition.*
2. **Microeconomics: An Advanced Treatise**—*S. P. S. Chauhan, PHI Learning.*
3. **Microeconomics: Behaviour, Institutions and Evolution**—*Sampool Bowels, Oxford University Press, 2004.*

## Unit-9: Theory of Cost and Revenue

### CONTENTS

Objectives

Introduction

- 9.1 Concepts of Cost
- 9.2 Costs in the Short Run
- 9.3 Total Cost
- 9.4 Relation Among Total Cost, Total Fixed Cost and Total Variable Cost
- 9.5 Average Cost
- 9.6 Why is the Short Run Average Cost Curve 'U' Shaped?
- 9.7 Marginal Cost
- 9.8 Why is MC Curve 'U' Shaped?
- 9.9 Relation between Average Cost and Marginal Cost
- 9.10 Relationship of Different Cost Curves in the Short Period
- 9.11 Relationship between Cost Curves and Productivity Curves
- 9.12 Costs in Long Run
- 9.13 Long Run Total Cost – LTC
- 9.14 Long Run Average Cost Curve or Envelope Curve
- 9.15 Long Run Marginal Cost Curves
- 9.16 Modern Theory of Cost Curves
- 9.17 Long Run Marginal Cost Curves
- 9.18 Technical Change: The Very Long Run
- 9.19 Summary
- 9.20 Keywords
- 9.21 Review Questions
- 9.22 Further Readings

Notes

## Objectives

After studying this unit, students will be able to:

- Learn the concepts of cost.
- Study Average cost.
- Learn Marginal costs.
- Understand the long-term costs.

## Introduction

The decision of a firm to maximize its profits, depends on the cost of production and revenue. In this unit we will study the principles of cost. Generally, refers to a firm's production cost which is taken from the monetary costs, which is carried out in relation to the production of the commodity. The colloquial language of the monetary expenditure on these inputs is called the cost of production. It must be done on the output of the monetary costs, the costs of a variety of perception. Costs related many assumptions are monetary costs, opportunity costs and social costs.

## 9.1 Concepts of Cost

### 1. Monetary Cost

To produce an object has to spend the money as currency that is called the monetary cost of item. Generally speaking language 'Cost' is used for monetary cost.

According to **J.L. Hanson**, "**The money cost of producing a certain output of a commodity is the sum of all the payments of the factors of production engaged in the production of that commodity.**"

— **J.L. Hanson**

The following expenses are included in the monetary costs—(i) Workers wages paid. (ii) Any interest charged for loans (iii) The fare paid for standby (iv) Spending on raw materials and machines (v) Insurance (vi) Tax (vii) Driver power, light, and spending on fuel (viii) The expenditure in transport.

### 2. Real Cost

It is the actual cost of the item to produce an object that has mental and physical effort and sacrifice, real cost refers to the pain, the discomfort involved, in supplying the factors of production by their owners.

In the words of **Marshall**, "The exertions of all the different kinds of labour that are directly or indirectly involved in making it (a commodity) together with the abstinences or rather the waiting required for saving the capital used in making it, will be called the real cost of production of commodity."

— **Marshall**

In short, the actual costs incurred for the production is expressed in the form of hardship, sacrifice and effort. For example, a clay potter making a toy has to work for eight hours, and then eight hours of labour must be the actual cost of the toy. The perception of the actual cost is a **Subjective** perception. It is not possible to measure it. The importance of this notion is not so today.

### 3. Accounting or Business Cost

Accountancy cost means that the cash payments, firms instrument input, and depreciation expense as the non-mains input, and the other is from the book on other entries.

In the words of Nicholson, "Accounting cost refers to out of pocket expenses, historical costs, depreciation and other book keeping entries."

– Nicholson

**Out of Pocket** expenditure under this definition means instant payments have to be outsiders. The **Historical Cost** of an asset, the actual cost of an asset which is actually the time of purchase. The books are written in cost accountancy. That is also called **Actual Cost, Acquisition Cost, Explicit Cost or Direct Cost.**

#### 4. Opportunity Cost

Economic costs are more important notion of opportunity cost. We know the cost of something means those inputs whose prices are used for the production of that commodity. This is because the value of an input is scarce or limited. If we use an input to the production of a commodity charge, then it is not available for the production of any other commodity. The cost of production of a commodity as a result of the production has to sacrifice a second best option as measured. When we spend a certain amount of money on the production of an object, the amount of money, the cost is incurred, But rather as a result of the production. The options must be abandoned or discarded as a measure of their value. As a result of the production of a commodity has to give several options, then it abandoned **Second Best Opportunity** or option value. It is called the opportunity cost. **The Opportunity Cost is the Cost of Next-best Alternative Foregone. It is also called alternative costs.**

Suppose a farmer in a field can grow both crops of wheat and gram. If a hectare farm produces only wheat, he has to sacrifice gram. If the amount of movement of the gram price is ₹ 1,000 then same will be the amount of movement of the wheat price. Price of the gram which farmer has to sacrifice for producing wheat is called opportunity cost. Thus, for a firm to be used for the production of income is the opportunity cost of resources, this means that you cannot use their second best result of the experiment has to be discarded.

According to **Leftwich**, "Opportunity cost of a particular product is the value of the foregone alternative products that resources used in its production, could have produced."

– Leftwich

According to **Ferguson**, "The alternative or opportunity cost of producing one unit of commodity X is the amount of commodity Y that must be sacrificed in order to use resources to produce X rather than Y."

– Ferguson

 *Illustration:* The concept of opportunity cost can be explained by Fig. 9.1.

It can be concluded from this figure that if a certain amount of resources X - object and Y - object is used to produce both are produced in the following manner (i) Y-item 12 units and X the object is not a single entity, (ii) X, 6 units, and state of the object - the object is not a single entity.

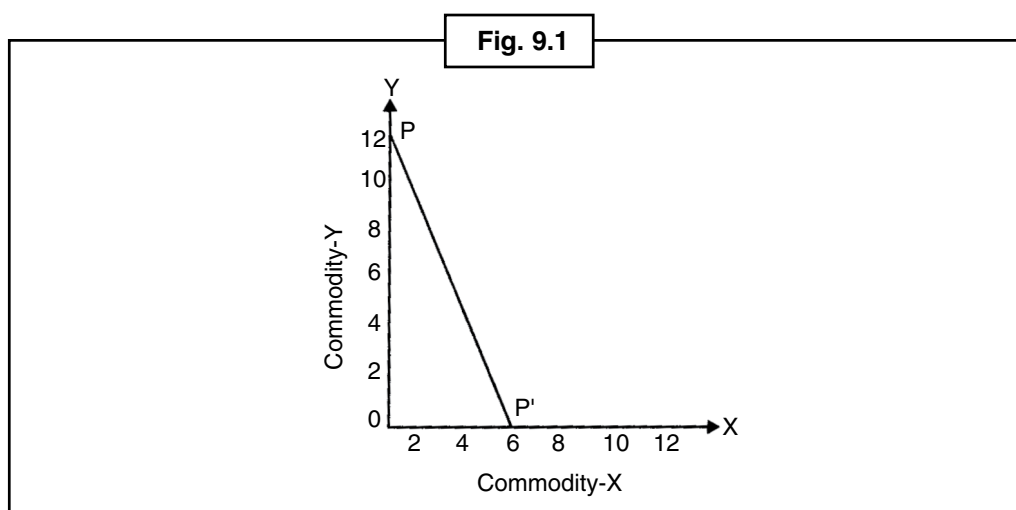



**Notes**

(iii) PP' to be revealed by the line X-object and Y-various combinations of the object. This line is known as the X-object to the output, Y has to sacrifice the opportunity to produce the object. The same as the Y, X-object is called opportunity cost. It can be concluded from the figure that, X-the opportunity cost of one unit of item is  $\frac{12}{6} Y = 2Y$ . This means that the amount of the means of production may produce a unit of the X object. The same quantity of commodity Y may produce 2 units. Hence Y-object, such as X- item 2 is the opportunity cost. Similarly, X-object, as the Y-th opportunity cost of one unit of item is  $\frac{6}{12} = 0.5 Y$ . This means the amount of the means of production using the Y-th object is to produce a unit of the same from the Y-0.5 unit of the commodity can be produced. Therefore X, the Y-th opportunity

cost of the object is 0.5. In short, an instrument to be used in a specific job opportunity cost is the price of the instrument, which can be received from its second best option. We should also note that the undercurrent of the concept of **opportunity cost is not money payments but sacrificed opportunities or alternatives.**

For example, a firm that uses its own proprietary and self that means do not pay for its own means, but they are also opportunity costs, because their extracts are used to produce one object to another object that could have been produced by their assistance, has to be discarded. Self-mastery and self-contained cost is the cost of resources used. In contrast to outsiders by the firm and their services are paid cash for goods are called **Explicit Costs. The opportunity cost includes both explicit costs and implicit costs.**

**You Must Know**

*Both explicit and implicit cost are included in, the opportunity cost of production. The opportunity cost of an object to produce the opportunity to achieve the object, the value of any other commodity production opportunity is discarded.*



Notes

The real cost is the cost to their fulfillment by the owners of the means of production; suffering, sorrow, trouble, etc. have to bear.

**5. Economic Cost**

In economic analysis, the economic cost, accountancy costs and use of their own proprietary tools mean all costs are covered.

**Economic costs may be defined as those monetary payments a firm must make to those outsiders who supply resources and non-expenditure payments of self-owned and self-employed resources which they could have earned in their best alternative opportunities.**

Therefore, only the **Explicit Costs** are included in cost accountancy. In contrast, the Economic Costs include both **Explicit Costs** and **implicit Costs**.

The notion of economic cost can be clarified with the example of cost required to get education in college in a year. Suppose, the fee given to college to get education in one year including hostel cost and other expenses is ₹ 6000. In other words, **Accountancy Cost of education in a year in a college is ₹ 6,000.** But the economic costs of the additional monetary costs is included the income, for a student to study in college identifiable time and money by using an alternative work could earn. If it is not then any college work throughout the year 5000 could earn. College of ₹ 6,000 to be spent on education and the bank rate of 5 per cent per year in the form of interest could have ₹ 300. Therefore economic cost to get education in a college in a year will be **(Monetary Costs + Discarded Earnings) leaved Interest + 6,000 + 5,000 + 300 = ₹ 11,300 will be.** The economic costs include both the accountancy costs and the opportunity cost, therefore, an object that reflects the true costs of production.

**The Economic Cost is Different from Accountancy Costs**

*High costs are only included in cost accountancy. In contrast, the economic costs, explicit costs and implicit costs are both included.*

## 6. Social Cost

Social cost is the cost which entire society has to pay for an economic activity. Each society's economic organization is associated with many types of social costs, such as **Air Pollution** and noise, etc. which are not taken into account while determining the price of production. Social costs of a firm or individual opportunity cost is the opportunity cost of the entire society.

### Social Cost is Different from the Individual Cost

*All over the social costs borne by society, such as air pollution, water pollution, noise pollution has on society all around. Only personal cost burden is borne by the individual firm which produces the object.*

According to Dictionary of Modern Economics, "Social cost of a given output is defined as the sum of money which is just adequate when paid as compensation to restore to their original utility levels all who lose as a result of the production of the output."

– Dictionary of Modern Economics

**Social cost is the cost incurred by the whole society for producing a commodity.** For example, during the production of the fabric, the smoke which is generated from textile mills as a result of this the people have to spend more on washing their clothes. Contamination of air results a poor health as a result people have to spend money on therapy. No private firm would have all these expenses. The burden is borne by society itself, so called social cost of this type of expenditure. In other words, the social cost of any goods or services incurred by the producers of the commodity or service costs (private costs) And those imposed by the negative externalities or external costs are included.

## 7. Private Cost

Private costs are the costs which a firm has to pay to produce an object. It includes both explicit costs and implicit costs.

According to Miller, "Private costs are the costs incurred by the firms of the individual producers as a result of their own decision." For example, the money that a textile making firm spends in terms of raw materials, wages, rent, electricity, etc. is called personal cost. The main cause of getting difference between social costs and individual costs is external cost. External costs are those costs which those people have to bear who feel negative externalities as a result of producing a product. In Short private cost = social costs – external costs.

## 8. Explicit Costs

A firm has to take many inputs in terms of buying or rent.

The outsiders who fulfil labour, raw materials, fuel, transport, etc., of a firm, the firm has to pay money for them. This money which is given to outsiders by the firm is called explicit costs.

According to Leftwitch, "Explicit costs are those cash payments which firms make to outsiders for their services and goods."

– Leftwitch

Wage offered by the firm, rough raw expenditure payments, **Depreciation** expenditure on interest charged on loans, payment etc. are called explicit costs. This is also called **Absolute Costs, Production Costs**, or the **Actual Cost**.

## 9. Implicit Costs

There are several inputs in a firm whose owner is he himself and their use he does himself. For these the firm has not to pay an outsider. But if the firm uses them for its own purpose then it has to sacrifice the income which it gets from them on rent. For example, when a firm uses its own building, then it

**Notes**

has not to pay rent to anyone . But on giving, this building on rent to another person the rent which it can get from that building, it has to sacrifice this loss. In economics, a firm's own resources opportunity cost is called implicit costs.

According to Leftwitch, “Implicit costs are costs of self-owned and self-employed resources.”

– Leftwitch

For a firm implicit costs are those monetary payments which the firm for better uses of its own resources can get by selling or giving on rent. Like explicit costs, implicit costs are also the sacrifices done by the firm.

But in contrast to explicit costs these are not paid to other people. The implicit cost is equal to that **Imputed Value** of self owner and self consuming products which can get by superior optional product. For an economist, the cost of a factor is equal to its price which a firm spends on the factor for not on its own but for another firm. For example, Ram is a sole proprietor of a book shop. The building is his own. He puts the cost in his industry and work alone. Means however he does not need to pay anything like wages or rent to run his business means there is no **Explicit Cost** with him. But he needs to bear **Implicit Costs** like wages, interest etc. He can earn ₹ 400 by renting his building for a shop to anyone. Thus by using his own building, he is scarifying for ₹ 400. Thus, he is scarifying the interest which he could get form his capital. If Ram is not running his shop, he could work on another shop and earn wages. But to run his firm, he is scarifying from this amount too. The Normal Profit is the minimum income which Ram needs to run his firm. **Normal Profit** is the implicit cost of Ram’s firm. This is also included in total cost. **Thus the implicit cost and actual cost are included in Total cost.**

**9.2 Costs in the Short Run**

Since short-term productivity costs close relationship, so a short-term productivity cost is related to each measurement. Which means like stable and variable resources, fixed and variable costs are exist. Similarly, the way on which total, average and aggregates of production are measured in the same total, average and aggregates of costs are measured. In short, cost and productivity are mutual.

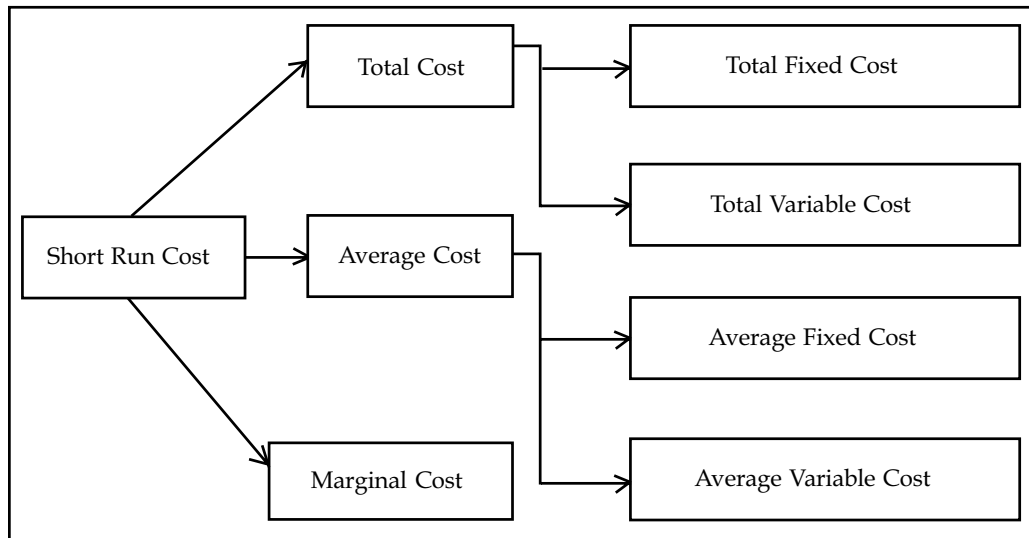

**Self Assessment**

Fill in the blanks:

1. Generally speaking the “cost” is the term used for ..... cost.
2. Opportunity cost is the cost of other outstanding ..... which is discarded.
3. Under the explicit costs, opportunity costs include the costs .....

### 9.3 Total Cost

To produce different levels of an object, the money which has to spend is called the total cost. In short term fixed and variable modes are divided into two categories, similarly, the firm's total production costs are divided into two categories. Total fixed costs and variable costs of fixed assets to total variable costs is the cost of resources. Thus, total cost is the sum of total fixed cost and variable cost.

$$TC = TFC + TVC$$

(Here, TC = Total Cost, TFC = Total Fix Costs, TVC = Total Variable Costs)

In the words of **Browning**, "Total cost (TC) is the sum of total fixed cost and total variable cost for each output level." The total cost required for the production of an object by means of the cost of all fixed and variable resources appear. The total cost is always increasing with output. The cause of this is that for increasing production always require more resources.

#### Total Fixed or Supplementary Costs

In short term, the cost of fixed assets is called total fixed costs. Fixed costs are the product of the units and the prices of fixed asset .

$$\text{Total Fixed Cost (TFC)} = \text{Units of Fixed Resource} \times \text{Price of Fixed Cost}$$

These costs do not change with the volume of production. If the output is zero, the cost will remain stable.

In the words of **Ferguson**, "Total fixed cost is the sum of the short run explicit fixed costs and the implicit costs incurred by an entrepreneur."

–Ferguson

**Some fixed costs do not change with the volume of production.** If a firm stops production for sometime even it has to pay the total fixed cost.

In a carpet rug factory more and more carpets can be made in a day. The manufacturing fixed cost of carpet is ₹ 100. In that factory even a single piece of carpet is not made in a day, fixed cost will remain ₹ 100. If on the second day six carpets are made then also fixed cost will remain ₹ 100. This is also called supplementary cost on indirect cost or overhead cost on Historical costs or unavoidable costs. In fixed cost following expenditures are included. – (1) Rent (2) Depreciation (3) Manager, salaries of administration (4) Interest on fixed capital (5) Lessons fees (6) general benefit and (7) depreciation expense insurance etc. Fixed costs can be explained by Table 1 and Fig. 9.2. It is known from table - 1. with changes in quantity of production even if the quantity of production becomes zero then cost will remain rupees 10. If the quantity of production increasing becomes rupees two or four or six even then fixed cost will remain rupees 10.

Output	Fixed Cost (in ₹)
0	10
1	10
2	10
3	10
4	10
5	10
6	10
7	10
8	10

Notes

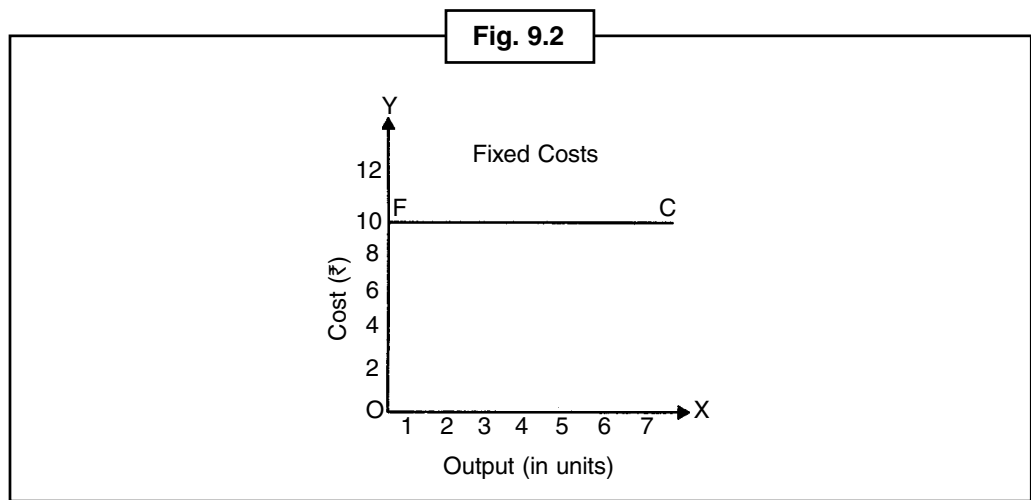

In Fig. 9.2 on OY axis the units of production costs and on OX axis units of output are given. FC line is bound to reveal the costs. This line is parallel to OX axis. From this it is clear that cost will remain fix even the output is low or high. This FC line is touching OY axis at point F. From this it is clear that output is zero even then bound cost will remain rupees ten.

**Total Variable Cost**

The variable cost is the cost which is applied in input and output factors of production.

According to Ferguson, "Total variable cost is the sum of amounts spent for each of the variable inputs used."

—Ferguson

**Self Assessment**

**Multiple choice questions:**

4. Financial cost is different from ..... cost.
 

(a) ledger Cost	(b) curve
(c) straight	(d) social
5. Social cost is different from ..... cost.
 

(a) ledger Cost	(b) social
(c) curve	(d) personal
6. The implicit cost of production is the ..... cost of ownership and self cost.
 

(a) factors	(b) social
(c) products	(d) money
7. The difference between social and personal cost is .....
 

(a) external cost	(b) implicit cost
(c) private cost	(d) rupee cost
8. The total fixed cost does not with quantity of production .....
 

(a) fixed	(b) variable
(c) changed	(d) unchanged

Variable cost is one which varies at the level of output. This cost changes if production changes. If production gets low then this cost decreases and vice versa. If the production is zero, this cost is also zero. These costs are also called Prime Costs, Direct Costs or Avoidable Cost. These expenditures are included in variable cost – (1) Expenditure on raw material, (2) Wage of direct labour, (3) Expenditure on electricity and (4) Expenditure on repairing.

The variable cost can be shown by Table 2 and Fig. 9.3.

Table 2: Variable Cost	
Output	Variable Cost (in ₹)
0	0
1	10
2	18
3	24
4	28
5	32
6	38
7	46
8	62

Table 2 shows that as the production increases, the variable cost also increases. When production was **zero** then this cost was also zero.

In contrast, when production is increased by 1, then the variable cost is ₹ 10. When production is increased and comes at 6, then the variable cost is ₹ 38.

From the above table it is clear that the variable cost of every factor of production does not find the similar changes. The increment in variable cost is low until the four units of production. There is equal increment in fourth and fifth units. After that, the variable cost of every unit is increasing. The main reason behind this is to imply the Law of Production.

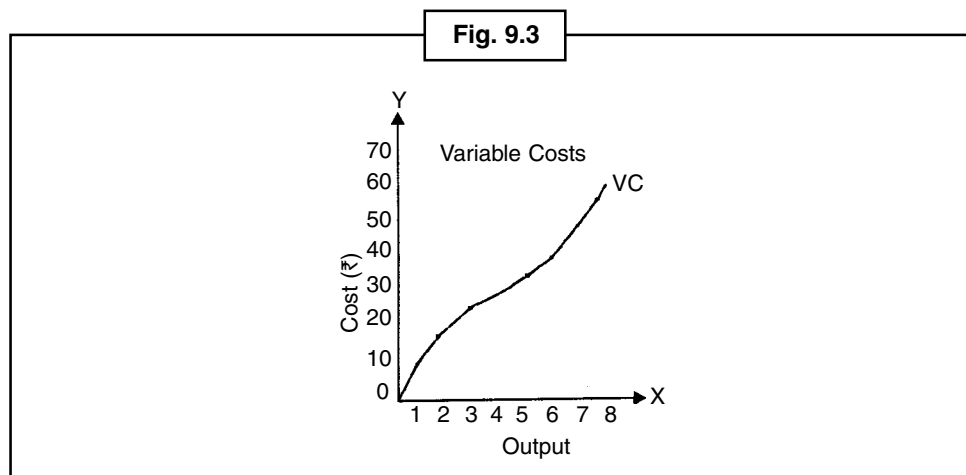

The variable cost can be represented by Fig. 9.3 too. In this figure the quantity of production is represented on axis OX and cost is on axis OY. VC is variable cost curve. This curve is like **inverse S**. This curve is going upwards. This proves that this is reflecting the variable factors of law. By this law, it is clear that in the early stage of production, as quantity of production increases, the variable cost also increases. This condition occurs till that point where the variable cost and the fixed cost mix. After this as the variable factors mix and use with fixed factors, the productivity of variable factors gets low and the average of variable cost increases.

**Notes**

When marginal cost gets low, then TVC increases in decreased rate. But when marginal cost is increased then the TVC increases in increased rate. (Note: Marginal cost indicates the rate of TVC; Increased MC means TVC is increasing in increased rate; Decreased MC means TVC is increasing in decreased rate).



*Did u know?* The implicit cost of production is self costs as well as the factor cost.

### 9.4 Relation Among Total Cost, Total Fixed Cost and Total Variable Cost

The total cost in various levels of production in short run is the addition of total fixed cost and total variable cost.

The relation among the total cost, total fixed cost and total variable cost is represented by Table 3 and Fig. 9.4.

Table 3: Total Cost			
Output	Fixed Cost	Variable Cost	Total Cost
0	10	0	10
1	10	10	20
2	10	18	28
3	10	24	34
4	10	28	38
5	10	33	42
6	10	38	48
7	10	46	56
8	10	62	72

In Table 3, the total cost can be assumed by the addition of fixed cost and variable cost. The total cost is increased as the production increases. When production is zero even then the total cost is ₹ 10. The variable cost is zero though. When production is increased by 6 units, then the variable cost is ₹ 48 (₹ 38 + ₹ 10). The total cost can be represented by Fig. 9.2 also. In Fig. 9.4, the quantity of production is on axis OX and the cost is on axis OY. FC is closed cost curve. VC is variable curve and TC is total cost curve. This curve represents the addition of FC and VC. TC curve starts from the original point of FC curve.

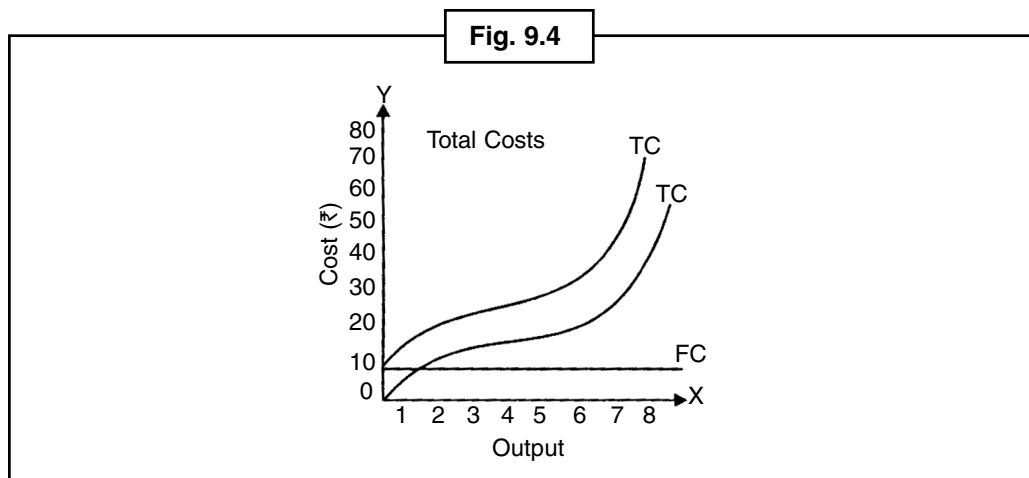

The production is 0 at point O but FC is ₹ 10. So the total cost is also ₹ 10. The difference between total and variable cost is equal to fixed cost. So there is equal difference between TC and VC curve. So both the curves means TC and VC curve are parallel to each other.

### Significance of Difference between the Fixed and Variable Costs

There is the significance of difference between the fixed and variable costs in short run.

**Production decision during Depression or decision regarding Shut Down:** The demand and the price get low in short run due to crisis. The firm needs to decide whether to open its production or close. If firm closes production even then it needs to bear the rent of building, the interest in fixed capital etc. So the firm gets loss even it shut down the production in short run. Thus if in crisis time, the product's price is as low as to equal to variable cost, the firm will resume their production. It would bear the loss of fixed cost. Firm will produce until it gets variable costs. But if the firm does not get variable cost, it will shut down its production.

## 9.5 Average Cost

The average cost is the cost of per unit of product. Average cost is total cost divided by output. It has three parts – (i) Average Fixed Cost (ii) Average Variable Cost (iii) Average Total Cost or Average Cost .

### (i) Average Fixed Cost

**Average fixed cost is the fixed cost per unit. Total fixed cost is divided by the quantity of output average fixed cost that is called the quotient. Means,**

$$AFC = \frac{FC}{Q}$$

(Here AFC = average fixed cost, FC = fixed cost, Q = quantity of output).

Since fixed cost remain constant, therefore, produce higher fixed cost per unit is lower.

From Table 4 and Fig. 9.5 we can explain average fixed cost.

Table 4: Average Fixed Cost		
Output (1)	Fixed Cost in ₹ (2)	Average Fixed Cost (3) = (2 ÷ 1)
1	10	10.0
2	10	5.0
3	10	3.3
4	10	2.5
5	10	2.0
6	10	1.7
7	10	1.4
8	10	1.2

From Table 4 it is clear that when one unit is produced the average fixed cost is ₹ 10. Opposite to it when 5 units are produced then the average fixed cost decreases to ₹ 2. The average fixed cost of production decreases with increase in production. Figure 9.5 AFC is the average fixed cost line. The line is sloping downward to the right. From the nature of average fixed cost falling downward it is clear that any where this curve will touch OX axis. But it is not possible because the point where AFC curve will touch OX axis in that place AFC should be zero. But

#### Average Fixed Cost Curve is a Rectangular Hyperbola.

*The reason behind this is the area drawn beneath a rectangular hyperbola is equal. And all areas represent a fixed cost which is fixed.*



**Notes**

AFC can never be zero because FC cannot be zero. It is proved that with increase in production average fixed cost decreases. Average fixed cost is a rectangular hyperbola because at every point total fixed cost is equal.

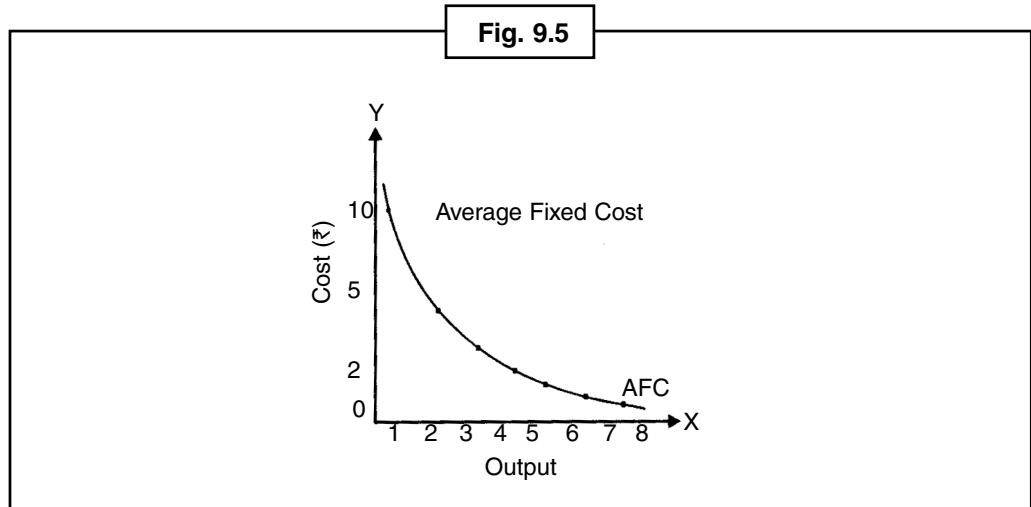

**(ii) Average Variable Cost**

Average variable cost is average cost per unit. Its estimation is done by dividing total variable cost with quantity of output. So, average variable cost is total variable cost divided by output means

$$AVC = \frac{TVC}{Q}$$

(Here AVC = average variable cost, TVC = total variable cost, Q = quantity of output). Average variable costs can be explained by Table 5 and Fig. 9.6.

<b>Table 5: Average Variable Cost</b>		
<i>Output (1)</i>	<i>Total Variable Cost in ₹(2)</i>	<i>Average Variable Cost (3) = (2 ÷ 1)</i>
1	10	10
2	18	9
3	24	8
4	28	7
5	32	6.4
6	38	6.3
7	46	6.6
8	62	7.8

From Table 5, it is clear that with increase in output the average variable cost of production reduced to sixth unit, but from seventh unit began to lift. The cause of this is that at the starting of production the increasing return rule is applied. For this average variable cost decreases. After a limit, decreasing return rule of production is applied. That is why cost increases.

Average cost can be clarified from Fig. 9.7. In Fig. 9.7, on OX axis output is presented and on OY axis cost is presented. AC curve shows the average cost. This curve looks like English alphabet 'U'. From this

it is clear that with increase in output initially average cost decreases. After a limit it increases. The cause of this is that initially when output increases then decreasing return rule is applied. After a limit when output increases then increasing return rule or average cost rule is applied. For this, this curve looks like increases up.

Notes

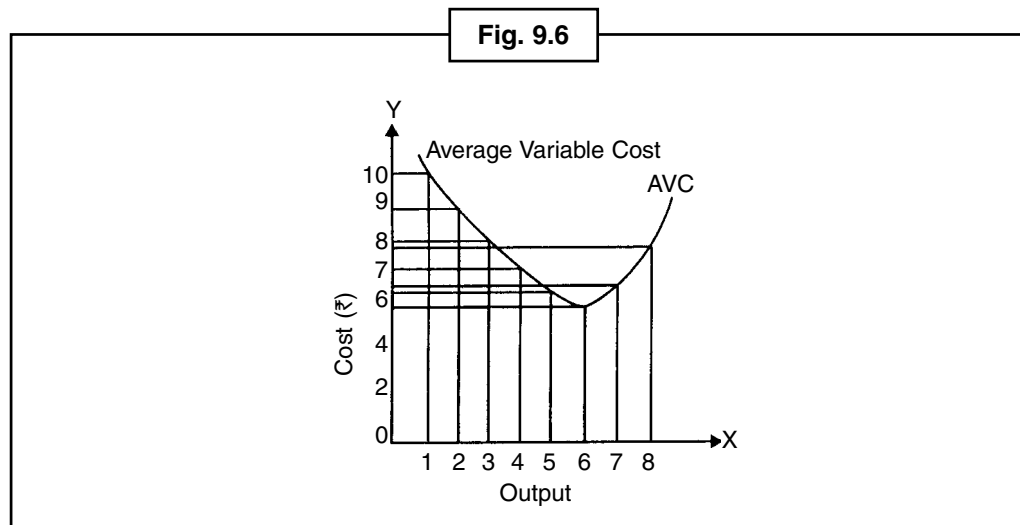

### (iii) Average Total Cost or Average Cost

Per unit cost of an object is called the average cost.

According to Ferguson, "The average cost is total cost divided by inputs."

We can define average fixed cost and average variable cost; average cost is defined as the sum. It means all the fixed and variable cost per unit is a measure of the average. It can be expressed as follows:

$$AC = \frac{TC}{Q} = AFC + AVC$$

(Here, AC = average cost, TC = total cost, Q = quantity of output, AFC = average fixed cost, AVC = average variable cost.)

Let an item of six units has a total cost of ₹ 180, The average cost per unit cost or  $180/6$  will be ₹ = 30.

Table 6 and the average cost can be interpreted with the aid of Fig. 9.7.

Table 6: Average Total Cost			
Output	Average Fixed Cost in ₹ (AFC)	Average Variable Cost in ₹ (AVC)	Total Cost AC = AVC + AFC
1	10	10	20
2	5	9	14
3	3.3	8	11.3
4	2.5	7.0	9.5
5	2.0	6.4	8.4
6	1.7	6.3	8
7	1.4	6.6	8
8	1.2	7.8	9

**Notes**

In Table 6, the average variable cost and average fixed cost is estimated by adding the average cost. Seventh unit is less than the average cost. Because the average fixed and average variable costs are also reduced. Seventh unit has the lowest average cost, average cost is increasing because the AVC is also increasing.

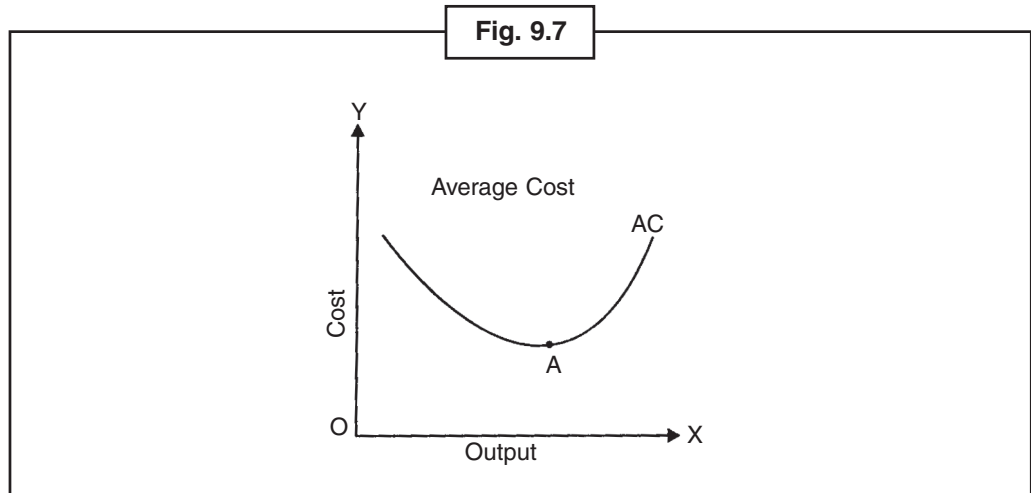

Average costs can be explained by Fig. 9.7. In Fig. 9.7 production is shown on OX axis whereas OY shows cost. AC curve is disclosing average cost. This curve is like the English alphabet U. It appears that the average cost of production is just beginning to grow. After a limit it starts increasing becomes increase. The cause of this is in the beginning, when output growth is increasing then increasing or decreasing of the cost of return rule applies. After a range increasing or decreasing the production yield is applies the law of increasing yield and take it up the curve.

### 9.6 Why is the Short Run Average Cost Curve 'U' Shaped?

Short-term average cost curve is U-shaped. The significance of this happened before the curve downward and falls. After it reaches the lowest point and then rises. U-shaped average cost curve can be interpreted to be the following three ways:

- (i) **Interaction of Average Fixed Cost and Average Variable Cost:** Average cost is the sum of average fixed cost and average variable cost. As the production increases average fixed cost decreases, the average variable cost is also reduced. So initially the average cost decreases to the point A of Fig. 9.7, the average cost curve is falling. As the average curve keeps on falling and becomes minimum at point A. Potential output in the form of the condition is thought to be fully utilized. Model output is also known as the volume of production. Increasing the volume of production beyond the average fixed cost curve is falling, but the average variable cost curve begins increasing as a result, the average cost curve and rise above it. **This is because the rate of increase of the AVC, AFC is more than the rate of decline.** As a result, the total effect of the increase in the average cost curve i.e., the AC comes in the form of rising to the top. Thus the average cost curve, average variable cost and average fixed cost falls down before being added to the lowest point after it reaches the next move is started.
- (ii) **Application of the Law of Variable Proportions:** A Committee with any other means of production in the short decreasing- increasing production, reducing the use

*U-shaped average cost curve means the proceeds to be applied. The subsequent fall in the average cost curve is due to increasing returns, The latter to remain stable due to stable return and the return is due to decreased subsequent to rise above.*

of resources is the growing proportion of the rule. Beginning with stable means of dynamic resources are used more efficiently. Consequently, the average cost goes down. Figure 9.7 is known as a point of diminishing returns or cost of production. This proves stable means of production is being optimally utilized. This situation persists to some extent on the production and post production of a range Laws may return identical or similar costs, this situation seems to be at point A. After point A full potential use of resources seems to be a constant change, to use their resources more and tied proportion of resources is reduced. This in turn decreases the efficiency of the instrument variable. Increasing rate decreases in the production and decreasing production costs, increasing returns or the applicable law. Rising costs due to the rules applicable after point A, the average cost rises.

## 9.7 Marginal Cost

To produce an additional unit of a commodity in which the difference between the total cost is called the marginal cost. This can be explained by the following formula. Let the total cost be ₹ 135 of 5 objects and for 6 objects, the total cost be ₹ 180. Therefore, the marginal cost of the sixth object can be calculated.

$$\text{Marginal Cost} = ₹ 180 - ₹ 135 = ₹ 45$$

Therefore, the marginal cost of the sixth unit will be ₹ 45.

According to **Mc Connell**, “Marginal cost may be defined as the additional cost of producing one more unit of output”

– Mc Connell

According to **Ferguson**, “Marginal cost is the addition to total cost due to the addition of one unit of output.”

– Ferguson

Change in cost divided by the change in production or  $n$  by  $n - 1$  of the total cost of the unit down the total cost of the marginal unit cost can be determined. This can be explained by the following formula-

$$MC = \frac{\Delta TC}{\Delta Q} = TC_n - TC_{n-1}$$

(Here MC = marginal cost,  $TC_n = n$  the total cost amount,  $TC_{n-1} = n-1$  the total cost amount,  $\Delta TC$  = total cost changes and  $\Delta Q$  = change in volume of production.)

This should take care of the fixed cost (FC) does not change with the change in output in the  $\frac{\Delta FC}{\Delta Q}$  is always equal to zero. The firm's marginal cost does not affect the fixed costs. Marginal impact on the cost of the total variable cost (VC). An estimate of the total variable cost of ( $\Delta VC$ ) producing the change in the amount divided by the ( $\Delta Q$ ) change can be detected.

$$MC = \frac{\Delta TC}{\Delta Q} = \frac{\Delta FC}{\Delta Q} + \frac{\Delta VC}{\Delta Q} = \frac{\Delta VC}{\Delta Q}, \therefore \Delta FC / \Delta Q = 0$$

The concept of marginal cost can be understood with the help of Table 7 and Fig. 9.8:

Units of Output	Total Cost	Marginal Cost
1	20	20 - 0 = 20
2	28	28 - 20 = 8
3	34	34 - 28 = 6
4	38	38 - 34 = 4
5	43	42 - 38 = 4
6	48	48 - 42 = 6
7	56	56 - 48 = 8
8	72	72 - 56 = 16

$$\Delta FC = 0$$

The reason, according to the definition of the fixed cost does not change.

Marginal cost is the additional cost of the object is used to produce one more unit. Keep in mind the additional cost may be the only variable cost.

**Notes**

Table 7 suggests that to produce the first unit there is an increase of ₹ 20 in the total costs ₹ 20 will therefore be marginal cost of the first unit. Marginal cost of the second unit will be (₹ 28 - ₹ 20 = ₹ 8). Hence, the marginal cost of the third unit will be (₹ 34 - ₹ 28) = ₹ 6. This is evident from the table before the increment in production marginal cost initially decreases. Then it starts to grow. Marginal costs can be explained by Fig. 9.8. Axis OX shows production (output) and on OY axis in the figure the marginal cost of production has been revealed. MC curve is the marginal cost curve. This is U shaped curve. This is accomplished that early marginal cost of production is reducing and increasing thereafter.

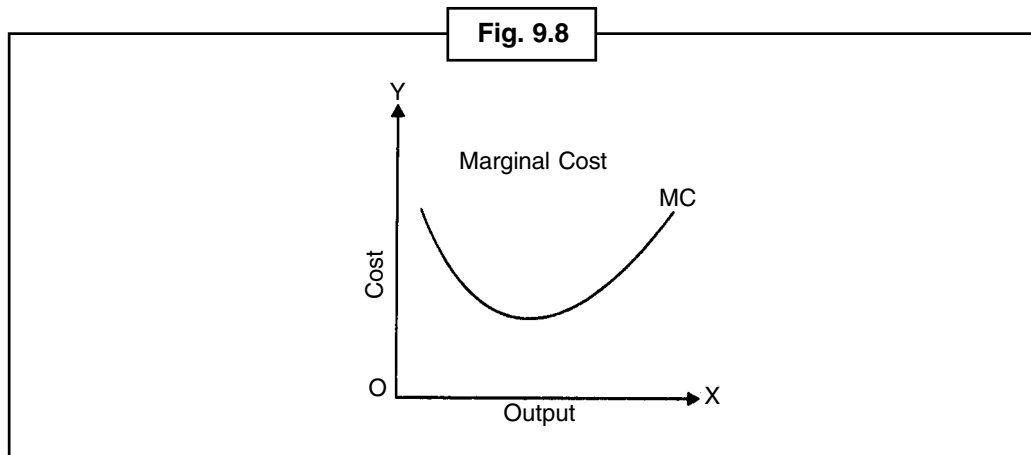

**9.8 Why is MC Curve 'U' Shaped?**

Marginal cost, total cost or variable cost of producing one unit more or less reflects the change. Initially the output when the total cost and the variable cost are increased by decreasing rate. This is because increasing returns at the beginning of the production rule applies. The firm provides a variety of savings. The effect of this is, the cost of each additional unit is less than the previous unit. The MC falls so early. After a certain extent, the growth in the total cost and variable cost is minimal if MC is also minimal. Thereafter, increasing the total cost and variable cost rate increases. This is because the output of the applicable law of decreasing returns. The firm has a variety of impairments. The cost of each additional unit exceeds the cost of the last unit is also increasing the MC. MC falls in the beginning, after arriving at the lowest point increases.

Notes
Marginal cost can be defined as extra cost incurred for producing an extra unit of object.

**9.9 Relation between Average Cost and Marginal Cost**

Economic analysis, especially product pricing and relation between average cost and marginal cost of product are important concepts to be understood, and marginal cost pricing is essential. Table 8 explains this.

Table 8: Average Cost and Marginal Cost of Product

Production	TC	FC	VC	AFC	AVC	AC	MC
0	10	10	0	$\infty$	0	$\infty$	$\infty$
1	20	10	10	10	10	20	10
2	28	10	18	5	9	14	8
3	34	10	24	3.3	8	11.3	6
4	38	10	28	2.5	7	9.5	4
5	42	10	32	2.0	6.4	8.4	4
6	48	10	38	1.7	6.3	8	6
7	56	10	46	1.4	6.6	8	8
8	72	10	62	1.2	7.8	9	16

1. **When AC Falls, MC is less than AC:** If the AC curve falls below the (MC) curve will be below it because the average cost (AC), average fixed cost (AFC) and average variable cost (AVC) is the sum of the marginal costs only variable cost (VC) involves changes in the Fig. 9.9, BF makes it clear that the MC curve to reduce the cost of the variable rate both variable and fixed costs are greater than the sum of the rate of reduction. Figure 9.9 is also shows that after the point F, the additional variable costs or marginal cost increase is initiated; the average of the sum of the fixed and variable costs are falling through E, AC curve point. Both AC and MC at point E are equal.

Fig. 9.9

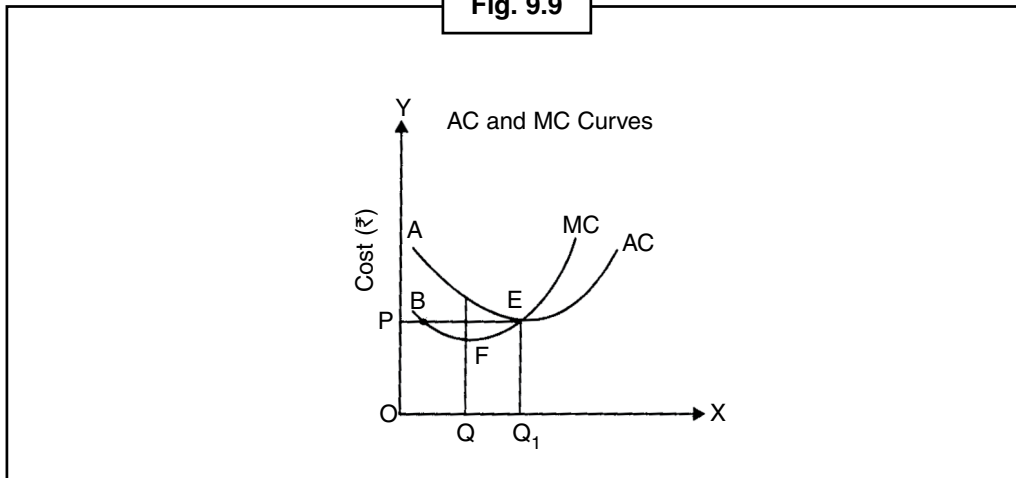

#### Does MC Rise When AC is Decreasing?

Generally, it is said, when AC is low, MC is low too. But this statement for each level of production is not right. This is possible when AC is decreasing, then AC is increasing. It can be determined by Fig 9.9 that the output OQ and MC are both low. But after that point (after F) has grown in the MC, AC continues to fall. This is because the minimum point of the MC F, AC, is the lowest point since before E, AC falls more rapidly than MC. After point F, additional variable cost or marginal increase in costs, but the combined average variable cost and fixed cost falls to AC curve E is the point. One point E at the AC and MC are equal to each other.

Efficiency of AC on expanding the MC for the latter may be declining while the average price is less than marginal cost.

Notes

2. **When AC rises, MC is greater than AC:** If the average cost increases marginal cost also increases, but the marginal cost rises faster than the average cost. This is because of the Law of Diminishing Returns. Average Cost (AC) in the Fixed Cost (FC) reduces the rate of increase in the fraction. Marginal and average cost curves up the slope and then the MC curve is above the curve AC.
3. **MC Cuts AC at its Lowest Point:** The lowest average cost will be equal to the marginal cost. In other words, the marginal cost curve is U-shaped average cost curve at its lowest point. Table 8 is determined by the lowest average cost that is the seventh unit is ₹ 8. Seventh unit's marginal cost (MC) is the 8 rupees. Figure 9.9 is determined by the marginal cost curve (MC), Average Cost (AC) curve at the minimum point E is cut. This should take care of the marginal cost curve the average cost of the lowest point of the average cost has come before. Table 8 is determined by the marginal cost (MC) is the lowest point on the fifth unit, while the average cost at the lowest point is the seventh unit. The question is why is it produced? There is no economic reason. Marginal and average curve is characterized primarily mathematical.

When AC is stable then  $AC = MC$ . In contrast, when the AC is falling  $AC > MC$ , but when the AC is increasing  $MC > AC$ .

### 9.10 Relationship of Different Cost Curves in the Short Period

The cost of short-term fixed costs (FC), Variable Costs (VC), the average fixed cost (AFC), the Average Variable Costs (AVC), average cost (AC) and marginal cost (MC) with a study of Fig. 9.10 can be done with the help of.

1. **Average Fixed Cost Curve:** It is tilted up and down. This is known as the AFC decreases as output increases. Initially drops quickly. Thereafter it slows down the rate of reduction.
2. **AVC (Average Decrease – Increase the Cost Curve):** It is falling to point A. The point A is the lowest point. AVC curve at this point is equal to MC. After that point A is pointing upwards. This is also U shaped, but also like the AC curve is much deeper.

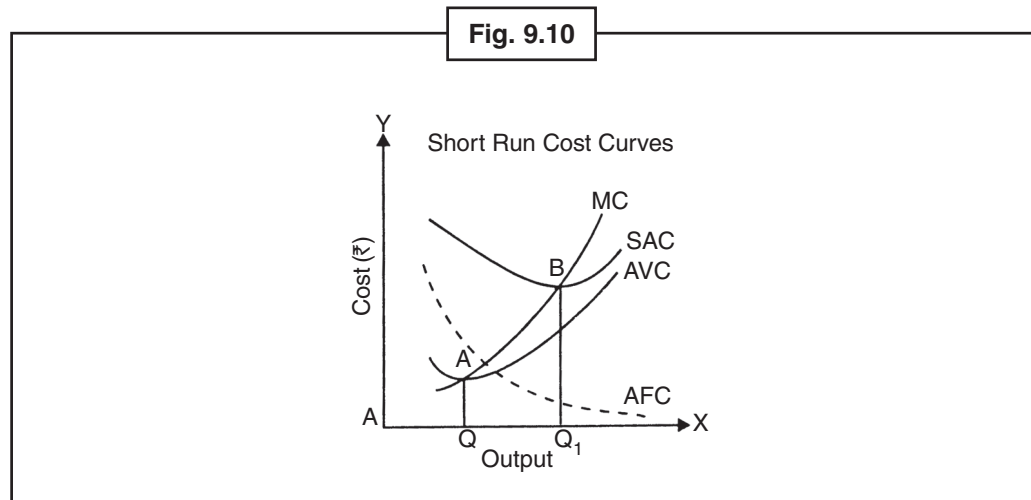

3. **SAC (Short-Term Average Cost Curve):** It also has a U shape. The first fall, reaches a minimum point B, and then gradually increases, the minimum AC arrives at B, then the MC (SAC) equals it. Average variable cost curve (AVC), the lowest point 'A', the average cost curve (AC) to the lowest point 'B', comes before. It is important to note that the difference between average cost and average cost increases but gradually decreases. This is because the average fixed cost is equal to the fixed cost. As AFC decreases, the difference becomes less too.

*MC curve, SAC curve and the AVC curve intersect at minimum point in Fig. 9.10.*

4. **MC (Short-term marginal cost curve):** The marginal cost curve is also U-shaped. This means, it first decreases, reaches minimum at point A, and then increases upward. This leads to decreasing average cost curve (AVC) curve, and the average cost (AC) curve is crossed at their lowest point. When AVC, and AC are falling, the MC curve is at their bottom, and when they increase the MC curve is above them.

## 9.11 Relationship between Cost Curves and Productivity Curves

Cost curve and the productivity curve are in opposite relationship. Curve with respect to cost and productivity can be explained with the help of Fig. 9.11.

In figure 9.11 OX axis represents productivity. In figure 9.11 (A) OY axis shows costs whereas OY represents production. Fig. 9.11 (A) of the MP curve is marginal productivity curve, and the average productivity curve is AP curve. In Fig. 9.11 (B) MC curve is the marginal cost curve and AC curve is the average cost curve.

*You must understand the cost and productivity are opposite to each other. The AC and MC respectively: AP and MP is the opposite.*

From Figs. 9.11 (A) and 9.11 (B) the following points become clear-

- (1) While increasing the MC, MP is falling, but when MP is falling, MC is increasing. When MP is maximum (at point A), the MC is minimal (at point C).
- (2) Increasing the AP, AC is falling. But when the AC is increasing AP is falling. When the AP is maximum (point B), the AC is minimal (at point D).
- (3) MP curve cuts AP curve at its highest point 'B' and shrinks faster than AP. MC curve cuts AC curve at its lowest point (D) and grows faster than AC.

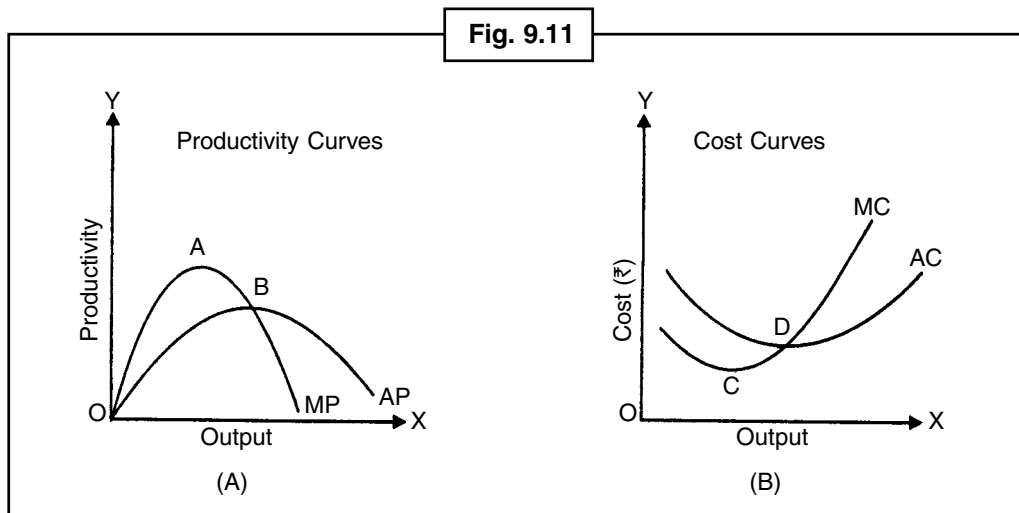

## 9.12 Costs in Long Run

Long is the period of time in which the instrument is subject to change. Firm has enough time to use all the tools needed to produce at minimum cost. In other words, longer the period of another aspect of the firm is planning to produce at minimum cost. Firms can make long-term plans for the future, and various methods of short-term can be chosen from, the production method which they adopt in the long run. In the long-term in a way, all methods are available, of which the firm may choose. In



**Notes**

short, each firm operates in the short-term production, but it is made for long-term production related schemes. Therefore, a firm’s production plans related to knowledge is necessary to study the long-term costs. Short and long-term cost of the depends on three things – (1) **long-term total cost (LTC)** (2) **long-term average cost (LAC)** (3) **long-term marginal cost (LMC)**.

**9.13 Long Run Total Cost – LTC**

In short, we can distinguish three types in the total cost, total fixed cost (TFC), total variable cost (TVC) and short-term total cost (STC) of the same type but in the long run total cost (LTC). **Long-term total cost of the minimum cost at which each level can be produced.**

According to Leibhafasky, “The long run total cost of production (LTC) is the least possible cost of producing any given level of output when all inputs are variable.”

– Leibhafasky

A certain amount of objects in the long run a firm can produce at minimum cost. This is because the firm has sufficient time in which it (i) can choose the ideal size plant (ii) Least Cost Factor Production.

It implies that short-term total cost will be less than or equal to the total cost. But the long-term costs never cost more than short-term. This fact can be explained by the following formula–

$$LTC \leq STC.$$

It will read as–Long Term Total Cost (LTC) will either be less than (<) or equal to (=) short term total cost (STC).

**Essential Overview**

*Production costs for each level of a point on the curve which reflects the short-term cost minimization. Long-term cost curve point is the path of all such points. Long-term cost curve is the envelope of the short-term cost curve.*

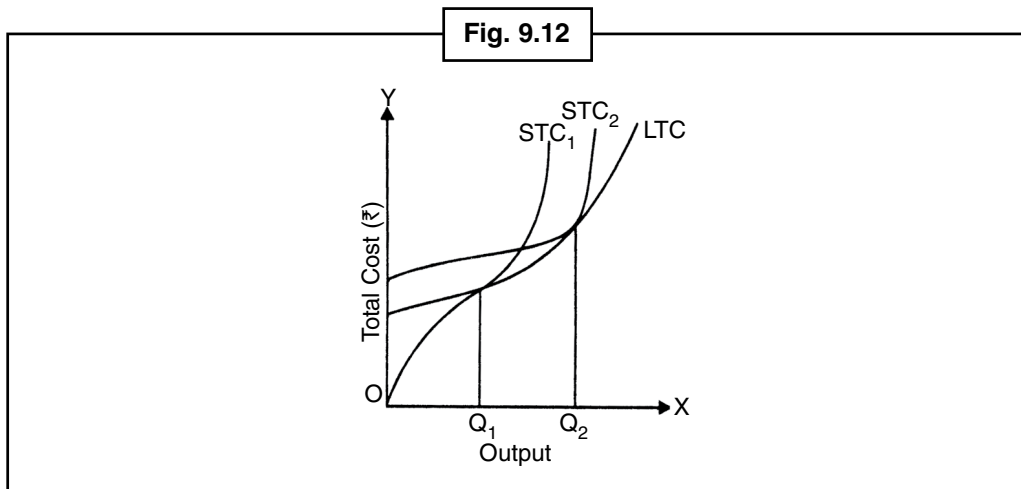

Long-term total cost curve at the minimum cost of production reflects various quantities. Therefore, it is the curve at a point short of the total cost to the touch line. This can be explained by Fig. 9.12. In Fig. 9.12 STC<sub>1</sub> and STC<sub>2</sub> in two different sizes of plants is a short-term total cost curve. Long-term total cost (LTC) minimum points and the curve consisting of various short-term cost curve is earmarked. Long-term cost is the minimum cost of production of a certain quantity of plants are all available to choose from. The total cost of long-term total cost curve is **tangent** to the curve that is why, **the curve LTC, envelopes curve STC.**

In Fig. 9.13, long-term total cost curve (LTC) is shown. This curve is in the shape of inverted 'S'. The following are the main features of the curve:

- (i) In Fig. 9.13, the total long-term cost curve starts from the origin point O, while the short-term cost curve of Fig. 9.12 is initiated from any point of the axis OY. The significance of this is due to variable costs in the long-term, the production volume is zero, and then the total cost is zero, while the short-term costs are never zero.

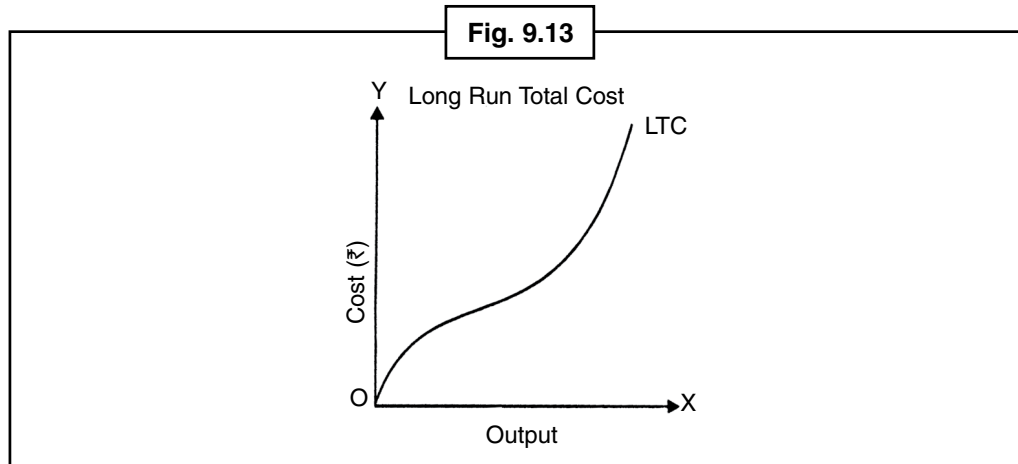

- (ii) Long-term total cost curve slope is positive. This means a large amount of the production costs are high.
- (iii) LTC curve at first decreases then increases at the same rate and the rate is increasing.

### Self Assessment

State whether the following statements are True/False:

9. The total cost divided by the amount of production gives average cost.
10. Average fixed cost curve is a Rectangular Hyperbola.
11. In production, the increase in the total cost which occurs due increment of one unit in production is known as Average Cost.
12. Long-term total cost is that minimum cost at which each level of production can take place.

### 9.14 Long Run Average Cost Curve or Envelope Curve

Long-term average cost, in the long run to generate various quantities of a commodity is the lowest possible cost per unit. In the words of Mansfield, "The long-run average cost curve is that curve which shows the minimum cost per unit of producing each output level, corresponding to different scales of productivity."

It is estimated when long-term total cost is divided by the quantity of production. The minimum average cost is received at that time, when all resources are dynamic and can be built to any size of the plant.

In the long run, each firm can use different sized plant. This fixed amount of production is better suited to a particular type of plant. The average cost of production with the help of the plant is minimal. Changes in production with demand - will change with the size of the plant. **Each plant has a short-term average cost curve (SAC). With it we can predict long-term average cost curve (LAC).**

**Notes**

Suppose a firm can use two types of plants. Its short-term cost curve is a **small** plant  $SAC_1$ . There is a **big** plant, its short-term cost is  $SAC_2$ . Of these two the firm is planning to invest in the most profitable plant. On various quantities of production both short-term cost curves can be determined with the aid of various quantities of output produced by the plant from which the average cost will be minimal.

In Fig. 9.14 Two types of plants appear to have been short-term average cost curves. Small plant's average cost curve is  $SAC_1$  while large plant's average cost curve is  $SAC_2$ . If the firm wants to produce quantities of OM it will select the smaller plant. The plant produces the lowest average unit costs with the help of OM on BM, as known from  $SAC_1$ . By contrast, OM unit to produce large plant, the average cost will rise to AM. But if the firm is to produce ON the unit will use the larger plant. Minimum average cost of production of the plant by the ON unit can be used by the CN, ON by the plant to produce smaller amounts DN will increase the average cost. If we take the value of the firm's plant has lots of different sizes Each level of the minimum cost of the plant to reveal the long-term average cost curve (LAC) will be called. Therefore, The production will be done by both small plant ( $SAC_1$ ) and large plant ( $SAC_2$ ) on the minimum average cost OM and ON respectively.

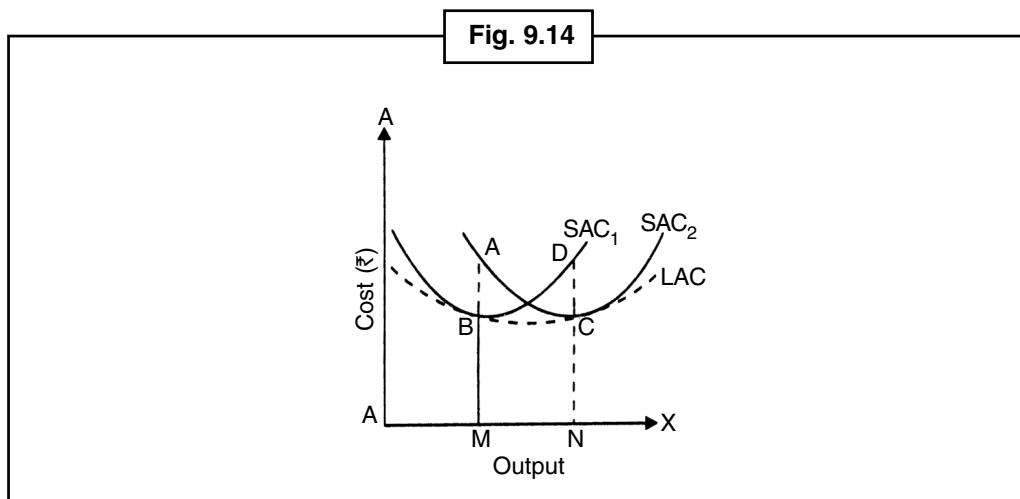

**You Must Understand this**

*The position of minimum input cost of short-term and long-term is not always same. This is because in the position of the minimum term at least one stage of production instrument remains where as this is not necessary in the long run. So the minimum output ratio can be maintained at all levels of production, but in short it is possible only at the production stage. Produce minimal short-term situation is similar to the level at which only the long-term expansion path is located. Therefore, the short-term cost of long-term cost curve is tangent to the curve at the same point.*

In Fig. 9.15, long-term average cost (LAC) is shown. Long-term average cost curve, the average cost of each short course is tangent to the curve at some point. The long-term average cost touch point short of the minimum point M to the left of the parts is below average cost. This is because the minimum point M to the long-term average cost (LAC) curve has a negative slope. The short-term average cost (SAC) will have a negative slope of the curve, because the touch point on the two parts of the curve will be going up. After point M, the long-term average cost curve is rising up. Point M in the long term and short term minimum average cost is a minimum average cost-equal to each other.

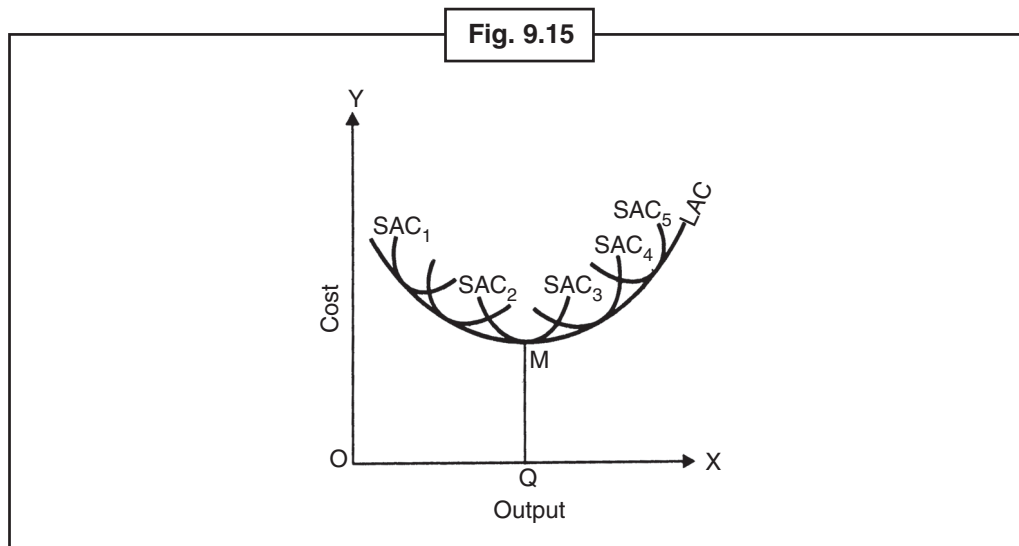

Therefore, it should be noted that, as stated by Holland, "The lowest point on each SAC curve, however, may not be the point of tangency with the LAC Curve. The lowest point on an SAC curve is tangent to the LAC curve only at the lowest point of the LAC curve." – Holland

Therefore, at the M point short of the ideal plant is used.

### Different Names

Long-term average cost curve is called by the following names–

1. **Envelope Curve:** This curve is called the envelope curve because it is able to cover all the short-term average cost lines. This means that the average cost in the long-term cannot exceed the average cost. Full Potential use of resources in the long run may be inseparable. The long-term average cost curve will encompass SAC curve. It will not cut these curves for going up.
2. **Planning Curve:** Average cost curve is also known as long-term planning curve. With the help of this curve firm can plan, for which plants used to produce various quantities that can be produced at minimum cost. In the words of Koutsoyiannis, "The long-run average cost curve is a planning curve, in the sense that it is a guide to the entrepreneur in his decision to plan the future expansion of his output."

### Why is LAC Curve U-Shaped?

Long-term cost curve is much like the English alphabet the 'U'. This implies that when a firm is scheduled to begin production LAC is falling from the top downward. At this stage of LAC decreases in production volumes grow. LAC remains **constant** thereafter. LAC after a certain amount of production would start to move. Average long-term cost due to economies and diseconomies of the scale of production is also U-shaped.

*Due to the increasing returns to scale in the long run cost curve is falling, remains constant due to the constant returns to scale and decreasing returns to scale is upward.*

1. **Economies of Scale:** Economies of scale are received by the downfall of LAC curve of a firm which results in the increment in the production.
  - (i) **Division and Specialisation of Labour:** According to Leftwitch, "A large number of plant specialization workers who work reasonably to have more opportunities." Work due to large

**Notes**

scale production of can be divided into smaller parts. Workers in each part of the work to be individualized. Workers acquire skills in that particular job, which is an increase in efficiency. Further specialization in a particular job saves time and capital. Division of labour has opened more opportunities for new developments. Consequently, the production cost per unit decreases.

- (ii) **Technical Economies:** Long-term increase in the scale of production is achieved as a result of a variety of technical avoid using automatic machines. Production costs can be reduced by advanced technology. So technically the average cost saving decreases.
- (iii) **Economies of Indivisibility:** According to **J.S. Bain** as a result of the indivisibility of the means of production to increase the average cost goes down. Several modes of production is required to use a certain amount, whether the output is low or high. For example, a production manager of a large firm can use it to its full potential. However, the **Production Manager** of a small firm cannot use the efficiency of the tenth part. Therefore, as the production volume increases unshared resources are used to their full efficiency and average cost decreases.

2. **Diseconomies of Scale:** Long-term average cost rose to the top of the main causes of the increase in production is due to the scale of the losses. And to coordinate the efficient management of a firm's efficiency has its own limitations. These limits are called scale losses. As the scale of production in a firm is contributed to a growth, division and specialization of tasks through the manager become more efficient. But after a limit increases the difficulties associated with managing the firm. The managers' business daily tasks gradually move away. This in turn decreases the efficiency of production and operation of various departments. The responsibility is to pass judgment on others. The expense for paper work, travel expenses, telephone bills increase. Occasionally coordination in various decision-making does not have plans to employees. As a result, production decreases and average costs increase.

### 9.15 Long Run Marginal Cost

The difference which comes in the total cost in the long-term in producing one object less or more is termed as long-term marginal cost.

In the words of **Ferguson**, "Long-run marginal cost is the addition to total cost attributable to an additional unit of output when all inputs are operationally adjusted."

—Ferguson

Long-term marginal cost curve is explained by Fig. 9.16. LMC is the long-term marginal cost curve. It first falls to become minimum and then rises.

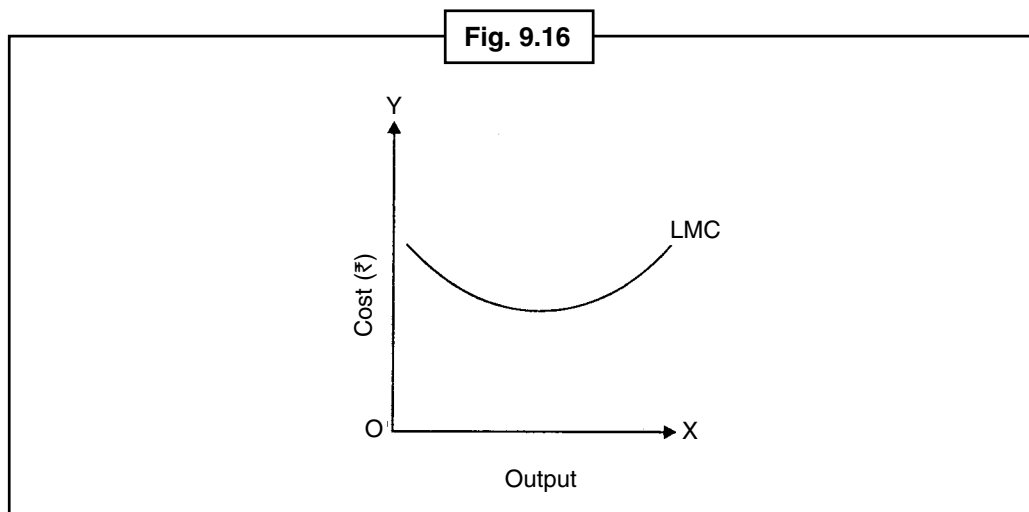

- (i) **Relation between Long Run and Short Run Marginal Cost:** The marginal cost curve determines a short, decreasing - increasing changes in the volume of an object to produce a more or less consequent impact on total cost. In contrast, it is determined by long-term cost curve, changes in the modes of production of a commodity, to a greater or lesser amount, consequent impact on the total cost.

In the long run we all know that all instruments are subject to change. Short-term marginal cost curve is determined by the marginal cost curve, but it does not envelopes them. Long-term marginal cost of production and short-term marginal cost (SMC) at that level (LMC), must be equal. SMC regarding the long-term average real cost curve (LAC) is a **tangent**.

When a firm develops an appropriate scale of the plant for the production of the object then, short-term and long-term marginal costs become equal to cost curve. As it is clear from Fig. 9.17 on the optimal product OQ,  $SMC = LMC$ . OQ output at the optimum level will be lower, then the SMC and LMC will be more. In contrast if the output is more than level OQ then SMC will be more and LMC in comparison to SMC will be less. LMC in comparison to SMC will be more flatter.

- (ii) **Relation between LMC and LAC:** LMC, and LAC relationship is evident from Fig. 9.17. The figure suggests that in long-term LMC and LAC hold the same relation as in short-term. When the LAC drops, LMC is less. LAC at the minimum point P is equal to LMC. The figure concludes that LMC curve in comparison with LAC curve falls down with a greater speed and even goes up with a greater speed. Optimum production point P,  $SAC = SMC = LAC = LMC$ .

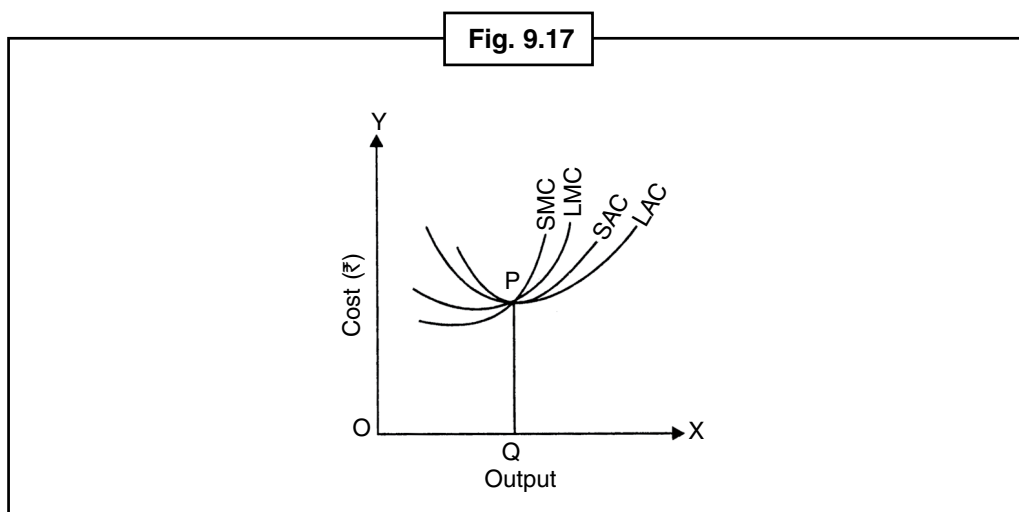

## 9.16 Modern Theory of Cost Curves

The modern theory of cost curves is rendered by the economists like **Stigler, Andrews, Sargent Florence, Friedman** etc. As per **Traditional Theory of Cost Curve**, the cost curves are **U-shaped**, means with the increase in production, the cost of production will decrease.

According to the modern theory of the long-term costs are mainly two types:

1. **Production Cost** and 2. **Managerial Cost:** As a result of the continuous increase in production, **production cost** decreases. In contrast, on a large scale production, managerial costs might increase. But the reduction in production cost is higher than the increase in managerial costs. With the increase in production in the long term - long-term average cost curve decreases. In the long run, each firm uses different sized plants. A certain production volume is appropriate for a particular type of plant. Each

**Notes**

plant has a short average curve. With its help we can estimate the LAC. Suppose a firm can use four types of plant size. The short-term cost curve is  $SAC_1$ ,  $SAC_2$ ,  $SAC_3$  and  $SAC_4$ . According to the modern theory of the cost curve, it appears that in long-term cultivation, a firm normally produces two third of the plant's efficiency. Efficiency cannot use the total output. From each plant's production capability related to SAC, LAC can be estimated. Figure 9.18 depicts the long-term LAC. Production capabilities' related output points of various short-term cost curves like  $SAC_1$ ,  $SAC_2$ ,  $SAC_3$ ,  $SAC_4$  give long-term average cost curve.

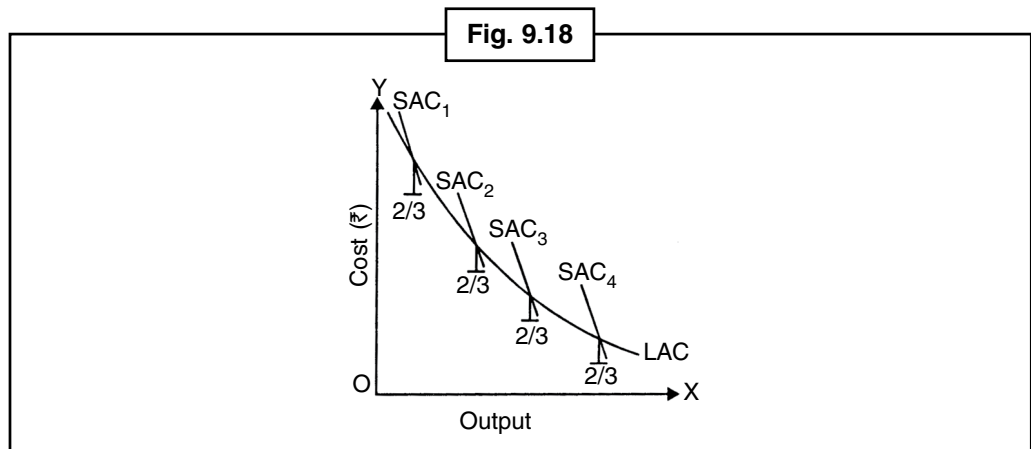
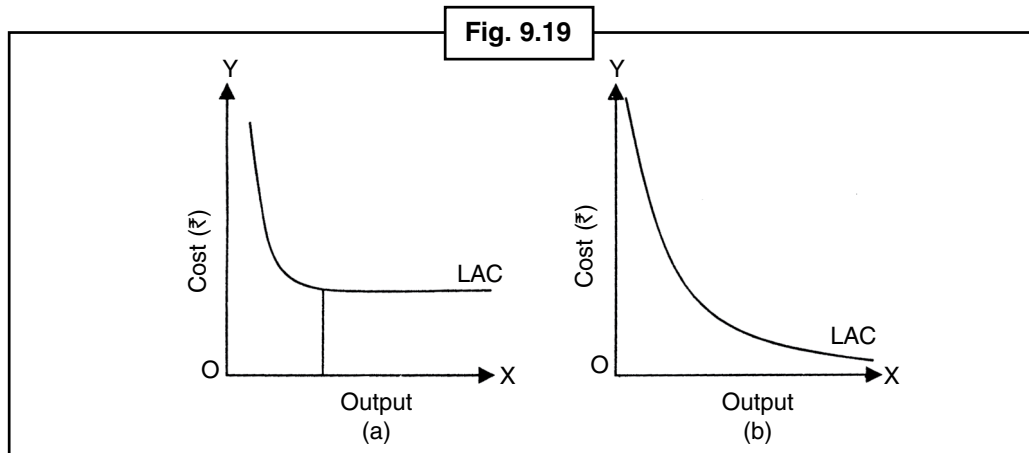

Figure 9.18 is determined by two main features of the long-term average cost curve-

- (1) No long-term average cost curve is U-shaped.
- (2) Long-term average cost curve is the envelope curve. The short-term cost curve intersects the cover in place.



According to modern theories LAC as shown in Fig. 9.19 (a), and (b), is either L-shaped or an inverted J-shaped.

1. **L-Shaped LAC:** Figure 9.19 (a) shows L-shaped LAC. It is L shaped because in long-term, there is a minimum scale for production, in which all links of savings are achieved. As a result, the cost of production after minimal ideal level is stable.
2. **Inverted J-Shaped LAC Curve:** Figure 9.19 (b) shows the reverse J-shaped the long-term average

cost curve. Long-term average cost curve is inverted J-shaped, because with the increase in the production cost of production decreases.

According to the modern theory, the cost relating to the data available, it certainly cannot be based on the long-term average cost curve is L-shaped or inverted J-shaped. But it can certainly be said that LAC, is not U shaped. It is U-shaped when it will be in a position to produce high-scale production may suffer losses. But in real life scale to production scale of losses is not high.

### 9.17 Long Run Marginal Cost Curves

According to the modern theory of the long-term marginal cost curve LAC relative size is the size of the type. LMC curve and the LAC curve relationship is shown by Fig. 9.20.

- (i) Figure 9.20 (a) shows that the LAC curve is L-shaped. The LMC is also stable and always LAC curve is below the curve. But the LAC curve is stable LMC curve is stable and coincides with LAC curve.
- (ii) Figure 9.20 (b) shows if LAC is in inverted J-shape when LAC curve is falling downwards, LMC is also falling downwards and the LAC, LMC curve while falling down is under the fallen part of LAC.

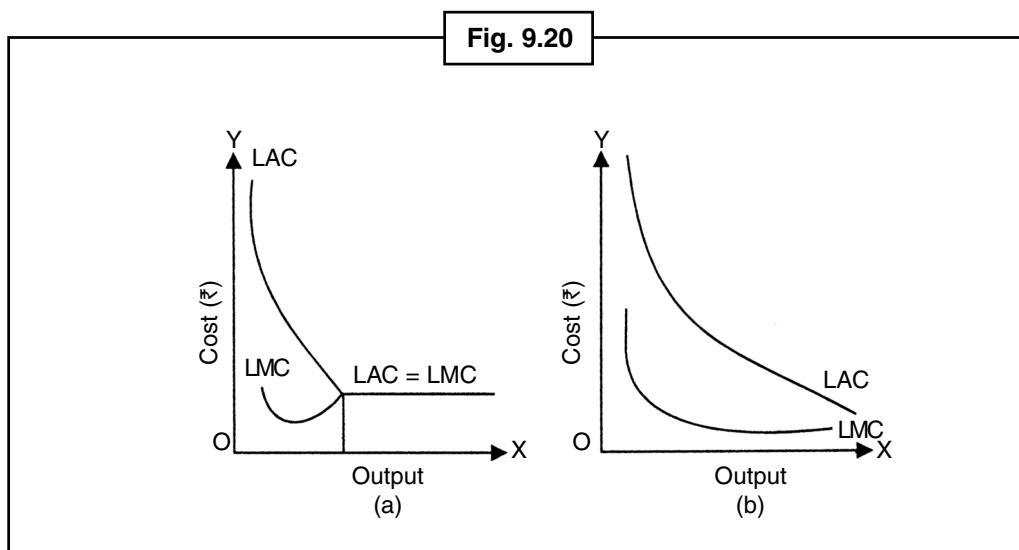

In Short, according to the modern theory of cost curve LAC curve often: L-shaped whereas according to the conventional theory it is U-shaped. Modern theory is more realistic than the conventional theory.



**Task** Express your views on the long-term marginal costs.

### 9.18 Technical Change: The Very Long Run

In short-term, a firm usually has labour as a variable. Whereas capital, plant and other means, such as furniture, production technology and remain stable. Thus, using greater amounts of labour



**Notes**

productivity can be improved as long as each additional unit of labour to produce  $MP_L$  as the **positive**. Placing additional labour costs or expenses are removed by generating an output that is mainly that by producing more spending is completed.

In the long run, all the means of production are variable, so firm the means to take all of them and can use different combinations. This combination is called a minimum cost. It is therefore made for all modes of production cost per unit is equal to marginal product, that is:

$$\frac{MP_L}{P_L} = \frac{MP_K}{P_K}$$

Over the long term, changes in self-production function, i.e, production technology can be used to change the way and therefore cost more to produce the same amount of output curve changes and slides downward. In other words, technological change is a change or newly created, with the cost of a given product, the available means of production can be reduced by using more efficiently.

The cost of production can be reduced by using the new scientific and modern innovation. **Schumpeter**, is an **exponent** of a monopolistic competition, because it inspires firms for innovations. Therefore, in long-term because of economic signals, great technological changes occur.

Technical innovation is the result of ever changing economic signals; a given change in market conditions as a result of these firms is to describe the dynamic response. Resources as a result of changes in the cost of replacement tools encourage firms to innovate.

For example, increasing costs of labour in the production of capital intensive firms / methods have begun to explore techniques (Increase in the value of labour, trade union and the government's wage policy due to legal requirements). Transport, communications, **manufacturing** and labour in the global nature of the place had become committed capital loss.

Over the long-term, technological innovation are not limited to a single country, but usually spread to all parts of the world. Suppose country 'A' using labour and capital has been able to produce cloth. In the short term there is an increase in the price of labour, because it cannot do Substitution of capital for labour in return. But the increasing cost of labour will not be in the interest of the country, it would lose its **competitiveness** in the world market. Such a loss inspires innovation, in order to gain market share. Over the long-term to reduce production costs, firms may engage in research and development. If they will be successful in developing such processes by which, as compared to other countries, they will bring their production costs down. The motivation is purely to change **endogenous** and these are not available on competitive countries, which is not affected by the increase in labour costs.

Therefore, changes in the price of any change in the production of economic signals and firm response of firms, depending on the time period, which can be analyzed in three stages.

- Coordination as short response variable means
- Coordination as the means of production in response long run
- As innovation, research and development of long-term response, i.e, response.

### 9.19 Summary

- In short-term the demand and price of commodity decreases. The firm has to take the decision to continue production or stop it during the recession. In the short-term after stopping production, the firm still has to pay fixed costs such as building rent, interest, etc. Therefore, at the time of recession, the decline in commodity prices - is the same as the cost increases. The firm will opt only for continuing production. It will bear loss of fixed costs. Firm will continue production till the time it doesn't get variable costs. But if the firm will not receive variable costs then it will stop the production.

## 9.20 Keywords

Notes

- **Economic Cost:** Pay by rupees.
- **Private Cost:** The cost use by production.

## 9.21 Review Questions

1. What do you understand by the actual costs?
2. What do understand by the economic costs?
3. Social cost is different from individual cost. Explain it.
4. Describe the relationship between Average cost and Marginal cost.

## Answers : Self Assessment

- |             |            |              |          |
|-------------|------------|--------------|----------|
| 1. Monetary | 2. Options | 3. Contained | 4. (a)   |
| 5. (d)      | 6. (a)     | 7. (a)       | 8. (c)   |
| 9. True     | 10. True   | 11. False    | 12. True |

## 9.22 Further Readings



Books

1. **Microeconomics**—*Robert S. Predik, Daniel L. Rubenfield and Prem L. Mehta, Pearson Education, 2009, PBK, 7th Edition.*
2. **Microeconomics**—*David Basenco and Ronald Brutigame, Wiley India, 2011, PBK, 4th Edition.*
3. **Microeconomics**—*Shipra Mukhopadhyay, Annie Books, 2011.*

Notes

## Unit-10: Isoquant Curve

### CONTENTS

Objectives

Introduction

- 10.1 What is an Isoquant Curve?
- 10.2 Assumptions
- 10.3 Explanation
- 10.4 Slope of Isoquant Curve and Marginal Rate of Technical Substitution
- 10.5 Isoquant Map
- 10.6 Characteristics or Properties of Isoquant Curves
- 10.7 Iso-cost Line
- 10.8 Difference between Isoquant Curves and Indifference Curves
- 10.9 Producer's Equilibrium or Least Cost Combination of Factors
- 10.10 Conditions of Optimum Combinations of Factors or Least Cost Combinations
- 10.11 Principle of Substitution
- 10.12 Expansion Path
- 10.13 Isoquants and Returns to Scale
- 10.14 Isoquant Curve and Returns to a Factor
- 10.15 Summary
- 10.16 Keywords
- 10.17 Review Questions
- 10.18 Further Readings

### Objectives

After studying this unit, the students will be able to:

- Understand Isoquant Curves.
- Study the Iso – Cost Line.

- Understand the Production Equilibrium.
- Know the Principle of Substitution.

Notes

## Introduction

An Iso-cost line is a line which represents those various combinations whose costs are equal. In other words, this line represents various combinations of two factors which can be obtained by a firm on equal cost. Like various Isoquant curves, there are various iso-cost lines which represent various level of production.

### 10.1 What is an Isoquant Curve?

In the unit of Production Function and Principle of Production, we have already studied regarding a firm that it increases its production by using more variable factors or using all factors. In this unit, we would study about that firm which increases its production by using those two variable factors which are **substitutes** of each other. To get this, one production function is added with two variable factors. Suppose that these factors are labour and capital. The production function of firm can be represented like—

$$Y = f(K, L)$$

(Here Y = Production; K = Capital and L = Labour)

The variable factors are **substitutable** and the decreasing return to a factor law amplifies on each factors. In this functional function, Y is a dependent variable and L and K are independent elements. So if we draw relation between all three elements (Labour, Capital and Production) then this type of drawing can only be obtained by **three dimensional** drawing, which is very complex. To draw this image it is easier to suppose production Y as stable element. Then this functional relation states that how stable level of production is created by using the combinations of two variable factors—capital and labour. The Isoquant curve is called the geometric representation of this **functional relation**. **The Isoquant Curve is a technical relation showing how inputs are converted into outputs. It is also an efficiency relation showing the maximum amount of output with a given amount of inputs. In other words, if the quantity of factors and prices are given then it represents the minimization of cost or the combination of factors in its optimum level.**

**Isoquant or Isoproduct has been derived from two words, Iso = Equal and Quant = Quantity or Product = Output.** So it means equal quantity or equal production. To produce a product, factors are required. These factors can be substituted to each other. For example, production of 100 watches can be produced by using 90 units of capital and 10 units of labour. So the production of 100 watches can also be made by using other combinations of labour and capital like 60 units of capital and 20 units of labour or 40 units of capital and 30 units of labour. If the combinations of two factors are represented into a curve to produce an equal amount, then this type of curve is called **Isoquant or Iso-product curve**. **Isoquant curve is that curve which shows the different possible combinations of two factor inputs yielding the same amount of output.** The Isoquant curves can also be called equal product curve or iso-product curve or marginal curve. The Isoquant curve is called marginal curve because it amplifies the marginal curve analysis of theory of consumption to theory of production.

According to Ferguson, "An Isoquant is a curve showing all possible combinations of inputs physically capable of producing a given level of output."

In the words of Peterson, "An Isoquant curve may be defined as a curve showing the possible combinations of two variable factors that can be used to produce the same total output."

Notes

## 10.2 Assumptions

The main assumptions of Isoquant curve are—

1. **Two Factors of Production:** To draw these curves, in view of simplicity, it assumes that only two factors of production are used to produce a product. Both the factors are variable.
2. **Constant Technique:** It assumes that the production technique is constant or given.
3. **Divisible Factor:** It assumes that the factor of production is divisible or it can be used in small quantity.
4. **Possibility of Technical Substitution:** It must be assumed that there is possibility of technical substitution between two factors. Means the production calculation is **Variable Proportion Type** and not **Fixed Proportion Type**.
5. **Efficient Combination:** It also assumes that in given technique, the factor of production is used in its efficient combination.

**Two Basic Assumptions  
of Isoquant Curves**

- (1) Both the factors using in production are substitute to each other.
- (2) Decreasing Returns to factor theory amplifies in production.

## 10.3 Explanation

The Isoquant curve can be described by following table which represents various combinations of two factors (labour and capital) for production.

<b>Table 1: Isoquant Schedule</b>			
<i>Combination</i>	<i>Product (Watch)</i>	<i>Capital (K)</i>	<i>Labour (L)</i>
A	100	90	10
B	100	60	20
C	100	40	30
D	100	30	40

Above table indicates that 100 watches can be made by following combinations of labour and capital—

- (A) 90 units of capital and 10 units of labour
- (B) 60 units of capital and 20 units of labour
- (C) 40 units of capital and 30 units of labour
- (D) 30 units of capital and 40 units of labour

*The Isoquant curve represents various combinations of capital and labour by which equal amount of production occurs.*

In the above table, the combination of capital and labour can be represented by figure or graph too. In figure 10.1 capital is shown on axis OY and labour is shown on axis OX. Point A represents that 100 units of watches can be produced by 90 units of capital and 10 units of labour. While point B indicates that this same quantity of watches can be produced by 60 units of capital and 20 units of labour. Thus the point C indicates that the production of 100 watches can occur by 40 units of capital and 30 units of labour. While point D represents that the same quantity of watches can be produced by 30 units of capital and 40 units of labour. Thus A, B, C and D represent various combinations of labour and capital which produce the similar quantity of watches (100). So the IQ curve which comes by adding the point A, B, C and D is called **Equal Product Curve** or **Isoquant Curve**. This Isoquant curve describes that to produce a fixed quantity of product, there are various combinations of factors.

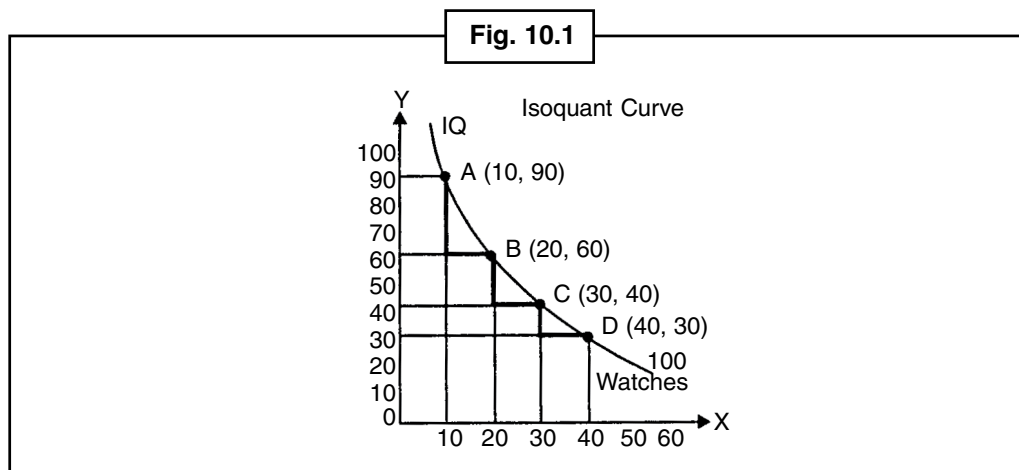

### Self Assessment

#### Fill in the blanks:

1. Iso-product curve is the curve which represents various combinations of factors of .....
2. The Isoquant curves can also be called equal product curve or iso-product curve or ..... curve.
3. Diminishing returns to ..... amplifies in production.

## 10.4 Slope of Isoquant Curve and Marginal Rate of Technical Substitution

The slope of Isoquant curve is substitution for a factor to another. It indicates that a factor can be substituted to another by making production stable. By Isoquant curve, we can get the data of technical substitution of a production (labour) in another product (capital).

#### What is the Marginal Rate of Technical Substitution?

*This is the rate at which the means of production to a stable level is the replacement for other means.*

Because of this, the slope of Isoquant curve is also called **Marginal Rate of Technical Substitution (MRTS)**. For factor X, the marginal rate of technical substitution rate for factor X is the rate where Y is substituted by X while keeping production constant. According to Lipsey, "The marginal rate of technical substitution may be defined as the rate at which one factor is substituted for another with output held constant."

If factor Y is capital and factor X is labour then for capital, the marginal rate of technical substitution rate of X is the rate where labour can be substituted by capital while keeping the production level stable. In Fig. 10.1, in point A, for example, the production of 100 units occurs by 90 units of capital and 10 units of labour in point B, 60 units of capital, 20 units of labour produce same output. The slope of Isoquant curve between A and B is 30 units of capital and 10 units of labour, it means that in point A, without changing the production level, for 30 units of capital, 10 units of labour can be substituted. MRTS can be described mathematically as—

$$\text{MRTS} = \frac{\Delta K}{\Delta L}$$

(MRTS = Marginal Rate of Technical Substitution;  $\Delta K$  = Changes in Capital;  $\Delta L$  = Changes in labour).

**Notes** In other words, by using little more labour, whatever production increases is similar to the loss of production by using little less capital. The production is equal to  $\Delta TP$  by increasing of  $\Delta L$  quantity of labour. Thus the production is low by  $\Delta TP$  due to  $\Delta K$  amount of less capital.

So, 
$$\frac{\Delta TP}{\Delta K} = \frac{\Delta TP}{\Delta L} \quad \dots(i)$$

We know, 
$$\frac{\Delta TP}{\Delta K} = MP_K$$

or 
$$\Delta TP = MP_K \times \Delta K \quad \text{(Increase in production)}$$

$$\Delta TP = MP_L \times \Delta L \quad \text{(Loss in production)}$$

$$MP_K \times \Delta K = MP_L \times \Delta L$$

(Here  $MP_L$  = Marginal physical product of labour,  $MP_K$  = Marginal physical product of capital)

$\therefore \frac{\Delta K}{\Delta L} = \frac{MP_L}{MP_K}$

So the rate of technical substitution is equal to the rate of marginal products of capital and labour. The marginal rate of technical substitution between capital and labour has downward nature. This means for the capital, MRTS of labour decreases. More labour is substituted for every extra unit of capital.



*Notes* The Isoquant curve is the curve which represents the various combinations of factors which do the same amount of production.

### 10.5 Isoquant Map

The combination of aggregate Isoquant curve represented by a figure is called Isoquant Map as it is presented in Fig. 10.2. Isoquant map refers to the family of Isoquant curves placed in one diagram. It shows a set of isoquants, one for each level of output.

*The high level of production is represented by a right hand side curve of an Isoquant curve.*

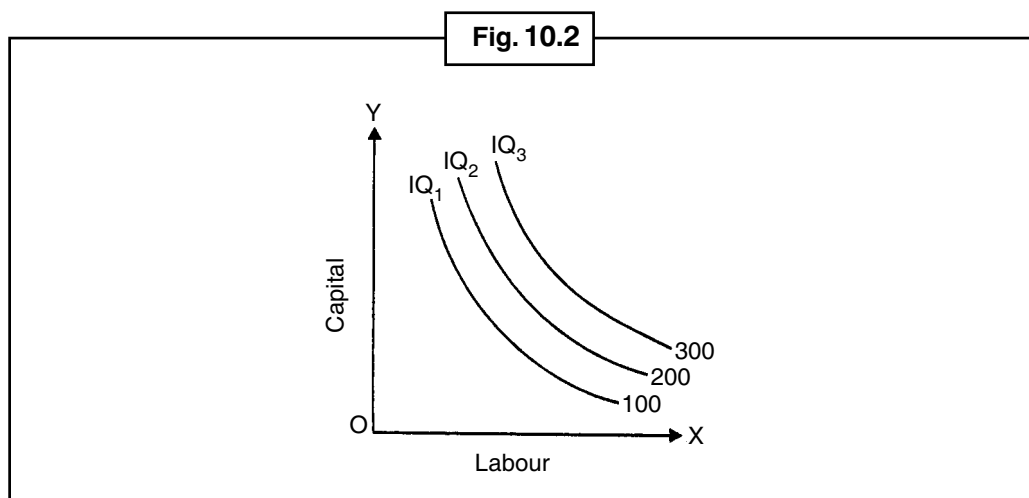

As much as production level increases, the Isoquant curve will be far from its original point.  $IQ_1$ ,  $IQ_2$  and  $IQ_3$  represent the various levels of production. An Isoquant curve which is in right side of the other curve indicates high level of production. So the  $IQ_2$  curve is from  $IQ_1$  and  $IQ_3$  curve indicates more production than  $IQ_2$  curve. The high level of production will happen as much as the Isoquant curve is high. But every Isoquant curves represent the various quantities of variable factors.

## 10.6 Characteristics or Properties of Isoquant Curves

The characteristics of Isoquant curves match with indifference curve. These characteristics are -

1. **Isoquant Curves Slope Downwards:** An Isoquant curve, as shown in Fig. 10.3, is falling downward from left to right. In other words, its slope is **negative**. The reason behind this is **substitution** of factors. If we use a factor to get a fixed amount of production, then the second factor will be less used. If both of the factors simultaneously will be used less or more, then total production will not be the same. It will either be less or more. Table 1 indicates that to produce 100 watches, more capital means 90 units are used and then it combines with lesser amount of labour i.e. 10 units of labour. Thus to get 100 units of similar production, if we use less capital i.e. 30 units then it will combine with more units of labour i.e. 40 units of labour. **The downward sloping of an Isoquant curve is substitution of factors.** The factors of production is substituted to each other so to get equal amount of production if using less amount of a factor, then another factor is used in a greater way. This is the reason that the slope of Isoquant curve is from above to below (downward).

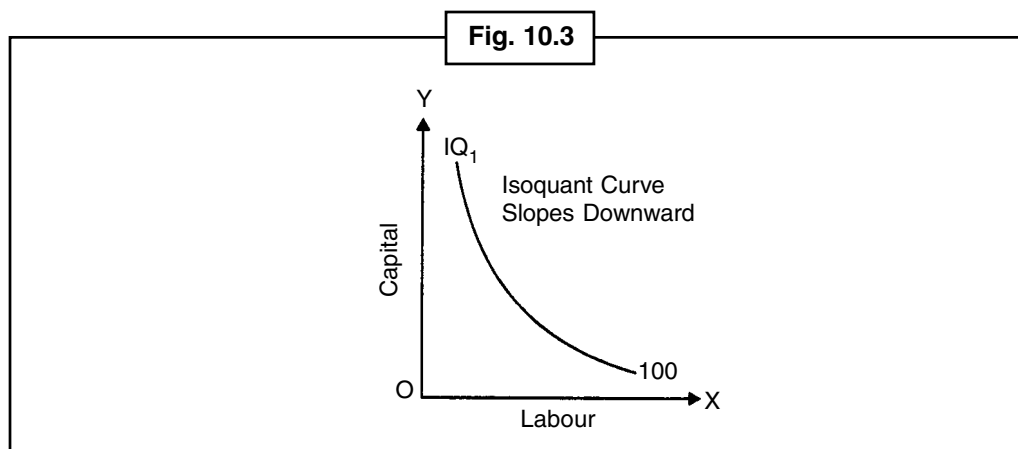

2. **Isoquant Curves are Convex to the Origin:** The Isoquant curve is always convex to its original point O as shown in Fig. 10.4. It means the factor is not a **perfect substitute**. It means the marginal rate of technical substitution of product has decreased. Table 1 indicates that to use 10 units of labour 30 units of capital is withdrawn and to use extra 10 units of labour, 20 units of capital is substituted. The level of production is equal on an Isoquant curve when the capital is withdrawing to use every next unit of labour. In Fig. 10.4, the Isoquant curve's point B

### Why the slope of Isoquant Curve is Convex?

*The reason behind this is marginal rate of technical substitution.*

clarifies that to use 30 units of capital is withdrawn to use 10 extra units of labour. Thus the MRTS of labour for capital is 3:1. It would be 2:1 on point C. So, marginal rate of technical substitution has nature of fall. So IQ curve is convex to the origin.



Notes

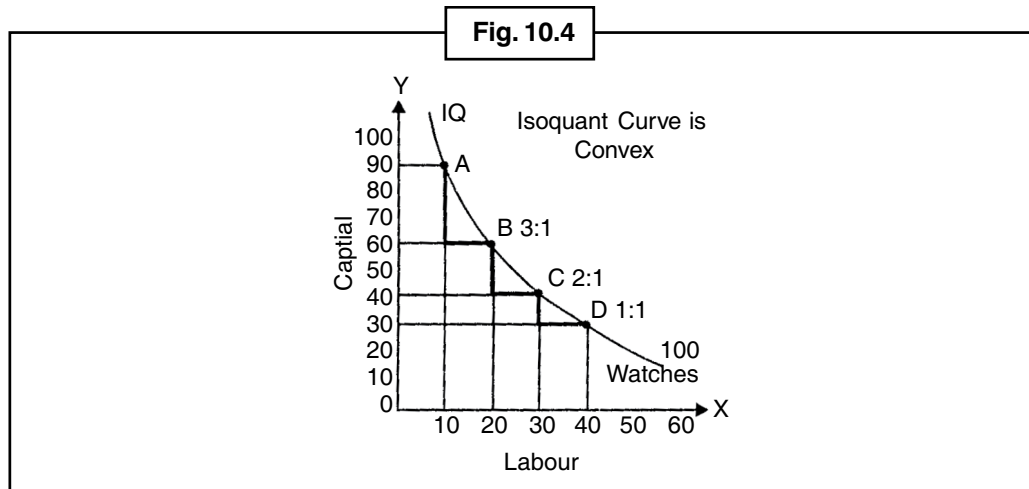

3. **Two IQ curves cannot intersect each other:** We know that the Isoquant curve represents the unique level of production and every point indicates the same level of production. If two Isoquant curves intersect each other then the equal point will get in both the curves. This equal point will represent two different levels of production. This is opposite to assumption of Isoquant curve. Every point in Isoquant curve represents equal production. This is described by Fig. 10.5.

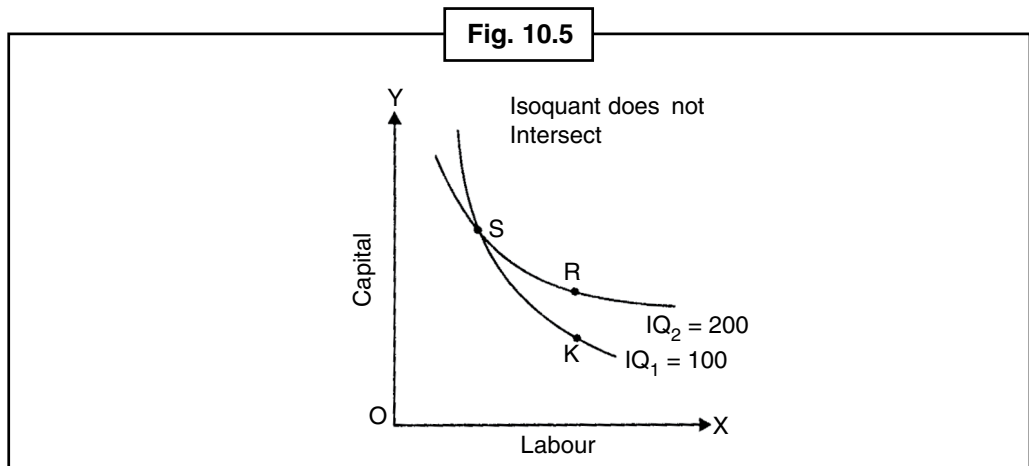

$IQ_1$  curve indicates 100 units of production while  $IQ_2$  curve indicates 200 units of production. Both curves cut itself at point S. We know that all the points are equal to each other on Isoquant curve which represents the equal amount of production. So as per Fig. 10.5—

$$S = K = 100 \text{ units on } IQ_1, \quad S = R = 200 \text{ units on } IQ_2, \quad \therefore K = R$$

**Self Assessment**

**Multiple choice questions:**

4. The slope of Isoquant curve is .....
- (a) from up to down
  - (b) from down to up
  - (c) from right to left
  - (d) from left to right

5. The Isoquant curve is ..... on its original point.
  - (a) vertical
  - (b) horizontal
  - (c) convex
  - (d) down
6. Two Isoquant curves represent ..... level of production.
  - (a) two units
  - (b) one unit
  - (c) three units
  - (d) four Units
7. In equilibrium point, the iso-cost line is ..... to Isoquant curve.
  - (a) touching Point
  - (b) original Point
  - (c) middle Point
  - (d) upper Point
8. The diminishing returns to factor are due to ..... of factor.
  - (a) losses
  - (b) demerits
  - (c) profit
  - (d) increment

Two Isoquant curves indicate two different levels of production. If the curves intersect each other, it means the cutting point will represent the equal production which would be wrong from technical point of view.

But this is not possible because point K indicates 100 units of production while point R indicates 200 units of production. Thus S represents 100 and 200 units of production and this is technically wrong. So the intersect of Isoquant curve represents absurd and contradictory status. So two Isoquant curves will not intersect each other.

4. **The higher the Isoquant curve higher will be the level of output:** Higher are the isoquant curves from each other, higher will be the production. It means that higher Isoquant curve is based on the higher level of factors of production. This is represented in Fig. 10.6. In this figure, higher Isoquant curve  $IQ_1$  indicates the higher production i.e. 200 units. And lower Isoquant curve  $IQ$  represents 100 units of production. To produce higher represented  $IQ_1$  units (200) extra factors ( $OL_1 + OK_1$ ) are used. While to produce lower  $IQ$  units, the lower factors ( $OL + OK$ ) are used. So the higher curve  $IQ_1$  indicates 200 units while lower curve  $IQ$  indicates the lower quantity i.e. 100 units.

Fig. 10.6

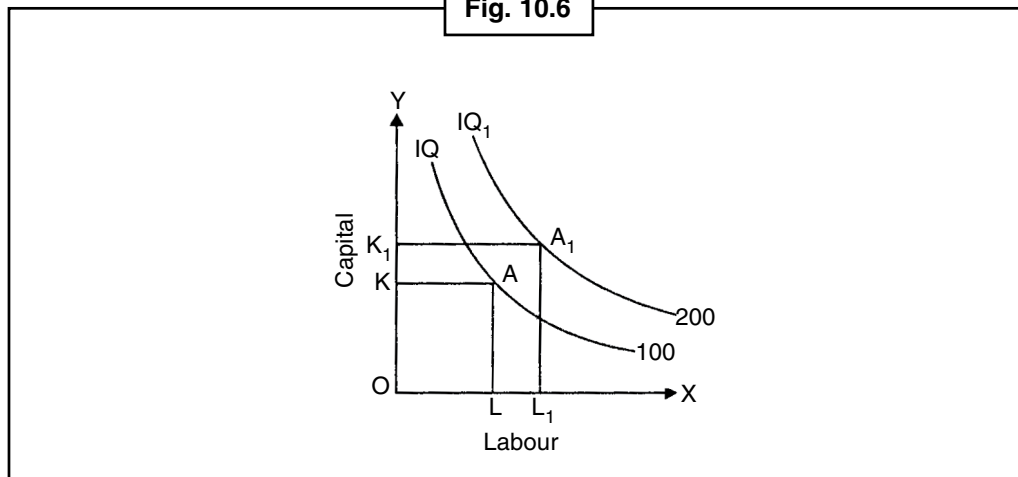

Did u know? The slope of an Isoquant curve is substitution of factors.

Notes

### 10.7 Iso-cost Line

An iso-cost line is the line which represents those various combinations whose total cost is equal. In other words, this line represents the various combinations of two factors which a firm can get in equal cost. Iso-cost lines are various like isoquant curves, which represent various levels of production. iso-cost line may be defined as the line which shows different possible combinations of two factors that the producer can afford to buy his total expenditure to be incurred on these factors and price of the factors.

#### Explanation

The assumption of iso-cost line can be described with Table 2 and Fig. 10.7. Suppose that producer has only ₹ 100 units to buy labour and capital. The cost per unit of labour is ₹ 10 and cost per unit of capital is ₹ 20.

Table 2: Alternative Factor Combination		
Total Expenditure (in ₹)	Labour $L_p = ₹ 10$	Capital $L_k = ₹ 20$
100	10	0
100	0	5
100	4	3
100	2	4

The producer has following options –

*By sloping of iso-cost line, factor price average can obtain. But the level of iso-cost curve shows the budget limit of producer. High iso-cost line shows more cost to produce a product.*

- (i) To spend all his money in labour he can establish 10 units ( $\frac{100}{10} = 10$ ).
- (ii) To spend all his money in capital he can buy 5 units ( $\frac{100}{20} = 5$ ).

(iii) To spend all his money in both labour and capital he can buy all possible combinations of capital and labour like (4, 3) (2, 4) etc.

In Fig. 10.7, labour is shown on axis OX and capital is on axis OY. The points A, B, C and D represent various combinations of capital and labour, which can be bought at ₹ 100. Point A indicates the five units of

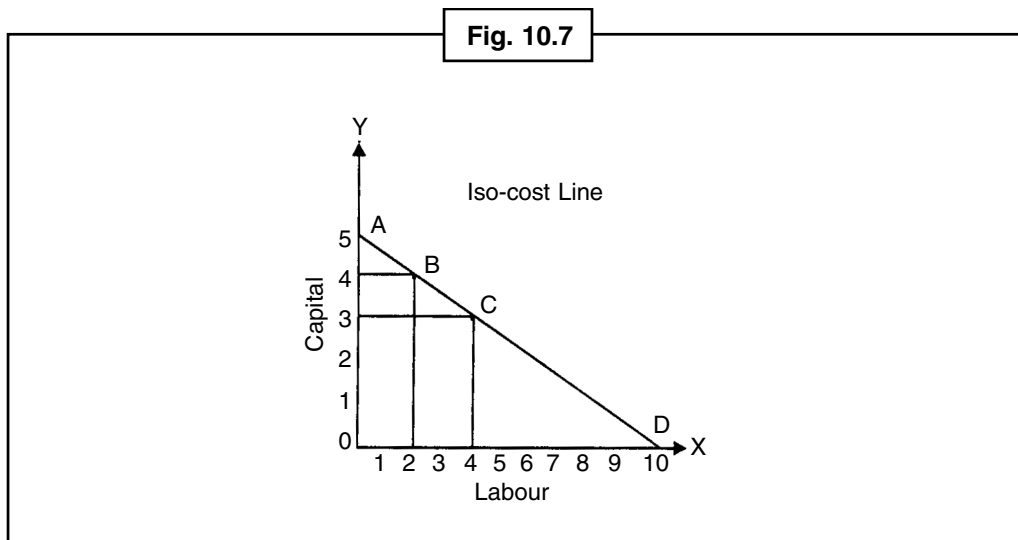

capital and zero units of labour, while point D indicates ten units of labour and zero units of capital. Point B indicates four units of capital and two units of labour while point C indicates four units of labour and three units of capital.

The sloping of iso-cost line is the average of pricing. To represent labour on axis OX and capital on OY, the sloping of any iso-cost line would be following –

$$\text{Slope of iso-cost Line} = \frac{\text{Cost of Labour}}{\text{Cost of Capital}}$$

(Note: The cost of labour represents the cost of capital and the cost of capital represents the cost of labour.)

## 10.8 Difference between Isoquant Curves and Indifference Curves

The utilization of Isoquant curves in production theory is similar to indifference curves in demand theory. After studying the Isoquant curves, we reach to the point that these curves are similar to indifference curves but there are some differences between these two curves –

- (1) An indifference curve represents the combinations of two products which give **equal satisfaction**. Apart from this, Isoquant curve represents various combinations of two factors by which a firm gets equal production.
- (2) The Isoquant curve indicates the equal level of production which can be measured. The indifference curve represents the **equal level of satisfaction** which cannot be measured.
- (3) The Isoquant curve represents the combinations of variable things while the indifference curve represents the **combination of products**.
- (4) The Isoquant curve gives the knowledge of economical and uneconomical region of production. The indifference curve does not give the knowledge of economical and uneconomical region of consumption.
- (5) The slop of an Isoquant curve fluctuates by the technical possibility between the factors of production. This depends upon the marginal rate of technical substitution (MRTS), while the slope of an indifference curve depends upon the MRS of two consumptive products from consumer.

**Watson** has given true conclusion as, “Isoquant curves do indeed look like indifferent curves. Their geometric properties are similar. Their economic analysis is parallel. But one great difference separates them. Indifference curves are subjective. What goes on in consumer’s mind has been assumed. In contrast Isoquant curves are objective, they can be measured in practice as well as in principle.”

## 10.9 Producer’s Equilibrium or Least Cost Combination of Factors

**The producer’s equilibrium refers to a situation in which a producer maximizes his profits.** In other words, a producer produces a constant quantity of product with the help of minimum combination of cost and factor. To use this minimum cost combination is also called optimum combination.

**Optimum or minimum cost combination is the combination in which –**

- (i) **The production which is got from fixed level of factors is maximum or**
- (ii) **The cost is minimum for production in fixed level**

**Notes**

The factors or equilibrium of production can be represented by Fig. 10.8. Suppose that a producer wants to produce pens with total investment of ₹ 1500. To produce pens, he needs labour and capital as two factors of production. The one unit of labour costs ₹ 50 while one unit of capital costs ₹ 75. He can produce with 30 units so labour plus without capital or 20 units of capital plus without labour. He would love to mix the optimum combination of both the factors. This optimum combination is represented by point E when he will use 10 units of capital and 15 units of labour ( $10 \times ₹ 75 + 15 \times ₹ 50 = ₹ 1,500$ ). **The point E is touching point of Isoquant curve IQ and equal cost curve AB.** The producer can move above and below the Isoquant curve IQ and equal cost curve AB. If he goes to point M or N of Isoquant curve IQ, then he would find himself on above equal cost line CD, it means he needs to pay more for producing initial amount of pen (100) rather than investing the fixed level of ₹ 1500. In other words, to produce 100 pens, the cost is minimum at point E. So the point E will represent the combination of minimum cost.

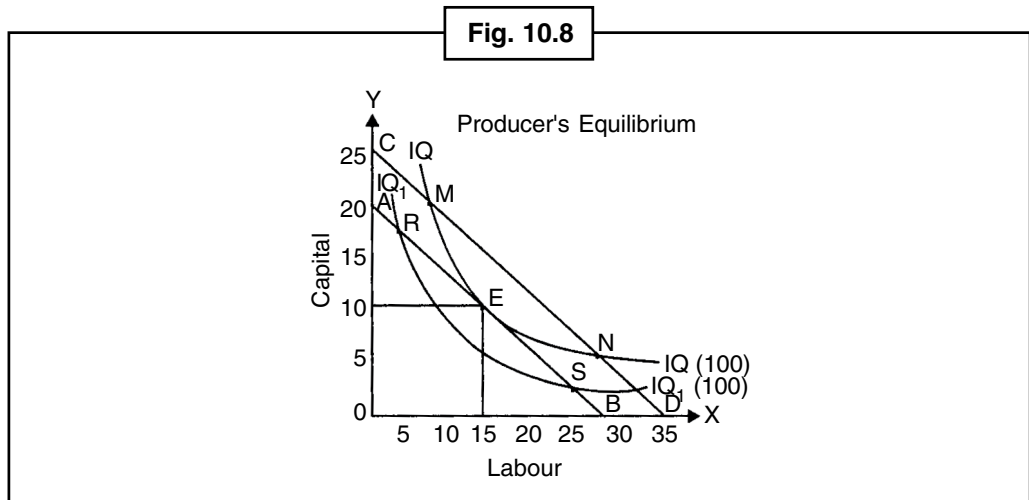

In contrast, if he wants to buy the combination of point R or S below Isoquant curve IQ<sub>1</sub> then he can only to produce 50 out of initial 100 pens on initial investment of ₹ 1500. In other words, point E represents more production from a fixed investment. So **producer will be in equilibrium only at point E.**

### 10.10 Conditions of Optimum Combinations of Factors or Least Cost Combinations

Following are the conditions of optimum combinations of factors or least cost combinations –

1. **The iso-cost line should be touching line for Isoquant curve on flat point.** The slope of Isoquant curve and iso-cost line is equal at touching point. The slope of iso-cost line is the rate price of factors. The slope of Isoquant curve is the marginal rate of factors. This is also called the Marginal Rate of Technical Substitution.
2. **iso-cost curve is convex to the origin on touching point or  $MRTS_{LK}$  is falling.**

*The touching point of iso-cost curve and Isoquant curve represents the maximum quantity of production by a fixed combination of inputs or represents the minimum cost combination of inputs.*

(i) **The slope of Isoquant curve = The slope of iso-cost Line**

$$MRTS_{LK} = \frac{\Delta K}{\Delta L} = \frac{MP_L}{MP_K} = \frac{P_L}{P_K}$$

(ii) **iso-cost curve should be convex to the origin on touching point or  $MRTS_{LK}$  should be falling.**

(Here  $\Delta K$  = Changes in capital,  $\Delta L$  = Changes in labour,  $MP_L$  = Marginal product of labour,  $MP_K$  = Marginal product of capital,  $P_L$  = Labour costs,  $P_K$  = Cost of capital,  $MRTS_{LK}$  = Marginal rate of technical substitution of labour and capital)

### 10.11 Principle of Substitution

According to principle of substitution, the process of production changes by changing the factors of production. **Relatively, cheaper factor is substituted for the other factor or more of the relatively cheaper factor is used and less of the other.**

The pricing affects more to the production factors and distribution of factors in production process.



*Illustration:* Let's assume a producer wants to produce 100 pens. Also assume that in equilibrium state (by satisfying the law of minimum cost or profit maximization) 10 units of capital and 15 units of labour are used. Total expenditure is ₹ 1500 if the price is ₹ 75 per unit for capital and ₹ 50 per unit for labour.

This can be represented as –

Production	Inputs		Price		Total expenditure (in ₹)
	K	L	$P_K$	$P_L$	
100	10	15	75	50	$750 + 750 = 1,500$

Now assume that the cost of labour ( $P_L$ ) is increased from ₹ 50 to ₹ 75. So to produce the similar rate (with constant combination of inputs), the status would change as following –

Production	Inputs		Price		Total expenditure (in ₹)
	K	L	$P_K$	$P_L$	
100	10	15	75	75	$750 + 1125 = 1,875$

Thus if there is no change in inputs, then the cost of production increases from ₹ 1500 to ₹ 1875 while the production level is same. Figure 10.9 describes this state.

If equal numbers of factors are used then the cost would be ₹ 1875 ( $75 \times 10 + 75 \times 15$ ). So the new price of pens for 100 units with old combination of factors would be ₹ 1875 which was earlier ₹ 1500.

Fig. 10.9

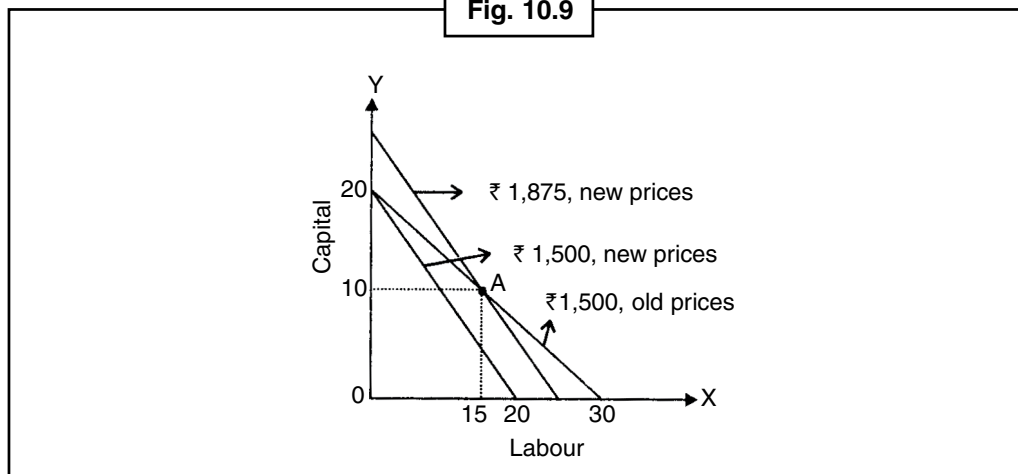

**Notes**

If the combination of minimum cost of inputs would be retrieved then the producer would certainly substitute capital in respect to labour. Because when the price of labour increases, all matter remain same, then capital gets cheaper. Initially, price average was  $P_L/P_K = 50/75$ , now it is  $75/75$ , it means capital is cheaper than labour.

The minimum cost combination would definitely change now. Now how much should invest in labour and capital so that the expenditure becomes less?

Definitely, this matter depends on the technical substitution rate between labour and capital. This imaginary position is described by Fig. 10.10.

To produce similar 100 units of pen, 10 units of labour and 18 units of capital are sufficient. However the cost of both labour and capital is now ₹ 75, but capital is more efficient than labour. So now more capital and less labour will be used. With this new combination, the minimum production cost to produce 100 pens is –

$$(18 \times 75 + 10 \times 75) = ₹ 2,100$$

$E_1$  is the new point for the new factors of profit maximization in which 18 units of capital, which is comparatively cheaper, and 10 units of labour, which is comparatively costly, and undoubtedly here is no change in capital.

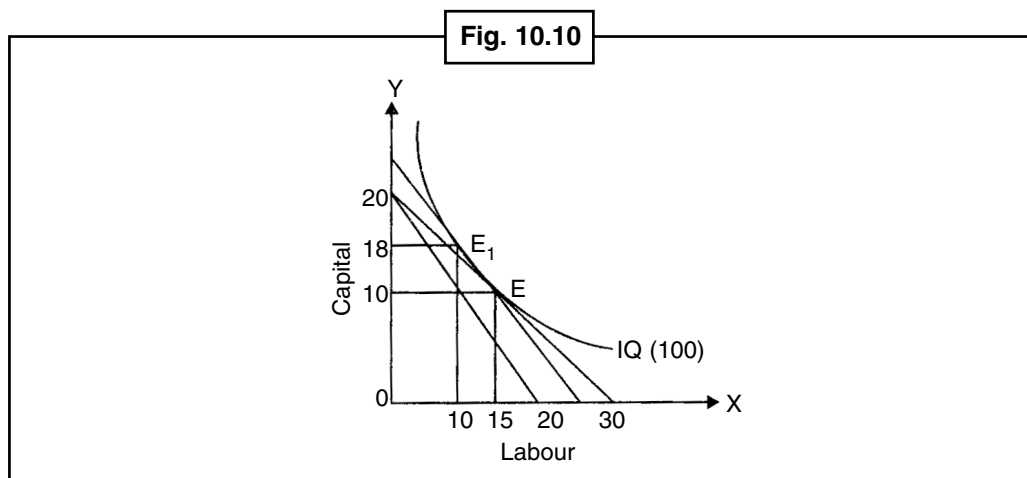

So we can say that as soon as the cost of labour increases, capital gets cheaper. Thus the Principle of Substitution happens as capital is substituted for labour. When the price of any factor is changed then the production by old combination of factors gets costlier or inefficient.

**10.12 Expansion Path**

If the capital of firm rises then it will want to increase his production. The quantity of production can rise when there is no increment in price of factors as well as cost due to rise of capital. The total production level is increased by increasing the capital of firm and firm can produce production in various levels by using various combinations of factors. The firm will use what point in the various levels of production can be identified by **Expansion Path**. **Expansion Path refers to the locus of all such points that show least cost combination of factors corresponding to different levels of output.** In other words, Expansion Path indicates that when the firm increases its production level then which optimum combination of factors is used. Since the expansion of firm depends upon the status of production, so expansion path is also called Scale Line.

Notes

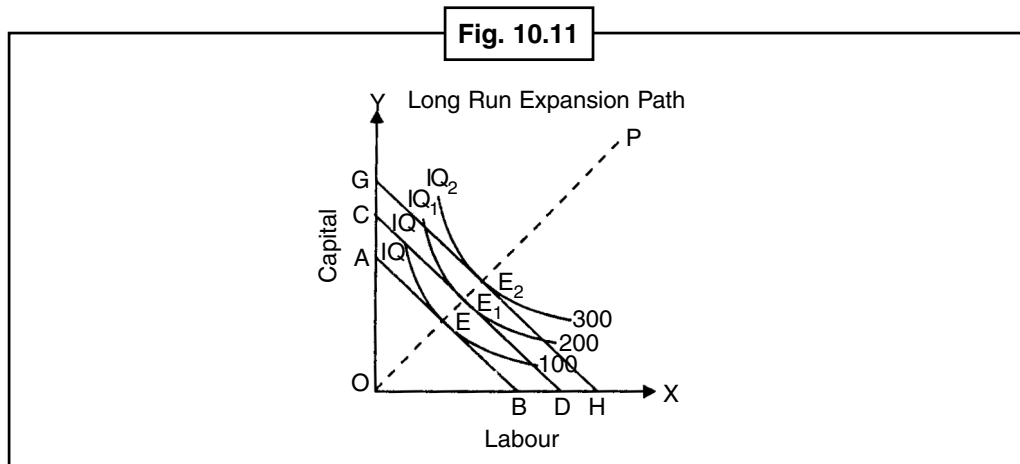

According to Stonier and Hague, "Expansion Path is that line which reflects least cost method of producing different levels of output, when factor prices remain constant."

Expansion Path is of two types –

- (1) **Long Run Equilibrium Path:** All the factors of production are variable in long run. So labour (L) and capital (K) can be changed. Suppose that both the factors are increased in the same way, then the expansion of firm, as shown in Fig. 10.11, will be a straight line OP. By increasing both labour and capital, the firm will be diverted from E to E<sub>1</sub> and E<sub>2</sub>. The production by these points are 100, 200 and 300 respectively.

**Study of Figs. 10.11 and 10.12**  
*OP is long run expansion path while L and Y both are variables. In contrast, HR is short run expansion path while L increases but K is constant.*

Thus, **Expansion Path is the locus of all points of optimum combinations of L and K corresponding to different levels of output.**

- (2) **Short Run Expansion Path:** In short run, any factor of production like capital (K) is stable. So the quantity of production can be increased by increasing other factors of production like labour (L). As shown in Fig. 10.12, the constant capital is OH. By it, the production can increase by using more quantity of labour. Points E, E<sub>1</sub> and E<sub>2</sub> which indicate various levels of production represent the unique combinations of capital and labour. All these points can be merged by HR curve.

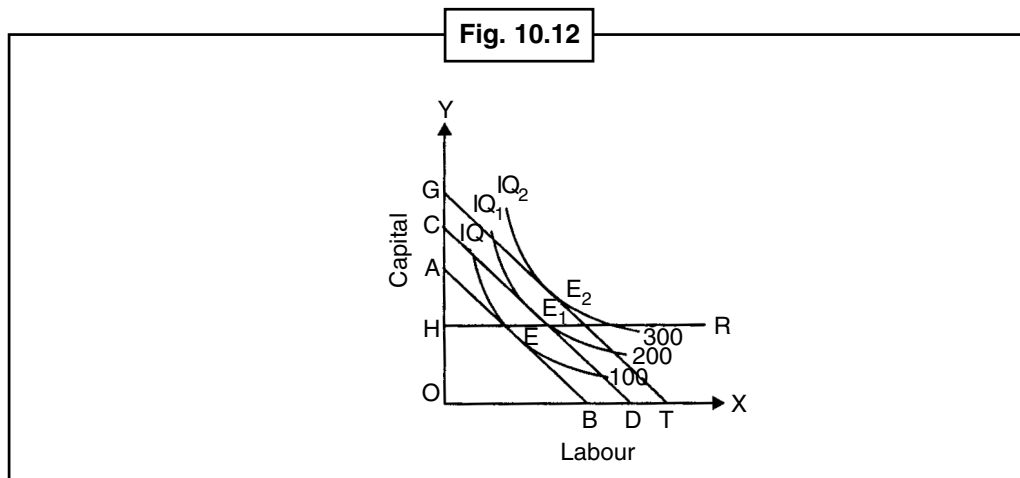



**Notes**

Thus, HR is a short run expansion path. It must be known that point E of Fig. 10.12 is a touching point of Isoquant curve and iso-cost curve and it is equal to long run point. Point  $E_1$  and  $E_2$  of Fig. 10.12 are not equal to point  $E_1$  and  $E_2$  of Fig. 10.11, the reason behind this is that the average of labour-capital is not constant even the capital is constant. The averages are changed as per production.

### **10.13 Isoquants and Returns to Scale**

To describe and drawing of Returns to Scale, economists have frequently used Isoquant curve analysis. We have already described Returns to Scale in the units of Production Scale and Production Law. We already know that returns to scale means the changes in production of a firm while in a given technique, all the factors of production are changed in their ratio. The Returns to Scale is of three types: (i) Increasing Returns to Scale, (ii) Decreasing Returns to Scale and (iii) Constant Returns to Scale. By using iso-cost technique all three types can be described as below:

#### **Assumptions**

To describe the returns to scale by using equal production technique is based on following assumptions:

- (i) Firm is using only two factors of production, labour and capital.
- (ii) The combination of labour and capital is used in a stable average.
- (iii) There is no change in price of factors, so the ratio of price-factor always stable  $\left(\frac{P_L}{P_K}\right)$ .
- (iv) The production technique occurs stable.

#### **Self Assessment**

**State whether the following statements are True/False:**

9. To double the factor is to double the production.
10. The combination of labour and capital is used in a fixed ratio.
11. The production technique is stable.
12. Expansion path is the line which shows the minimum cost theory of producing various levels of production when the price of factors remains stable.

#### **Explanation**

1. **Increasing Returns to Scale:** The increasing returns to scale is the situation where the quantity of product increases in a ratio of increasing factors. In other words, if the average production increases by increasing fixed changes in factors, it is the stage of increasing returns to scale. In increasing returns to scale, if the factors of production are doubled, then the quantity of production gets more than double. As shown in Fig. 10.13, as soon as the labour and capital doubles from 2 to 4 units, then the production occurs just double i.e. from 50 units to 120 units. The increasing return to scale is also called Economies of Scale.

Fig. 10.13

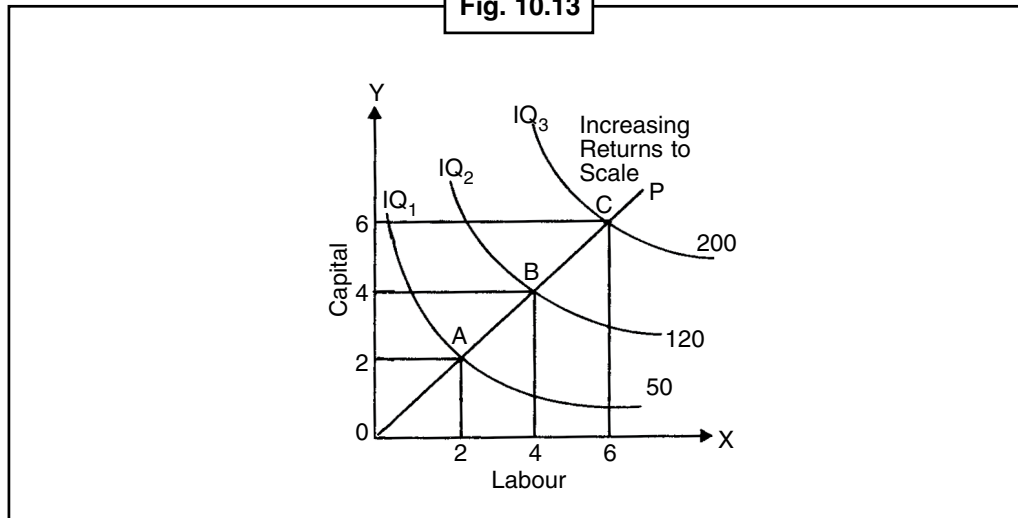

2. **Decreasing Returns to Scale:** Decreasing returns to scale is the situation where the ratio of production does not increase even when the factors increase. In other words, if the changes happen with the factors in a limited quantity, the ratio of production does not increase, and then this is the condition of decreasing returns to scale. Figure 10.14 indicates that if the factor of production gets double then the production does not double. This figure clarifies that when labour and capital get doubled, from 2 to 4 units, then the production does not double and it increases from 50 units to 80 units. The reason behind this is decreasing returns to scale. Decreasing returns to scale happens due to diseconomies of scale.

Fig. 10.14

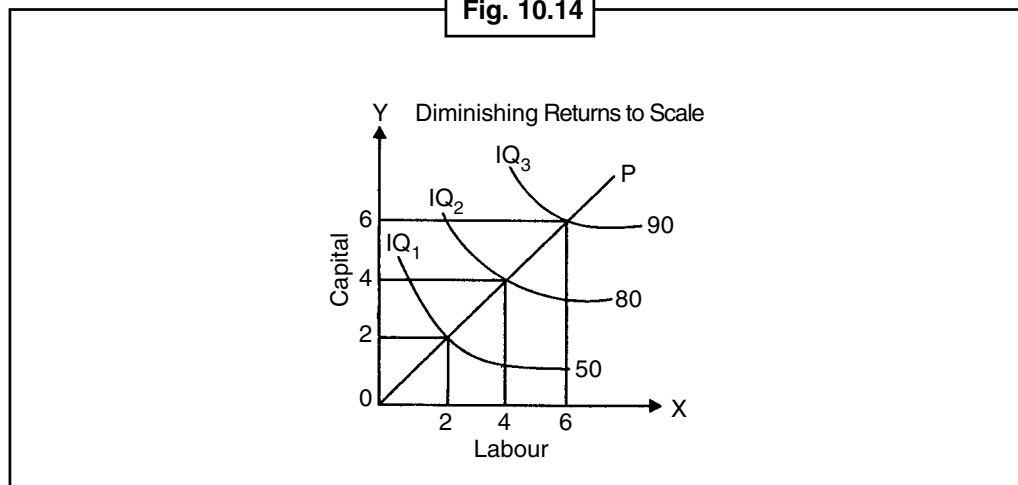

3. **Constant Returns to Scale:** Constant returns to scale is the situation where the extended ratio in production is equal to extended ratio of factors. In other words, constant returns to scale means the ratio of increment in factors and increment in production is same. If doubles the factors, production is automatically doubled. It is shown in Fig. 10.15. Here factors and production are increasing in similar ratio. Means when factors increase i.e., from 2 to 4 units, then production is double i.e., from 50 units to 100 units.

Notes

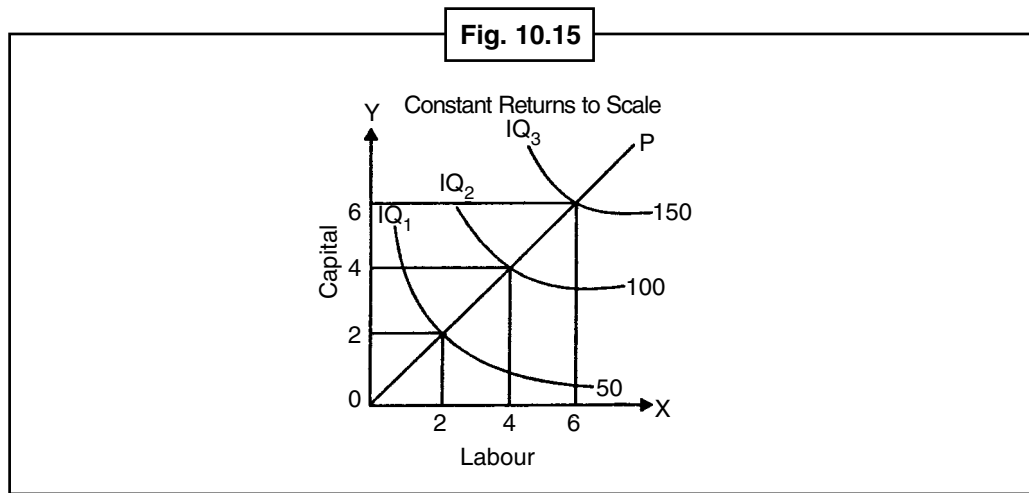

**10.14 Isoquant Curve and Returns to a Factor**

Returns to a factor means the change in production even if changes in a single factor and others factors are stable. Like returns to a scale, returns to a factor is also of three types—Increasing Returns, Constant Returns and Decreasing Returns. Returns to a factor can be described by iso product technique.

Suppose that labour is a variable factor while capital is a constant factor. Returns to factor of variables can be described as follows—

1. **Increasing Returns to a Factor:** Increasing Returns to a Factor means the total production increases in increased ratio using variable factors like extra units of labour. Figure 10.16 represents an increasing returns to a factor.

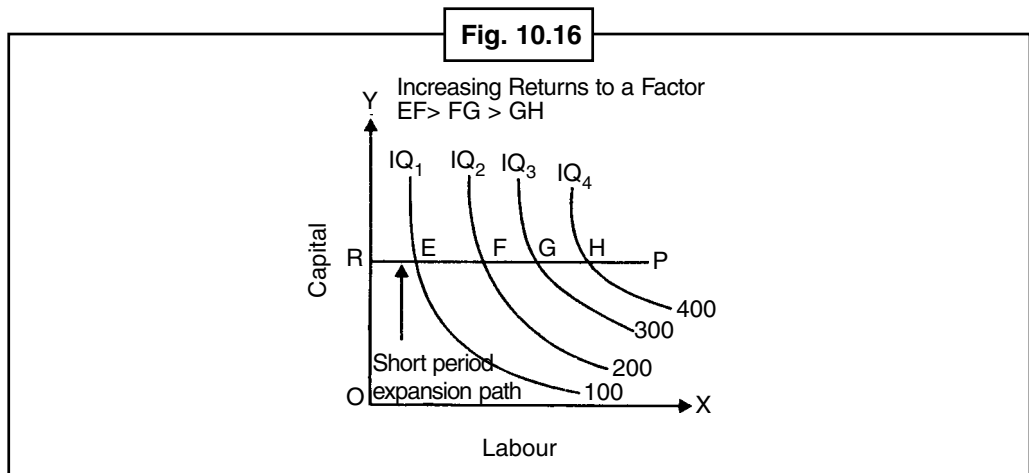

In Fig. 10.16, capital is stable in unit OR. Line RP indicates that to rise in production, how can the quantity of labour be used. This is called Output Path. The iso-product curves for the 100, 200, 300 and 400 units represent that the increase in production is happening by alternatives of 100 units. This iso-product curve cuts production path RP on point E, F, G and H. The differences between iso-product curves are decreasing; it means there is low labour needed for alternatives of 100 units. This means

increasing of labour. From Fig. 10.16 it is clear that the difference between EF is greater than FG and the difference between FG is greater than GH. Means,

$$EF > FG > GH$$

Notes

It means that to increase 100 units of production can be got by labour in decreasing order. Suppose that EF is 20 units of labour and FG is 10 units of labour. Then, from E to F, other 100 units of production can be occurred by 20 extra units of labour. From F to G, other 100 units of production can be occurred by 10 extra units of labour. Thus the production path RP indicates that when production increases then the marginal production of labour increases.

2. **Diminishing Returns to a Factor:** Diminishing Returns to a Factor is the situation where the total production increases in decreasing rate by increasing the numbers in variable factors. Figure 10.17 indicates the diminishing returns to a factor. When capital is stable in RP and production increases by using only extra units of labour then the differences between iso-product curves make larger means to produce 100 alternative units, more labour is required. It means the marginal production of labour is decreased. The difference between EF is less than FG and the difference between FG is less than GH. Means,

$$EF < FG < GH$$

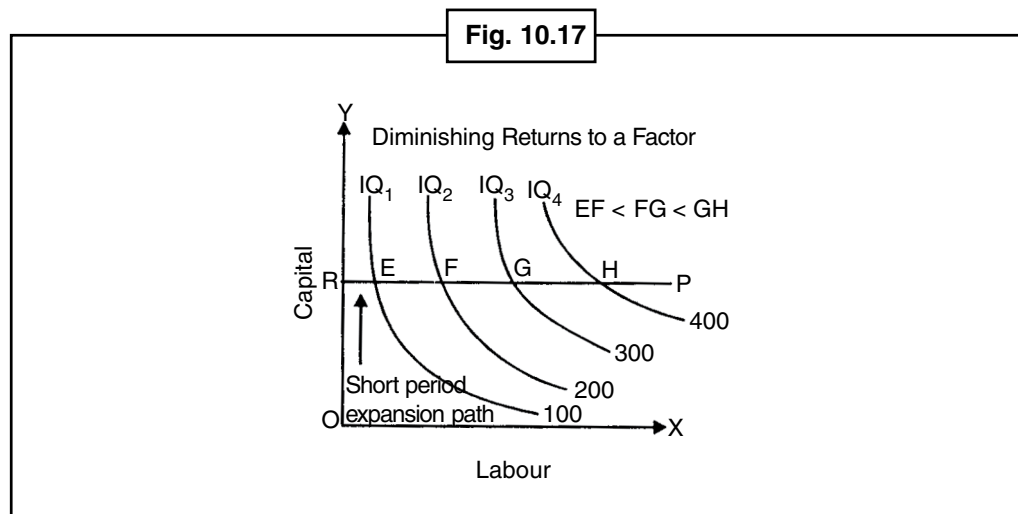

**Task** Give your opinion on Expansion Path.

It means that to increase 100 units of production can occur by increasing labour alternatively. The extra 100 units of production between E and F can be obtained by using 10 extra units of labour. The extra 100 units of production between F and G can be obtained by using 20 extra units of labour. The production path RP shows that when labour increases then the marginal production of labour decreases.

3. **Constant Returns to a Factor:** Constant Returns to a Factor is the situation where the total production increases in constant rate by using extra units of variable factors. Figure 10.18 shows constant returns to a factor. When capital is stable in OR and production is increased by using extra units of labour

**Notes**

then the differences between iso-production curves are equal, so to get 10 extra units of production, similar quantity of labour is required. It means that the marginal production of labour is stable. The differences between various iso-production curves are equal. It means,

$$EF = FG = GH$$

**Fig. 10.18**

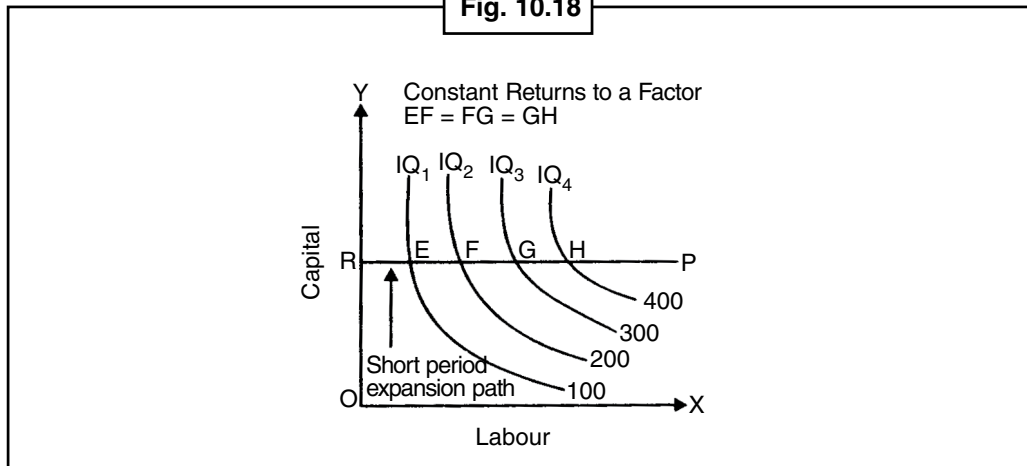

It shows that 100 units of production can be increased by using similar number of extra units of labour.

### 10.15 Summary

- **The downward slope of an iso-production curve is due to substitution of factors.** The factors of production are substitutes of each other. So to produce similar quantity of production, if one factor is used in low quantity then another can be used in high quantity. Due to this, the slope of iso-production curve is downward.

### 10.16 Keywords

- **Substitute:** Options
- **Producer:** Person who produce
- **Iso product:** Similar production
- **Principle:** Law

### 10.17 Review Questions

1. What is Isoquant curve? Explain it.
2. What do you mean by iso-cost line?
3. What is substitutional theory? Describe it.
4. What is Production Path? Describe it.

**Answers: Self Assessment**

Notes

- |           |             |          |          |
|-----------|-------------|----------|----------|
| 1. Reveal | 2. Marginal | 3. Law   | 4. (a)   |
| 5. (c)    | 6. (a)      | 7. (a)   | 8. (a)   |
| 9. True   | 10. True    | 11. True | 12. True |

**10.18 Further Readings**

Books

1. **Microeconomics**—*Robert S. Predik, Daniel L. Rubinfeld and Prem L. Mehta, Pearson Education, 2009, PBK, 7th Edition.*
2. **Microeconomics**—*David Basenco and Ronald Bruetigame, Wiley India, 2011, PBK, 4th Edition.*
3. **Microeconomics**—*Shipra Mukhopadhyay, Annie Books, 2011.*

## Unit-11: Concepts of Revenue

### CONTENTS

Objectives

Introduction

- 11.1 What is Revenue?
- 11.2 Concepts of Revenue Under Different Market Conditions
- 11.3 Concepts of Revenue Under Perfect Competitions
- 11.4 Concepts of Revenue Under Monopoly and Monopolistic Competitions
- 11.5 Rectangular Hyperbola AR Curve Under Monopoly
- 11.6 Graphical or Geometrical Relation between Total Average and Marginal Revenues
- 11.7 Mutual Determination of Elasticity of Demand, Average and Marginal Revenue
- 11.8 Total Revenue and Elasticity of Demand
- 11.9 Summary
- 11.10 Keywords
- 11.11 Review Questions
- 11.12 Further Readings

### Objectives

After studying this unit, students will be able to:

- Know Revenue.
- Understand the Concepts of Revenue Under Different Market Conditions.
- Explain Mutual Determination of Elasticity of Demand, Average and Marginal Revenue.
- Know Rectangular Hyperbola AR curve under Monopoly.

### Introduction

In monopoly condition, average revenue curve and marginal revenue curve are the downwards lines. It means that in various points of average revenue curves, the demand of elasticity is different. The relation between average revenue and marginal revenue can be known by demand of elasticity. It must be understood that average revenue of a firm is actually its demand curve. By this **firm knows that the price of product will change in which direction.**

## 11.1 What is Revenue?

Suppose that you have a factory to make ice cream. You made 1000 ice creams daily. You have earned ₹ 1,000 by selling these ice creams. In economics, this ₹ 1,000 is called your income. Thus, by selling a product whatever a firm earns, is the **revenue** of that firm. According to **Dooley**, “**The revenue of a firm is its sales, receipts or income.**” To know your total income, we just need to multiply the selling quantity of ice cream into the cost of ice cream. We can assume total demand from market demand table. The three assumptions of income are as follows:

### Total Revenue

Total revenue is called the money which is earned by a firm after selling a fixed quantity of product.

For example, if on ₹ 5 a product has sold its 6 units, then total income is ₹ 5 × 6 = ₹ 30. To get total revenue, either we can multiply the average revenue with selling quantity or add all the marginal units. Means

$$TR = P \times Q \text{ or } TR = \sum MR$$

(Here TR = Total Revenue; P = Price; Q = Quantity;  $\Sigma$  = Sign of Summation; MR = Marginal Revenue)

### Average Revenue

Average Revenue is the term which is nothing but price per unit. Means the price of product and average revenue are same. It means the average revenue is defined as per unit revenue of product.

According to **McConnell**, “Average revenue is the per unit revenue received from the sale of one unit of commodity.” Average revenue is the ratio of total revenue from selling quantity of product. The average revenue can be got by division of total selling quantity by total revenue.

$$AR = \frac{TR}{Q} = \frac{P \times Q}{Q} = P$$

(Here AR = Average Revenue; TR = Total Revenue; Q = Selling Quantity; P = Price)

So the **meaning of average revenue is price of product**. If we get ₹ 30 by selling 6 units of product then average revenue or price would be ₹ 30 ÷ 6 = ₹ 5.

### Marginal Revenue

Marginal revenue is nothing but the difference of total revenue of product by selling one more or one less product. According to **Ferguson**, “Marginal Revenue is the change in total revenue which results from the sale of one more or one less unit of output.”

—Ferguson

To know marginal revenue, either we can divide the change in total revenue ( $\Delta TR$ ) from change in product quantity ( $\Delta Q$ ) or by subtracting total revenue of  $n$  products from the total revenue of  $n - 1$  products.

$$MR = \frac{\text{Change in Total Revenue/Income}}{\text{Change in Quantity Sold}} = \frac{\Delta TR}{\Delta Q}$$

or  $MR = TR_n - TR_{n-1}$



**Notes**

(Here, MR = marginal amount;  $\Delta$  = change in; TR = total amount; Q = production or sales volume.  $TR_n = n$  the units total income;  $TR_{n-1} = n - 1$  the units total income,  $n$  is the number of units sold.)

For example, if 4 items are sold then total revenue is ₹ 28 and if 5 items are sold then total revenue is increased by ₹ 30. So the marginal revenue of fifth item would be ₹ 30 - ₹ 28 = ₹ 2. This can also be described as rate of change in total revenue.

*Revenue should not understood as profit. Revenue means the income of producer by selling his items. In contrast, profit is the difference between total revenue and total cost.*

## 11.2 Concepts of Revenue Under Different Market Conditions

The nature of concept of revenue depends upon the nature of those market competitions where the product is going to sell. Three market conditions are: (i) **Perfect Competition**; (ii) **Monopoly and (iii) Monopolistic Competition**.

## 11.3 Concepts of Revenue Under Perfect Competition

Perfect competition is the state of market where there are lots of sellers and buyers of a unique product and all sellers sell the product at a similar price. From Table 1 and Fig. 11.1, all 3 conceptions of revenue in perfect competitions are described, means (i) **Total Revenue**; (ii) **Average Revenue and (iii) Marginal Revenue**.

### Self Assessment

Fill in the blanks:

1. The revenue of a firm is its ..... income.
2. The per unit of income by selling a product is ..... .
3. The average revenue means a product has ..... .
4. When demand of elasticity is unit then marginal revenue is ..... .

Table 1: Different Concepts of Revenue under Perfect Competition			
Sold Quantity	Total Revenue (in ₹)	Average Revenue or Price (in ₹)	Marginal Revenue (in ₹)
Q	$TR = AR \times Q$	$AR \text{ or } P = \frac{TP}{Q}$	$MR = TR_n - TR_{n-1}$
1	5	5	5
2	10	5	5
3	15	5	5
4	20	5	5

- (i) **Total Revenue:** From Table 1, it indicates that the price of product is stable in perfect competition, so the total revenue increased at a stable rate. For example, on price ₹ 5, the total revenue of 2 units is ₹ 10 and for 3 units it is ₹ 15. The total revenue is increasing by ₹ 5 constantly by selling per extra unit.
- (ii) **Average Revenue:** Table 1 makes it clear that full competition changes to the amount sold along with the average price change proceeds or not. As per above table, it would be ₹ 5 either the firm sells one unit or 4 units. The reason behind this is in perfect competition, the price of product is determined by industry and firm can sell numerous quantity of that product.

(iii) **Marginal Revenue:** From Table 1 it is clear that the marginal revenue of firm in perfect competition is stable (means ₹ 5) even it sells as much as products. In fact, the price or average revenue is stable, so the marginal revenue is also stable because by selling per extra unit, the firm gets equal amount. So in perfect competition, average revenue and marginal revenue are always same ( $AR = MR$ ). To get marginal revenue, we can divide the changes happened with total revenue ( $\Delta TR$ ) by changes in sold quantity ( $\Delta Q$ ) i.e.,  $MR = \frac{\Delta TR}{\Delta Q}$ . From Table 1, it has been got that by selling 2nd unit, change in total revenue is ₹ 10 - ₹ 5 = ₹ 5 and the quantity of sold product has changed to 2 - 1 = 1 unit. So the marginal revenue is ₹  $\frac{5}{1}$ . Thus, the marginal revenue for the 3rd, 4th and other units would ₹ 5.

In Fig. 11.1 the conception of Total Revenue (TR), Average Revenue (AR) and Marginal Revenue (MR) has been described.

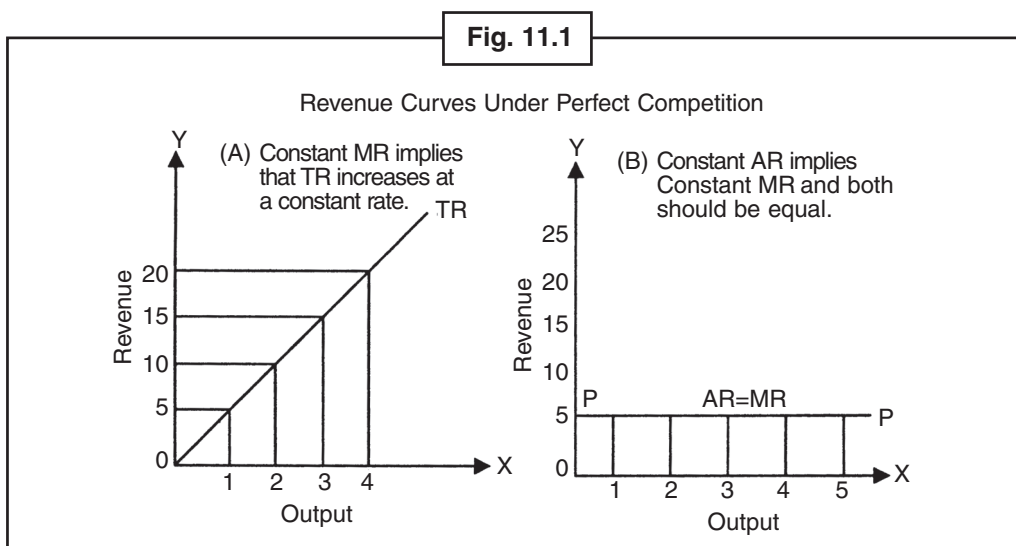

In Fig. 11.1 (A) and (B) revenue is on axis OY while output is on axis OX. In Fig. 11.1 (A), TR curve is total revenue curve. This is a straight line whose slope is upward. This proves that the total revenue is increasing at a constant level. In Fig. 11.1 (B), the vertical line PP which is parallel to axis OX represents both Average Revenue and Marginal Revenue. This indicates that AR is stable means equal to ₹ 5 and  $AR = MR$ .



**Notes** The marginal revenue is nothing but the difference between the total revenue by selling one more or one less unit.

## 11.4 Concepts of Revenue Under Monopoly and Monopolistic Competitions

The concept of revenue under monopoly and monopolistic competitions i.e. (i) Total Revenue, (ii) Average Revenue and (iii) Marginal Revenue are described by Table 2 and Fig. 11.2.

Notes

Table 2: Different Concepts of Revenue Under Monopoly/Monopolistic Competitions			
Sold Quantity $Q$	Total Revenue (in ₹) $TR = AR \times Q$	Average Revenue or Price (in ₹) $AR \text{ or } P = \frac{TR}{Q}$	Marginal Revenue (in ₹) $MR = TR_n - TR_{n-1}$
1	10	10	10
2	18	9	8
3	24	8	6
4	28	7	4

(i) **Total Revenue:** Table 2 indicates that in monopolistic condition, total revenue is increasing but at a decreasing rate. We have already learned that in perfect competition, a producer can sell any quantity of product by given price. So the total revenue increases at a stable rate. But in monopoly or monopolistic competition, the producer can only sell the product by its fewer price. So as soon as a product selling is increased, the price (AR) of it gets low. If price (AR) gets low then the marginal revenue (MR) also decreases. So, in monopoly or monopolistic competition, the total revenue (TR) increases at a decreasing rate.

*Decrease Marginal Revenue means Total Revenue is increasing but decrease rate. Decrease average revenue means the marginal revenue is decreasing by more than that it.*

In Fig. 11.2 (A), TR curve indicates total revenue. TR curve is expanding but at a decreasing rate. It means that as soon as the selling of product increases, the slope of TR curve decreases.

(ii) **Average Revenue:** Table 2, indicates that in monopoly or monopolistic competition, average revenue or price lessens if sale of that product is high. When monopoly sells one Q wheat then the price is ₹ 10, if sale is 2 Q, (quintal) the price drops by ₹ 9 and in 3 Q, it comes on ₹ 8. It means that the monopolist cannot control both quantity of selling and price of the product. He can sell more only by decreasing the price of product.

(iii) **Marginal Revenue:** Table 2 indicates that in monopoly or monopolistic competition, the marginal revenue gets down. When monopolistic sells is 2 Q then the marginal revenue is ₹ 8, the marginal revenue for 3rd Q is ₹ 6 and 4th Q is ₹ 4. The marginal revenue and average revenue (MR = AR) are equal in perfect competition. But in monopoly or monopolistic competition, marginal revenue and average revenue

*As MR decreases at a faster rate than AR, so MR curve is under the left side of the AR curve.*

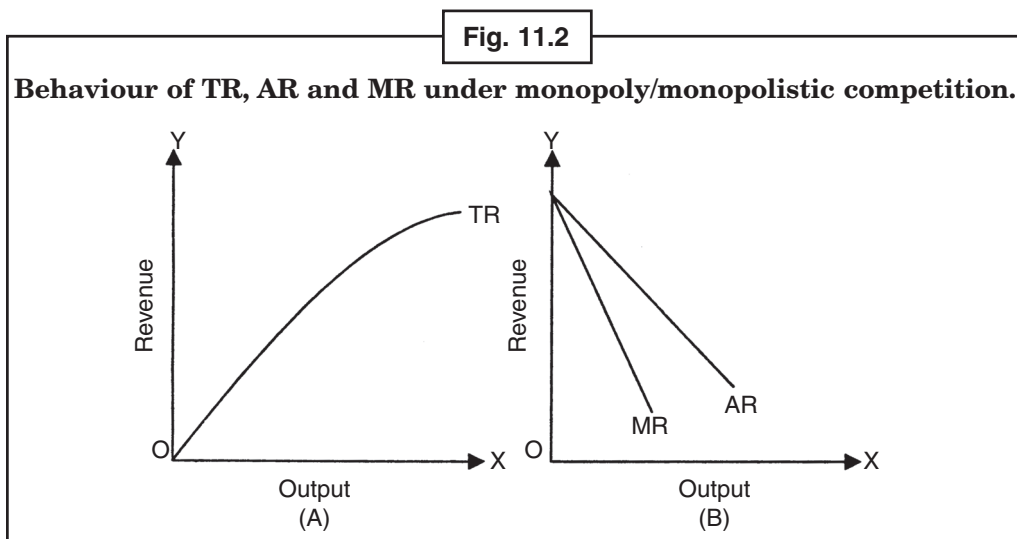

are different to each other. The marginal revenue is less than average revenue ( $MR < AR$ ). This is the reason that when average revenue is less then the marginal revenue also lessens and the marginal revenue gets smaller than average revenue.

In Fig. 11.2, the total revenue, average revenue and marginal revenue are shown in monopoly or monopolistic competition.

In Fig. 11.2 (B), average revenue Curve AR and marginal revenue curve are drawn. Both curves are separate and downwards. It means the monopolists need to decrease the product price to increase sell. Figure 11.2 (B) indicates that the CR Curve is below than AR Curve. This means that the decrement of marginal revenue is greater than average revenue.

#### Must remember

*The sloping of AR curve is always downwards in monopoly and monopolistic competition, but this is more flexible in monopoly competition. The reason behind this is in monopoly, there is no nearest substitute, while there is many substitutes for a product in monopolistic competition.*

### Self Assessment

#### Multiple choice questions:

5. Revenue should not understand as ..... .  
 (a) profit                      (b) loss                      (c) sell                      (d) buy
6. Revenue is ..... from a product to its producer.  
 (a) profit                      (b) loss                      (c) total price income      (d) capital
7. The difference in total revenue by a firm by selling more or less of one more unit, is called ..... .  
 (a) marginal revenue      (b) revenue                      (c) total revenue              (d) none of these
8. The decreasing of marginal revenue indicates that revenue is rising at a ..... .  
 (a) decreasing rate      (b) increasing rate              (c) marginal rate              (d) none of these

### 11.5 Rectangular Hyperbola AR Curve Under Monopoly

In monopoly condition, the income curve shows in Fig. 11.3, can be **rectangular hyperbola as shown in Fig. 11.3. In pure monopoly condition, the producer can so powerful that he sells all his products**

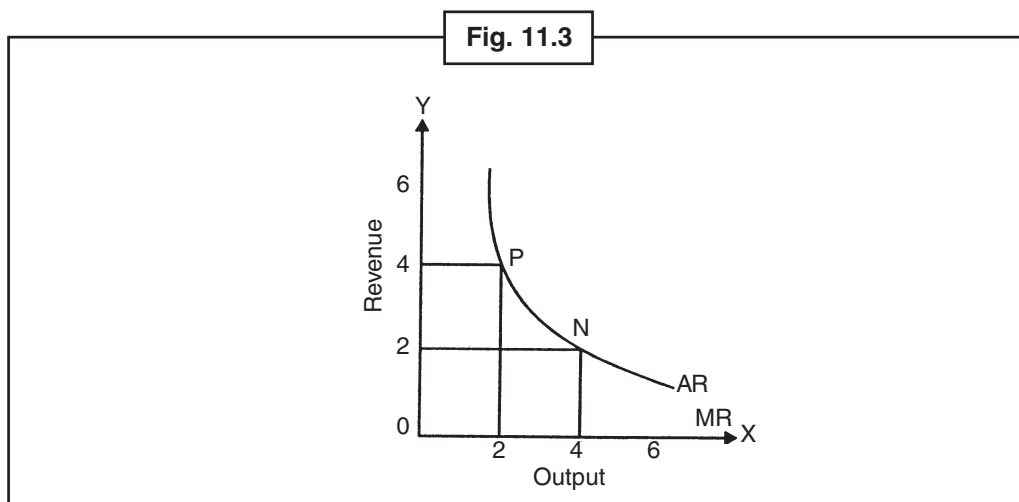

Notes

and gets all the income of customer. In this condition, the average revenue curve is a rectangular hyperbola. It means that the total revenue by selling the product would be same whether the monopolist decides any price of product. So all the points of AR curve are equal to each other in below region. So the marginal revenue line (MR curve) is indicated by axis OX. In Fig. 11.3, it is shown that AR curve is a **Rectangular Hyperbola**. Suppose that consumer has ₹ 8. When monopolist decides the price of product as ₹ 4, as shown by point P, two units of product have been sold means total income is ₹ 8. In contrast when monopoly lessens the price of product and makes it as ₹ 3, then point N shows that 4 units of products have been sold. So the total income would be ₹ 8. This also indicates that the marginal revenue for second product would be zero. In this figure OX-axis is MR Curve.

### 11.6 Graphical or Geometrical Relation between Total Average and Marginal Revenues

There is following relation of a firm's Total, Average and Marginal Revenues:

1. **When average revenue and marginal revenue curves coincide and are represented by a horizontal straight line parallel to OX axis:** Average and Marginal revenue are similar if average revenue curve and marginal revenue curve are similar then ( $AR = MR$ ). The reason behind this is firm can sell any quantity of product on the given price. Since average revenue is at a stable price so marginal revenue would also be stable and total revenue would increase by a constant rate.

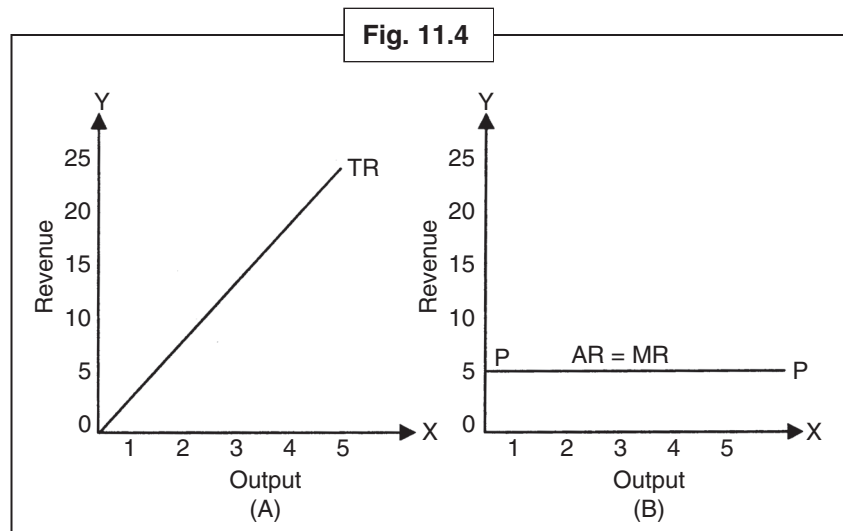

In Fig. 11.4 (A) and Fig. 11.4 (B), the total revenue of a firm, average and marginal revenue curve are shown. In Fig. 11.4 (A) it indicates that total revenue curve (TR) is upward straight line. The total revenue is increasing in similar pattern as per unit sold. By Fig. 11.4 (B) it is known that PP line indicates the average revenue and marginal revenue. This line is parallel to OX. This shows that average revenue and marginal revenue are same ( $AR = MR$ ).

2. **When average revenue and marginal revenue curves are straight line sloping downwards:** In Fig. 11.5 the average revenue curve and marginal revenue curve are downward straight lines. In this condition, marginal revenue curve would be in the middle of average revenue curve and line OY. It means that this condition happens in monopoly and monopolistic competitions. In this state,

$$AB = BC$$

Notes

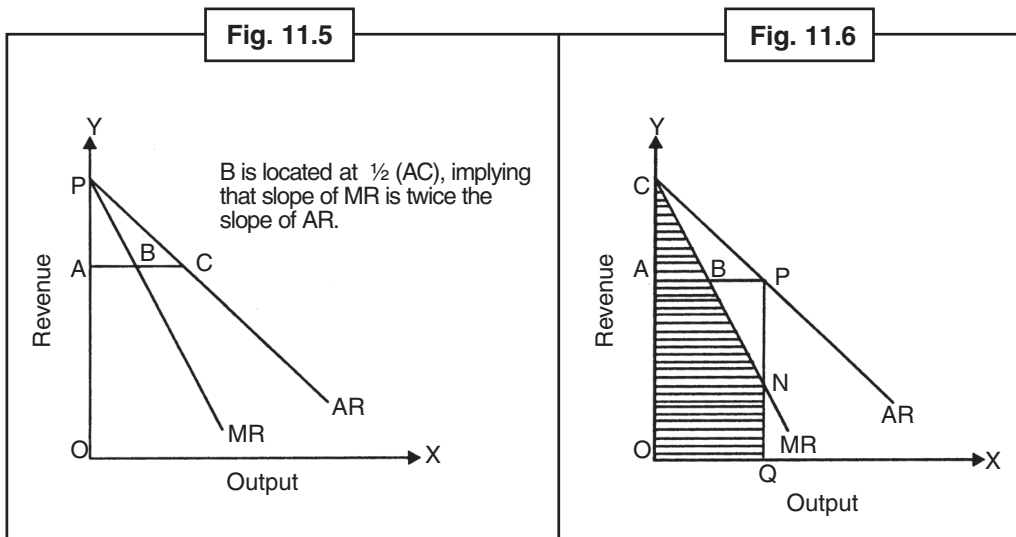

the relation between total revenue (TR), average revenue (AR) and marginal revenue (MR) can be identified by Fig. 11.6.

$$TR = AR \times Q = OA \times OQ (= AP) = OAPQ$$

or

$$TR = \sum MR = OCNQ$$

Therefore

$$\sum MR = AR \times Q$$

or

$$OCNQ = OAPQ$$

or

$$TR = AR \times Q = \sum MR$$

(Here, TR = Total Revenue; AR = Average Revenue; Q = Quantity of Product; MR = Marginal Revenue;  $\Sigma$  = sign of Summation)

*If AB = BP (see Fig. 10.6) so it can be removed easily to the conclusion that MR Curve slope is double.*

The area of triangle  $\Delta ACB$  and  $\Delta BPN$  is same because both have calculated by subtracting OA BNQ. In other words,

$$\Delta ACB = \Delta BPN$$

(Both the triangles are similar because the area of  $\Delta ACB$  = area of  $\Delta BPN$ )

$$\angle ABC = \angle PBN \text{ (Vertical Angle)}$$

$$\angle CAB = \angle BPN \text{ (Right Angle)}$$

$$\therefore AB = BP$$

### 3. Relation between total revenue, marginal revenue and average revenue curves if AR and MR curves are separate and falling downwards:

The relation between total revenue, average revenue and marginal revenue is clear by Table 3 and Fig. 11.7.

## Notes

Table 3: Different Concepts of Revenue			
Units	Total Revenue	Average Revenue	Marginal Revenue
1	10	10	10
2	18	9	8
3	24	8	6
4	28	7	4
5	30	6	2
6	30	5	0
7	28	4	-2

## Self Assessment

State whether the following statements are True/False:

9. When both average revenue and marginal revenue are falling then the marginal revenue is greater than average revenue.
10. The average of revenue is always positive.
11. Marginal revenue can be positive zero or negative.
12. When elasticity of demand is more than per unit then marginal revenue is positive.

From Table 3 we can know that the total revenue is increasing from the sixth unit of product. After that it has started increasing. As soon as more units of product are sold, the average revenue and marginal revenue get lower. Average revenue is always positive but marginal revenue can be positive, zero or negative. Table 3 shows that the marginal revenue for the sixth unit is zero and negative for seventh unit.

All the three concepts of revenue can be described by Fig. 11.7. In Fig. 11.7 (A) the total revenue curve and in 11.7 (B) average and marginal revenue curves are indicated. On the OX axis both (A) and (B), units of product have shown while revenue is displayed on OY axis. Fig. 11.7 (A) identifies that total revenue is increasing from point O to B. When the total revenue is maximum in point B then as per Fig. 11.7 (B), the marginal revenue is zero. After point B, the curve of total average falls. It means that however the product has been sold in large number but the total average decreases. In this condition, marginal revenue is negative. In Fig. 11.7 (B) it is shown that AR is average revenue curve. The slope of this curve is downward. It is proved that to sell more units, average revenue or price would be low. In Fig. 11.7 (B), MR is marginal revenue curve. The slope of this curve is also downward. It means that however the products are sold in greater quantity, but the marginal revenue would be low. The marginal revenue for sixth unit is zero and seventh unit is negative. We can see that when average revenue and marginal revenue are falling then marginal revenue is lower than average revenue.

- (i) It must be known that average revenue or price is represented by the slope of O and TR curve is represented by a straight line. For example, in Fig. 11.7 (A) the slope of line OA is  $PQ/PQ$  on the point P on TR line.
- (ii) Any slope of tangent line of any point of TR curve represents marginal revenue. For example, in Fig. 11.7 (A) the slope of tangent line TM represented as  $\frac{CE}{EF}$  marginal revenue on C point of TR.

Fig. 11.7

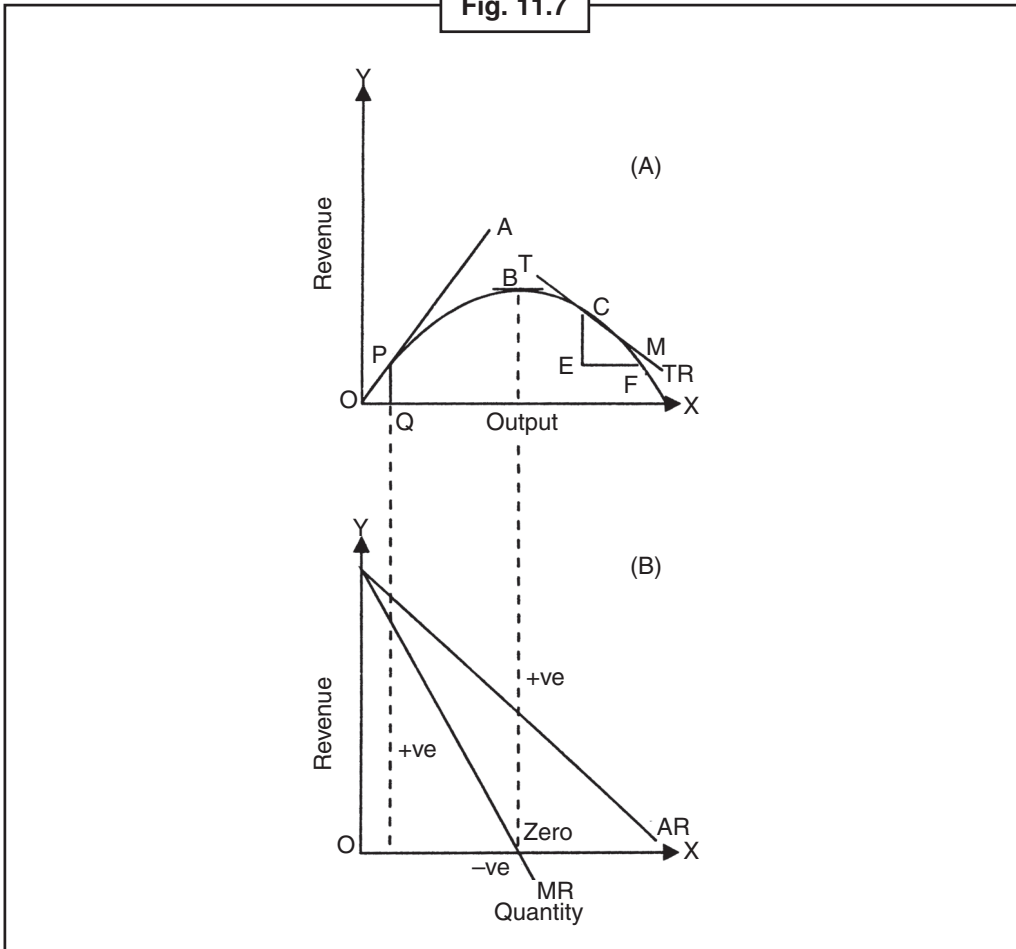

4. **When average revenue curve and marginal revenue curve are convex:** The average revenue curve and the marginal revenue curve represented in Fig. 11.8 are convex. In this stage, the marginal revenue curve intersects at some point to the vertical line put from any point in axis OY. It means that the marginal revenue curve is greater than average revenue curve in axis OY, i.e.  $AB < BC$  (AB is less than BC).

Fig. 11.8

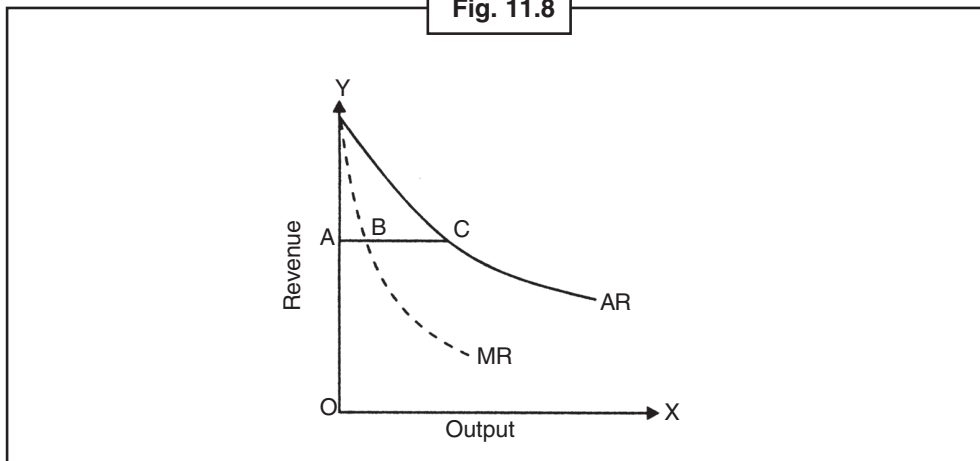



Notes

5. **When both average revenue and marginal revenue curve are concave:** The average revenue curve and marginal revenue curve are concave in Fig. 11.9. In this condition, the middle point on axis OY drawn from any point of average revenue curve intersects the curve of marginal revenue. It means that the marginal revenue curve will be far from axis OY. It means the marginal revenue curve will be nearer than average revenue curve. Means AB is greater than BC.

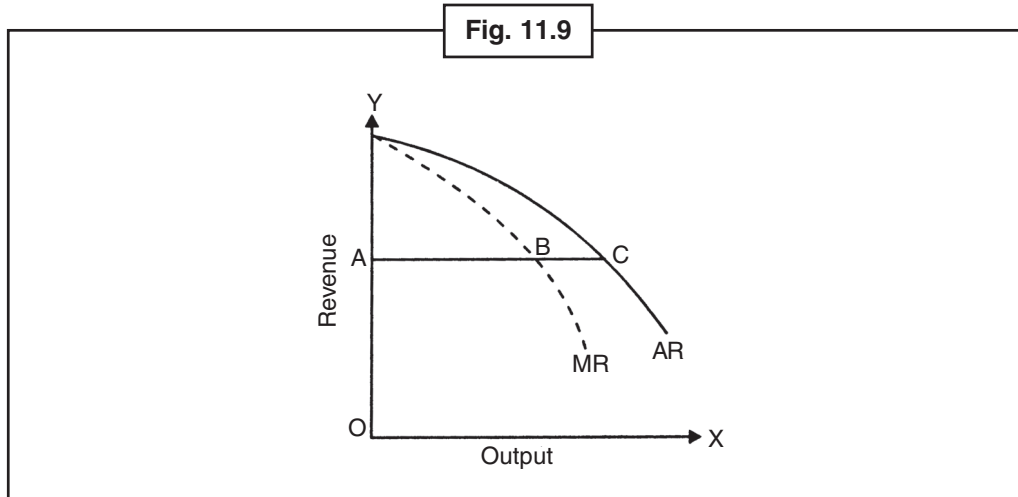

 *Did u know?* Per unit income by selling a product is called Average Revenue.

### 11.7 Mutual Determination of Elasticity of Demand, Average and Marginal Revenue

If any firm knows any two factors from average revenue, marginal revenue and elasticity of demand, then the third factor can be known by this equation –

$$e_d = \frac{AR}{AR - MR}$$

(Here  $e_d$  = Elasticity of demand; AR = Average Revenue; MR = Marginal Revenue)

In this elasticity of demand equation, the relations are defined by Fig. 11.10. This figure, shows that the elasticity of demand at point P is –

$$E = \frac{\text{Lower Portion}}{\text{Upper Portion}} = \frac{PB}{PQ}$$

$\Delta PMB$  is similar to triangle  $\Delta QRP$ . So the average of its line is equal.

$$\frac{PB}{PQ} = \frac{PM}{QR}$$

Cross a line from point P to OQ. Draw line QN from point P which intersects PR on its middle point S and OX to point N. Actually, this line is MR curve.

In  $\Delta PSA$  and  $\Delta QRS$

- PS = SR ..... (Construction)
- $\angle PSA = \angle QSR$  ..... (Vertically Opposite  $\angle S$ )
- $\angle QRS = \angle SPA$  ..... (Right  $\angle S$ )

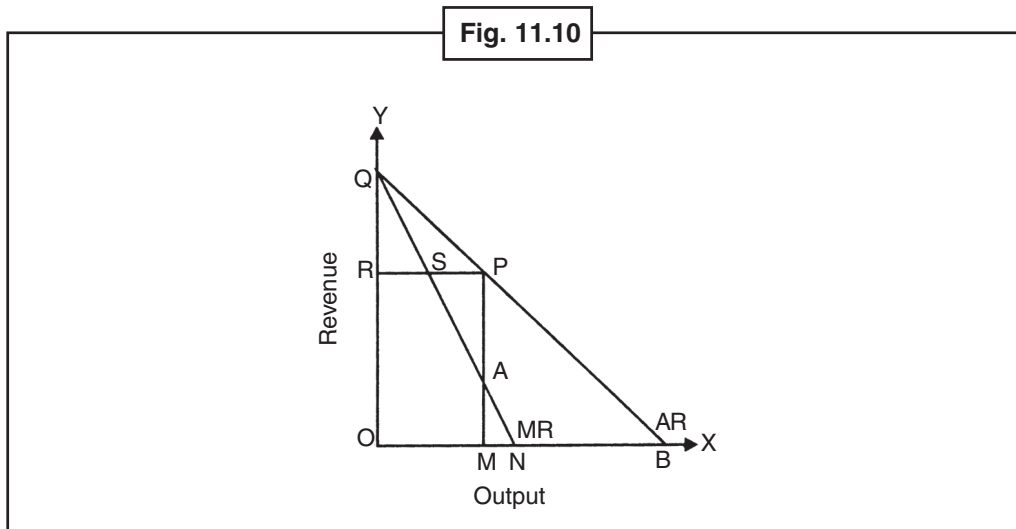

$\Delta PSA$  and  $\Delta QRS$  are congruent.

$$PA = QR$$

$$e_d = \frac{PB}{PQ} = \frac{PM}{OQ} = \frac{PM}{PA} \text{ (since } QR = PA \text{)}$$

or,

$$e_d = \frac{PM}{PA} = \frac{PM}{PM - AM} \text{ (since } PA = PM - AM \text{)}$$

(Here  $PM = AR$  or average revenue;  $AM = MR$  or marginal revenue and  $e_d =$  Elasticity of Demand), So it is proved that –

$$e_d = \frac{AR}{AR - MR}$$

If we know the formula given in two of the three elements, then we can find the third element.

$$e_d = \frac{AR}{AR - MR}$$

or,

$$e_d (AR - MR) = AR$$

or,

$$(e_d \times AR) - (AR) = e_d \times MR$$

or,

$$AR \times (e_d - 1) = e_d \times MR$$

or,

$$MR = \frac{(e_d - 1) \times AR}{e_d}$$

or,

$$AR = \frac{e_d \times MR}{(e_d - 1)}$$

So,

$$\text{Elasticity of Demand} = \frac{\text{Average Revenue}}{\text{Average Revenue} - \text{Marginal Revenue}}$$

$$\text{or } e_d = \frac{AR}{AR - MR}$$

$$\text{Average Revenue} = \frac{\text{Elasticity of Demand} \times \text{Marginal Revenue}}{\text{Elasticity of Demand} - 1}$$

$$\text{or } AR = \frac{e_d \times MR}{(e_d - 1)}$$

$$\text{Marginal Revenue} = \frac{\text{Average Revenue} (\text{Elasticity of Demand} - 1)}{\text{Elasticity of Demand}}$$

$$\text{or } MR = \frac{AR (e_d - 1)}{e_d}$$

Notes



*Task* Give your opinion on income or revenue income.

### 11.8 Total Revenue and Elasticity of Demand

The total revenue curve and marginal revenue curve are downward in monopoly condition. It means that the elasticity of demand is different in various points of average revenue curve. The relation between average revenue and marginal revenue can be identified by elasticity of demand. It must be known that the average revenue curve is demand curve for a firm. By this a **firm knows that the price of production will change in which direction**. The relation between Average Revenue (AR) and Marginal Revenue (MR) can be explained by elasticity of demand in Fig. 11.11.

In Fig. 11.11, AR is average revenue curve and MR is marginal revenue curve. It reveals that the elasticity of demand is greater ( $E > 1$ ) than average revenue curve on the left side of point M. So, the marginal curve would be **positive**. It means if the firm decreases the price of product then the total income would increase. So when marginal revenue is positive means the average revenue is greater than elasticity of demand then the firm should determine less cost to product. The average revenue curve is equal to elasticity of demand ( $E = 1$ ) at point M. In this condition, the marginal revenue would be **zero**. So if in this situation, a firm changes its price then the total revenue would not change. In this condition, there is no profit if firm changes the price of product. The average revenue curve is less than elasticity of demand ( $E < 1$ ) at point M. In this case marginal revenue is **negative**. So the firm will get profit if it increases the price of product. In other words, we can say that, (1) The marginal revenue can be positive, negative or zero but the average revenue will always be **positive**. (2) When marginal revenue is positive then the average revenue is greater than marginal revenue but when marginal revenue gets negative then average revenue gets lesser.

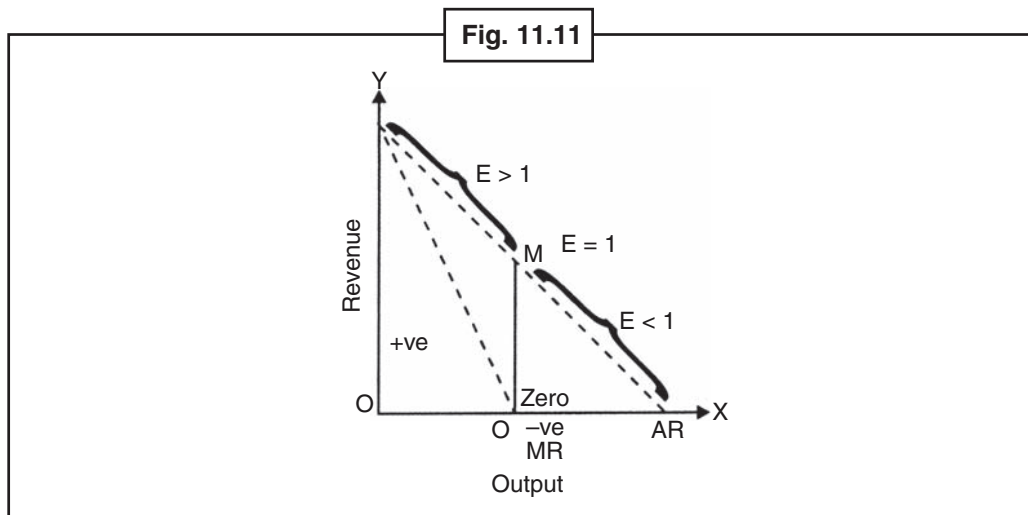

The relation between average revenue, marginal revenue and elasticity of demand can be as follows:

- (i) **When the elasticity of demand is infinity (a horizontal demand curve), marginal revenue is equal to average revenue.**

We know that—

$$MR = AR \left( \frac{e_d - 1}{e_d} \right) = AR \left( 1 - \frac{1}{e_d} \right)$$

To use the elasticity of demand (which is infinity) in this equation -

$$MR = AR = \left(1 - \frac{1}{\infty}\right) AR \text{ (1-0) AR or Price}$$

(ii) When elasticity of demand is unitary, marginal revenue is zero.

$$\begin{aligned} MR &= AR \left(\frac{e_d - 1}{e_d}\right) AR = AR \left(1 - \frac{1}{e_d}\right) \\ &= AR \left(1 - \frac{1}{1}\right) = AR \times (0) = 0 \end{aligned}$$

(iii) When elasticity of demand is greater than unitary (elastic demand) marginal revenue is positive. (MR > 0)

For example, when  $e_d = 3$ ; The marginal revenue (MR) is two - third of average revenue (AR).

$$MR = AR \left(1 - \frac{1}{e_d}\right) = AR \left(1 - \frac{1}{3}\right) = AR \left(\frac{2}{3}\right) = \frac{2}{3} AR$$

(iv) When elasticity of demand is less than unitary (inelastic demand), marginal revenue is negative. (MR < 0)

For example, when  $E = \frac{1}{2}$  and  $AR = 3$ , MR is positive.

$$\begin{aligned} MR &= AR \left(1 - \frac{1}{e_d}\right) = 3 \left(1 - \frac{1}{2}\right) = 3 (1 - 2) = 3 (-1) = -3 \\ MR &= -3 \end{aligned}$$

## 11.9 Summary

- In general language, average revenue is nothing but per unit cost. So the meaning of product price and average revenue is same. It means the average revenue is described as unit revenue of product.

## 11.10 Keywords

- **Revenue:** Total annual income of state.
- **Average Revenue:** Average income
- **Marginal Revenue:** Total income

## 11.11 Review Questions

1. What is income or revenue?
2. Define the concept of revenue in perfect competition.
3. What do you mean by elasticity of product demand?
4. Describe total revenue and elasticity of demand.

### Answers: Self Assessment

- |            |                    |          |          |
|------------|--------------------|----------|----------|
| 1. Selling | 2. Average Revenue | 3. Price | 4. Zero  |
| 5. (a)     | 6. (c)             | 7. (a)   | 8. (a)   |
| 9. False   | 10. True           | 11. True | 12. True |

Notes

## 11.12 Further Readings



*Books*

1. **Microeconomics: An Advanced Treatise**—*S. P. S. Chauhan, PHI Learning.*
2. **Microeconomics: Behaviour, Institutions and Evolutions** —*Sampool Bowels, Oxford University Press, 2004.*
3. **Microeconomics: Principles, Applications and Tools**—*Sanjay Basotiya, DND Publications, 2010.*

## Unit-12: Pricing Under Perfect Competition

### CONTENTS

Objectives

Introduction

- 12.1 Equilibrium Price
- 12.2 Importance of Time Element in Price Theory
- 12.3 Comparison between Market Price and Normal Price
- 12.4 Summary
- 12.5 Keywords
- 12.6 Review Questions
- 12.7 Further Readings

### Objectives

After studying this unit, students will be able to:

- Know equilibrium price.
- Understand importance of time factor in price theory.
- Compare between market price and normal price.

### Introduction

After studying the concepts of income proceeds, we will discuss pricing under perfect competition in the present unit.

### 12.1 Equilibrium Price

Two parties are dealing in the market – a buyer and a seller. Only after agreement between these two parties, a product is sold and purchased at a definite price. Thus buyers and sellers i.e., demand and supply have their impact on price determination.

Law of demand applies on buyers according to which price rise leads to decrease in demand and reduction in price leads to increase in demand. Law of supply applies towards supply according to which rise in price leads increase in supply and reduction in price of the product leads to decrease

**Notes**

in supply. So demand and supply are two opposing forces which move opposite to each other. Where they are equal, price is determined and that price is known as equilibrium price. At this price, quantity purchased and sold is known as equilibrium quantity. When the price is less or more than the equilibrium price, then equilibrium production deviates which finally settles equilibrium price. This process of price determination is evident in Table 1 and Fig.12.1.

The following table depicts schedule of demand and supply of apples when the price is ₹ 10 per kg. Then demand of apples is 120 kg and supply is 20 kg.

Table 1: Demand Supply Schedule		
Price in rupees	Quantity Demanded	Quantity Supplied
10	120	20
20	100	30
30	80	45
<b>Equilibrium Price → 40</b>	60	<b>60 ← 0 Equilibrium Quantity</b>
50	40	80
60	20	120

Rise in price leads to decrease in demand and increase in supply. When the price is ₹ 40 per kg, then both demand and supply are 60 kg. This is equilibrium quantity, which determines equilibrium price is ₹ 40 kg. Once equilibrium price is fixed, it has no tendency to change. If at any time, price becomes more or less than ₹ 40 then forces of demand and supply will bring it again on ₹ 40. For example, if price reduces from being ₹ 40 to 30, then demand will increase to 80 kg and supply will decrease to 45 kg. More demand for small quantity of apples will increase competition in buyers leading to rise in price to ₹ 40. This will result in decrease in demand to 60 kg and supply will increase to 60 kg. So equilibrium price is established again. In contrast when price will be ₹ 50, then demand will be 40 kg and supply will be ₹ 80 then every seller tries to sell his product first, so he reduces the price and others also follow till the price becomes ₹ 40 and equilibrium between the demand and supply is again established.

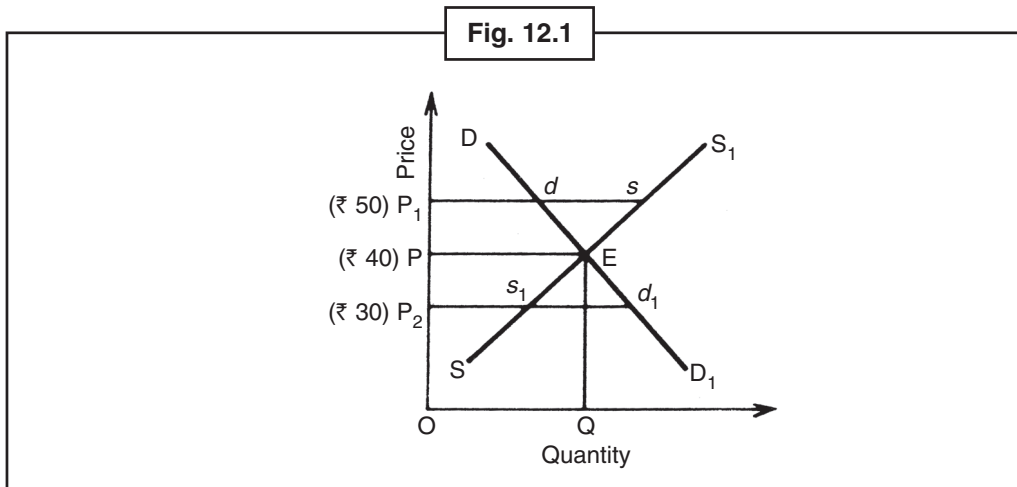

Figure 12 .1 depicts equilibrium price and production, where  $DD_1$  is demand curve and  $SS_1$  is supply curve. Both intersect at point E, which is the equilibrium point. OP is equilibrium price at which equilibrium quantity OQ is sold and purchased. If price reduces from OP to  $OP_2$  then demand increases from  $P_2d_1 >$  supply  $P_2s_1$  which increases the demand of  $s_1d_1$ . To increase the supply rather than demand creates competition among buyers leading to increase in price from  $OP_2$  to equilibrium price OP. If

price rises to OP from  $OP_1$  then (supply)  $P_1s > P_1d$  (demand), by which  $ds$  additional supply is created in market. On less demand, sellers decrease the prices to sell the additional supply, till equilibrium price is established again. This proves that price is determined by demand and supply and once equilibrium price is established, then in case of any deviation, forces of demand and supply will eventually brought the price to equilibrium point.

Notes



Notes Demand and supply are two opposite forces, which move opposite to each other.

## 12.2 Importance of time Element in Price Theory

**Marshall** was the first economist who analyzed the time element in price determination. When there is increase or decrease in the demand, then the increase or decrease in supply does not take place at the same time. Change in supply depends on the technical factors which take time to change that is why adjustment of supply with demand does not take place at once. How long will be the time period, depends as the fact that whether it is possible to bring change in scale of production, size and organization according to demands. Then there is also importance of time element in price determination as per nature of the goods price determination of perishable goods has more importance in small time period whereas long period is more important for durable commodities. In price determination **Marshall** has divided the equilibrium in demand and supply in four time periods—Market Period, Short Period, Long Period and Secular Period.

Now we discuss these time periods one by one:

**1. Market Period Price:** Market period is a very short period in which supply of goods being fixed, price is determined by demand. This time period lasts for some days or weeks in which supply can be increased as per demand with the available stocks only. It is possible for durable goods. Time period for perishable goods is one day. For instance, demand of vegetable if increases then they cannot be increased, that is why supply of vegetables being constant, price is determined by demand.

The price in the market period is known as market price which changes many times in a day, every day, many times a week or after the week according to nature of the goods. **Marshall** has described Market price as, “Market price normally gets affected by those incidents or reasons which are unstable. Its action is sudden in short run in comparison to those which move steadily.” Actually, market price is that price of a commodity which is determined by **interaction** of demand and supply at a definite time. Market price is determined differently for perishable and durable goods.

**Perishable Commodities:** Price of perishable goods such as milk, vegetables, fish, etc. is mainly influenced by demand. These are not affected by supply because their supply is fixed. So, increase in demand of perishable goods leads to rise in prices and decrease in demand results in fall in prices. In Fig. 12.2 price determination of perishable goods. Such as fish is explained. MS is supply curve which shows OQ is fixed quantity in market period. D is original demand curve which intersects supply curve MS at point E which results in determination of price OP. If demand increases from D To  $SD_1$  then the new equilibrium will be at  $E_1$  which shows rising price  $OP_1$ . On the other hand decrease in demand from D to  $D_2$  results in fall in price from OP to  $OP_2$ . This clarifies that market price is determined by demand only where supply OQ remains fixed. Every time demand of perishable goods like vegetable, milk, fish, ice etc. increases or decreases in summer, price will also rise or fall accordingly.



Notes

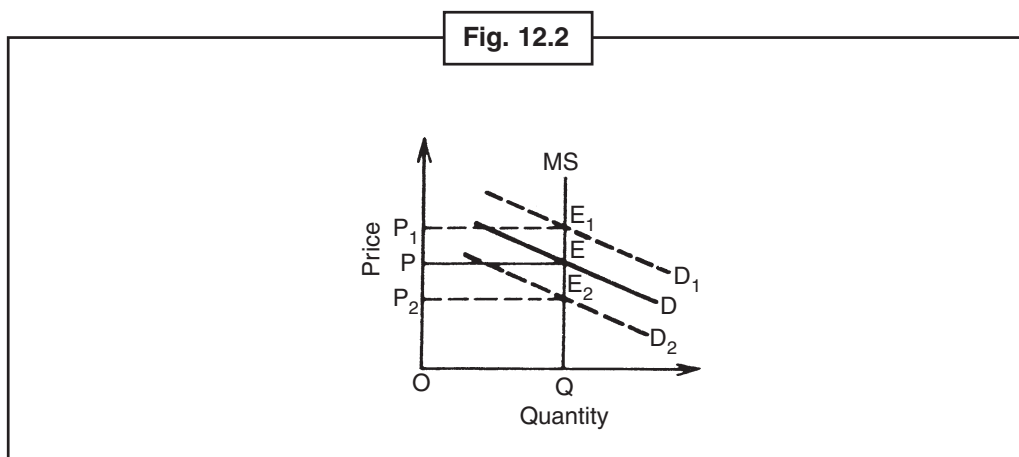

*Did u know?* Price in market is known as market price.

**Durable Commodities:** Many durable goods which are stored in stock and with the increase in demand when price rises then there can be increased to certain limit from the available stock. These are goods like cloth, wheat, tea etc .These types of goods have two price levels –

**One**, minimum price below which seller will not sell his products at any cost. It is known as **Reserve Price**. **Second**, maximum price at which the seller is ready to sell the entire quantity of his commodity.

**Self Assessment**

**Fill in the blanks:**

1. There are two parties dealing in the market. One buyer and the other .....
2. .... law applies on buyers.
3. Demand and supply are two opposite forces, which move ..... to each other.
4. **Marshall** was the first economist who ..... time element in price theory

Every seller considers these facts while putting a certain reserve price of his product –

- (i) **Durability of the commodity:** Reserve price depends on the durability of the commodity. The more durable the commodity is the more will be the reserve price.
- (ii) **Prices in future:** Reserve price depends on the changes in price in future. If there is hope of increase in prices then the seller fixes higher prices and if there is possibility of fall in prices then they fix low price.
- (iii) **Future cost of production:** Reserve price depends on future cost of production. If sellers hope to raise the cost in future, they will fix high reserve prices.
- (iv) **Expenses on storage:** Reprices are also determined by expenses and time on storage. As much cost includes investing in storage and time, the reserve price would high and vice versa.
- (v) **Liquidity Preference:** Reserve price depends on liquidity preference of the sellers. The more is the preference for cash, the lower will be the reserve price as due to more necessity of the N,

the seller will try to sell the goods as soon as possible. On the contrary, less cash preference will result in high reserve price.

- (vi) **Demand in future:** Reserve price depends on the demand in future. If the seller hopes that demand will rise in future, then he will fix high reserve price and possibility of less demand result in low reserve price.

So in this way, due to two price levels, sellers will not sell any quantity in minimum reserve price whereas at maximum price level he will be ready to sell the entire quantity of the product. As the price of the product will increase with the increase in demand, the seller will sell more quantity from the available stock till the demand reaches the maximum price at which he will sell the entire stock. After this, increase in supply will not be possible with the increase in demand. That is why the supply curve of durable goods is vertical at this level.

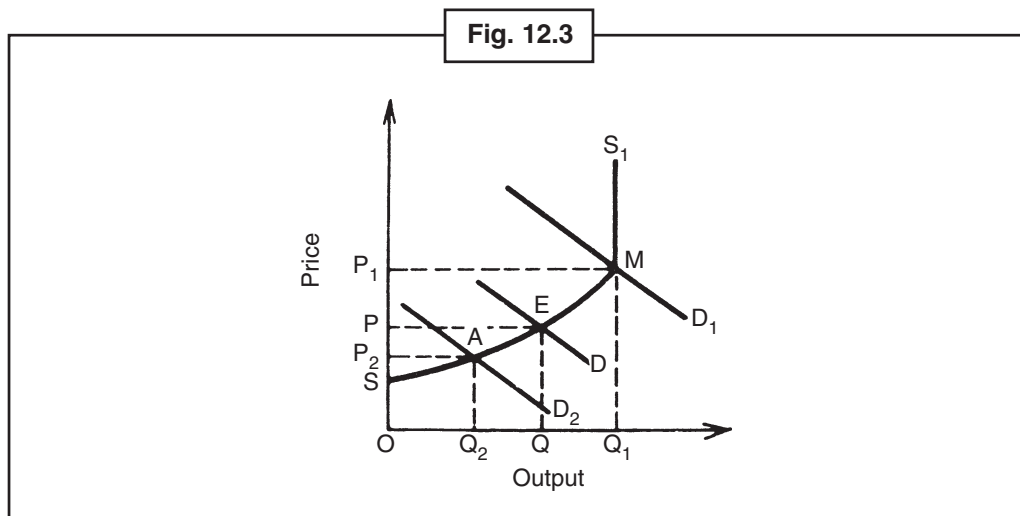

In Fig. 12.3.  $SMS_1$  is supply curve of market period.  $OQ_1$  is the total stock of the goods.  $OS$  is lowest or reserve price at which the seller does not sell the product at all. When demand curve  $D$  intersects supply curve  $SMS_1$  at  $E$ , then price  $OP$  is determined at which  $OQ$  quantity of the goods is sold and  $OQ_1$  remains in the stock of the seller. Decrease in the demand to  $D_2$  will result in fall in the prices from  $OP$  to  $OP_2$  at which  $OQ_2$  is sold and quantity  $Q_2Q_1$  is stored in the stock. The seller will be eager to sell the entire stored quantity at the maximum price  $OP_1$  only when the demand will rise to  $D_1$ . If demand further rises from  $D_1$  then price will increase again further because in market period, quantity more than  $OQ_1$  cannot be sold.

Thus in market period demand has more influence on price determination in comparison to supply because in very short run period sellers do not estimate production.

### Self Assessment

#### Multiple choice questions:

5. Reserve price depends on ..... of the product.
  - (a) durability      (b) buy      (c) sell      (d) price
6. Reserve price depends on ..... in future.
  - (a) cast      (b) cost of production      (c) productions      (d) time

**Notes**

7. Fall in cash preference results in reserve price being
  - (a) less
  - (b) more
  - (c) unreserved
  - (d) none of these
8. If seller hopes that costs will increase in future, then they will fix reserve price .....
  - (a) less
  - (b) very high
  - (c) high
  - (d) none of these

**2. Short period price:** Short period is a time some months in which supply can be changed in accordance with demand. It is possible by bringing change in variable factors. For instance, supply is to be increased then firm, by using labour, raw materials etc., in fixed factors present machinery, plant etc., can increase production by increasing work shift. In short run, it is not possible to bring change in scale of production, organization, and fixed factors, so increase and decrease in supply as per demand brought by increasing or decreasing quantities of variable factors.

In short period, price is determined by forces of demand and supply. Short period curve also slopes upwards from left to right like normal supply curve. When demand increases or decreases then equilibrium with supply curve determines short period prices which is also known as short run normal price. Figure 12.4 shows short run equilibrium price, determination D is the original demand curve and MS is supply curve of market period. Its equilibrium is established at point P where at PQ price quantity OQ of the product is sold or purchased, suppose demand of clothes is increased, which is depicted by  $D_1$  curve. It results in increase in price from PQ to  $P'Q$ . In market period, supply being fixed cannot be increased more than OQ. Yes, by increasing employee, more labour, raw material etc. in present machinery and plants, supply can be increased in short period. In this way on increasing quantity of variable factors, increase in supply will correspond to supply curve SRS. Supply curve SRS intersect new demand curve  $D_1$ , at point  $P_1$ , and then short run price or short run normal price  $P_1Q_1$  is determined, at which quantity  $OQ_1$  is sold or purchased. This short period price ( $P_1Q_1$ ) is more than the original market price PQ but with the increase in demand, market price is less than  $P'Q$ .

Now suppose there is fall in demand of clothes. Demand curve will shift from D to  $D_2$ . Market price PQ will fall to  $P_2Q_2$ . In short period, all firms or an industry will employ less variable factors like labour, raw materials etc. and decrease the supply. So SRS curve will make equilibrium at point  $P_2$  on  $D_2$  as a result of which at price  $P_2Q_2$  less quantity  $OQ_2$  of the goods will be purchased or sold. But price  $P_2Q_2$  is less than the original market price PQ but is more than the later price  $P''Q$ . Thus, in short period, supply has some importance compared to demand because increase or decrease in supply can be brought as per demands, increasing or decreasing the variable factors.

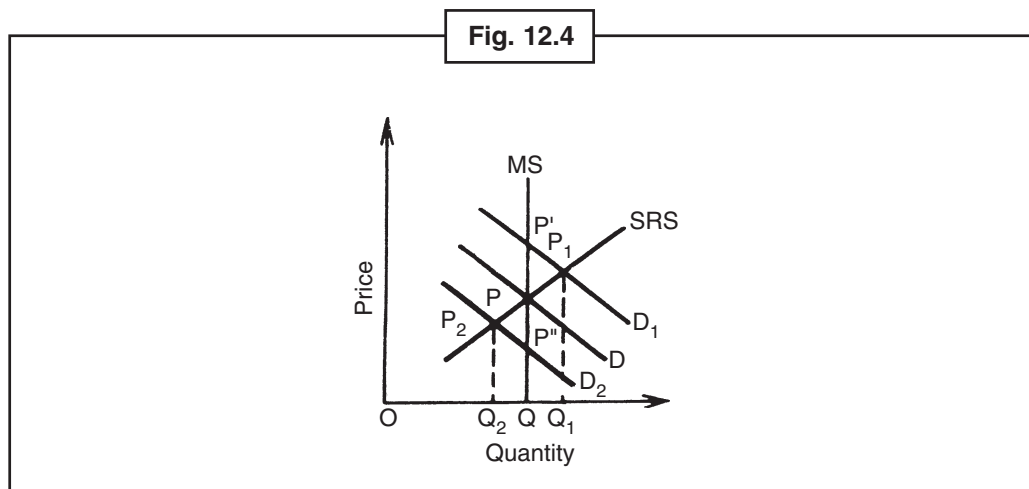

**3. Long period price or Normal Price:** Long period is of many years in which supply can be adjusted in accordance with demand. In the long run, supply can be changed corresponding to demand buying changes in the fixed factors. It is that time in which old machines, equipment, plants etc. can be replaced with the new machines, equipment etc. New firms can enter into the industry and old firms can leave the industry. Scale of production, organization and management of firms can be changed. So in long run, supply can be adjusted as per demand from every point of view.

Long run price is also known as normal price. Normal price is that price which has the possibility to exist in the long run, and which is fixed in the long run. In the words of **Marshall**, "**Normal or natural value is that which economic forces would tend to bring about in the long run.**" Actually, normal price is the price between very high price and very low price which has the possibility to exist in the long run. It is that price around which all other prices revolve.

Long run or normal price is determined by the equilibrium of demand and supply. In long run, it is necessary for firms and industry that normal price of the goods would be equal to marginal cost and average cost. If price would be higher than the minimum average cost then every firm will earn **Super Normal Profits** which will attract new firm to enter into the industry, then supply will increase and price will be reduced and will be equal to minimum average cost. On the other hand, firm will incur losses when prices will be less than the average costs. Some firms which could not incur the losses will leave the industry, then supply will be reduced and price will rise to be equal to average cost. Thus, long run price or normal price will always be equal to minimum average cost. This is clarified in Fig. 12.5 in which LAC and LMC are long run average cost and long run marginal cost. Long run equilibrium is at point E where  $LMC = MR = AR = LAC$  at minimum point. OP price is determined at which OQ quantity of the product is sold through firm.

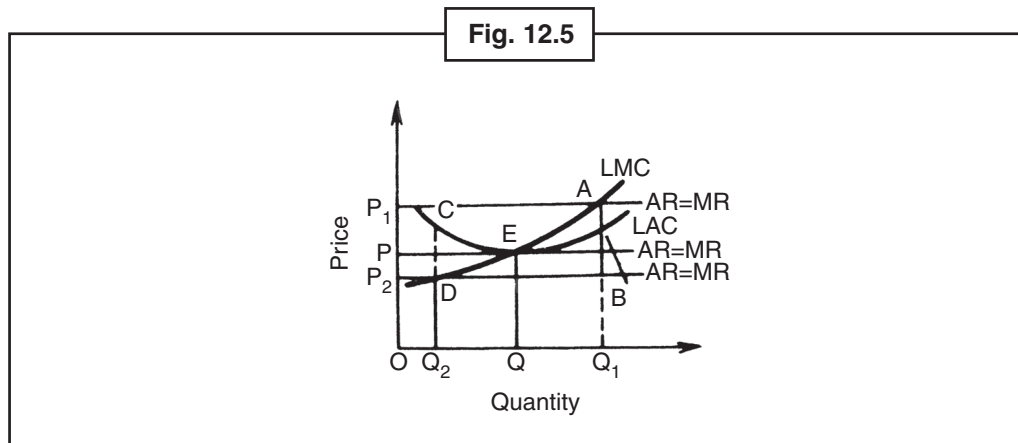

This is **normal price** that has tendency to be for long-time. If price rises from OP to  $OP_1$ , then firms will sell  $QQ_1$  quantity of goods more than before. From which they will have additional profit of AB amount per unit of goods. Getting attracted with this profit, new firm will enter into industry. Resulting in the increase in supply of goods and price will fall to OP where long time equilibrium will be set at point E. In opposite with the fall of price from OP to  $OP_2$ , the supply of goods decreases to  $Q_2Q$  and firms will undergo a loss of CD amount per unit of goods. If firms fail to maintain this loss then most of the firm will leave out industry. Due to this supply will decrease, price will rise and at least price will be OP where at point E long time equilibrium will be attained once again.



Task

Express your views on long time price or normal price.

**Notes**

**Long-Run Price and the Laws of Returns:** In the analysis of Long-Run Price, it is important to understand when this price will be more, less or equal to market price that means what affects laws of return put on long-run price. If industry produces according to the law of decreasing return or increasing cost, then long-run price will be more than original market price. When law of constant return or constant cost applies, then the long-run price will be equal to original market price, whereas on the application of law of increasing return or decreasing cost, long-run price will be less than original market price. Long-run price determination on increase in demand under various production laws is explained below with the help of Fig. 12.6.

When Law of Diminishing returns or increasing costs applies on industry, the long-time supply curve LRS slopes upward from left to right, as shown in Fig. 12.6. MS is market duration supply curve. SRS is short-duration supply curve. D is original demand curve, which intersects market-duration supply curve at point P, from which original market price PQ is determined and OQ amount of goods is sold or bought. With the increase of demand to  $D_1$ , market price rises to  $P'Q$ , due to volatile factors. Thus the price will fall from  $PQ$  to  $P_1Q$  when long duration due to increase of coordinates of production, organization etc. supply increases from  $OQ_1$  to  $OQ_2$ , and then the long run price  $P_2Q_2$  is determined. This price is more than original market price  $PQ$ , because the industry runs on the laws of increasing cost. According to which with the increase of supply, costs will also increase per unit.

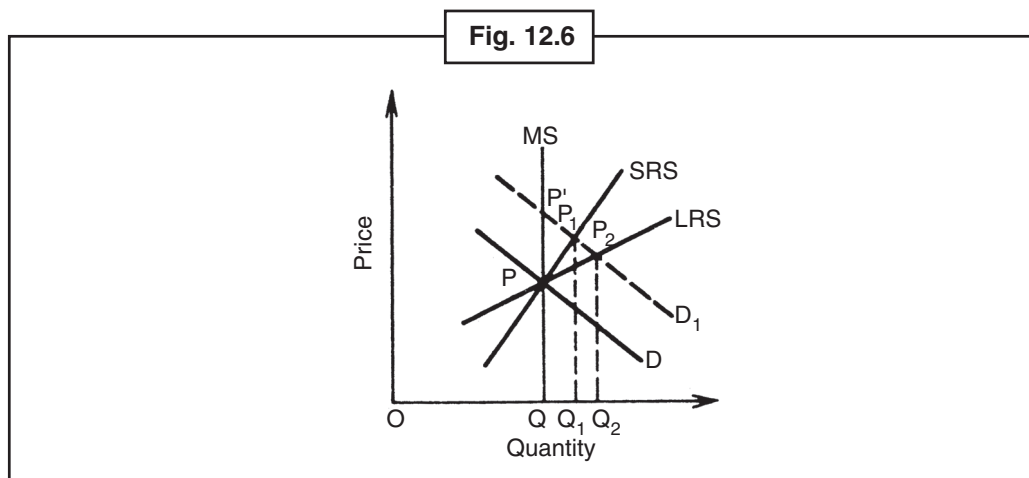

**Law of Constant Returns of Costs:** When the law of constant returns of costs applies, the long time supply curve LRS is supposed to be parallel to X-axis as shown in Fig. 12.7. When demand increases from D to  $D_1$ , then the market price rises from  $PQ$  to  $P'Q$ . When supply during short duration increases from  $OQ$  to  $OQ_1$  then the price falls from  $P'Q$  to  $P_1Q_1$ . When supply increases to  $OQ_2$  during long run then the prices fall to  $P_2Q_2$ . This price is equivalent to original market price ( $P_2Q_2 = PQ$ ). The reason is when the production is increased on the application of law of constant costs in an industry then the cost per unit remains constant.

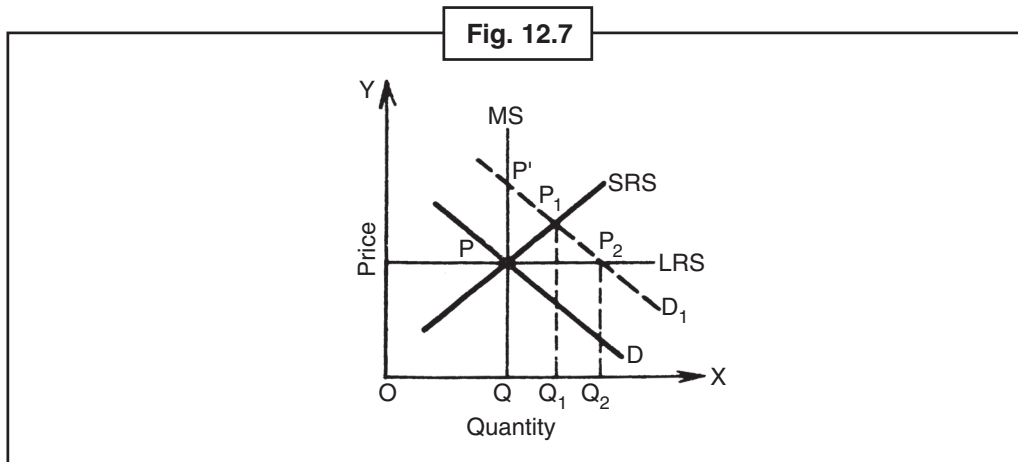

When the **law of increasing returns or diminishing costs** applies to an industry, then the long time supply curve slopes downward from left to right as LRS curve shown in Fig. 12.8. PQ is original market price and OQ quantity of goods is sold or purchased, then as demand increases from D to  $D_1$ , then market price rises to  $P'Q$  at once. With the increase of supply from OQ to  $OQ_1$ , during short time, then the price falls from  $P'Q$  to  $P_1Q_1$ . There long time price is less than original market price,  $P_2Q_2 < PQ$ . The reason is when production increases on implementing the laws of increasing returns to an industry, then the cost per units diminishes.

We come to this conclusion that the factor whether long time price will be more, equal or less than the original market price is dependent on the fact which law (Law of Diminishing Return, Law of Constant Return or Law of Increasing Return) is applicable to an industry.

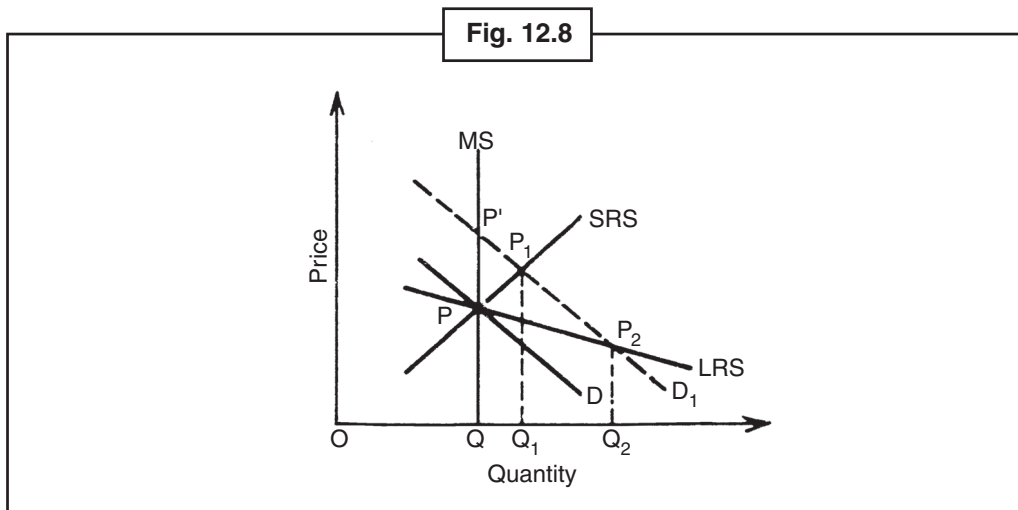

**4. Secular Period:** Secular period is of very long time. According to **Marshall** it is more than 10 years of time in which with the change in demand completely adjusted with the supply can be done. To understand the changes in technique, population, raw material and demand etc, during this long term is impossible that is why **Marshall** did not analyze the price determination during the secular period.

## Notes

**12.3 Comparison between Market Price and Normal Price**

Difference between market price and normal price are as follows –

- (1) Market price is that price which is found for one day or very less days. It is a very short run price which prevails in the market at a particular time. On the other hand, normal price is that price which tends to prevail in the long run.
- (2) In market price determination demand is active whereas supply is inactive. Market price falls or rises with the decrease or increase in demand where supply is fixed. In other hand, in the determination of normal price, supply is more active because it has the tendency to be in rhythm in accordance with change in demand in the long run.
- (3) Market price is influenced by temporary events. It is changed with change in events in a day or a week. Sudden rain in a very hot day can reduce the demand for ice and price as well this way, market price is temporary. On the other hand, normal price is the consequence of fixed factor which brings about change in demand and supply, change in consumer's interests, preferences, habits, etc. can result in change in demand whereas change is the fixed factors of production can result in the change of supply. Consequently, normal price is a permanent and fixed price. That is why, market price tends to move around normal price as is shown in Fig. 12.9, where NP is normal price and MP is market price.
- (4) Market price can be above or below the production cost. Thus, firms can earn abnormal profits or incur losses whereas; normal price is always to lowest point of LAC. That is why, under normal price, firms can only earn normal profit.

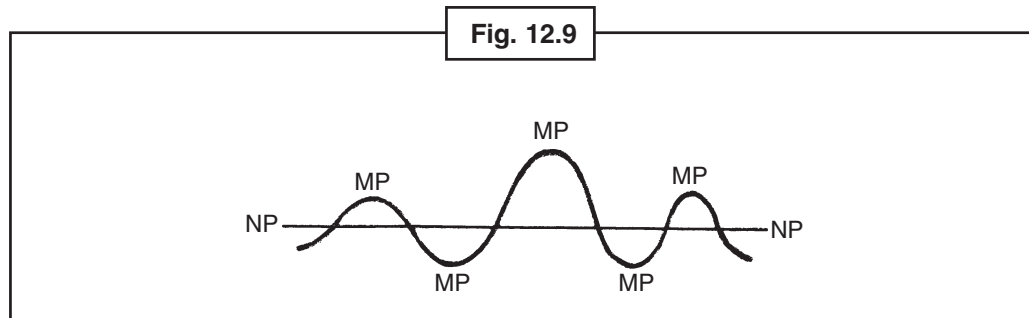
**Self Assessment**

State whether the following statements are True/False:

9. In short period, prices are determined by forces of demand and supply.
10. Long run or normal price determines the equilibrium of demand and supply.
11. Market price is that price which exists for day or very few days in the market.
12. In the determination of market price, demand remains active and supply inactive.
- (5) Every article, whether they can be reproduced or not, has market price. But reproduced products will only have normal price. If any product cannot be recreated then its supply cannot be increased in the long run, when its demand will rise. For instance, any painting by Tagore lies at shopkeeper, then he cannot charge normal price because Tagore is not alive, so similar painting cannot be created. This painting can be sold only on market price which depends on its demand at a particular time.
- (6) Market price is a real price that exists in the market at a particular time. On the other hand, normal price is an unreal price. It is shapeless and illusionary, which is unrealistic. It is like mirage. A small

wave of the sea is real but quiet water of the sea at the horizon is an illusion which is like mirage which is never quiet. These small waves of the sea are like market price whereas quiet water of the horizon is like normal price. As **Stonier** and **Hague** have described, "In practical, normal price will never come in long run. There will be normally some changes in the conditions of long run equilibrium, before it is reached. Like tomorrow, long run never comes." And the price prevails in the market is always market price, not normal price.

## 12.4 Summary

- It is concluded with the above discussion that importance of time element in price theory is that which force between demand and supply is more powerful in price determination, depends on the time period. Normally, the shorter the time period, the more is the influence of demand on the price determination and the longer the time period the more is the influence of supply on the price determination.

## 12.5 Keywords

- **Vertical:** Standing straight.
- **Perishable Commodities:** Subject to decay Products.
- **Durable Commodities:** Safe products.
- **Secular Period:** Related to long time.

## 12.6 Review Questions

1. What is meant by equilibrium price? Explain.
2. Explain the importance of time element in price theory.
3. Differentiate between Market Price and Normal Price.
4. Which factors are considered by a seller to fix reserve price of his product?

### Answers: Self Assessment

- |           |           |             |             |
|-----------|-----------|-------------|-------------|
| 1. Vendor | 2. Demand | 3. Opposite | 4. Analysis |
| 5. (c)    | 6. (b)    | 7. (b)      | 8. (c)      |
| 9. True   | 10. False | 11. True    | 12. True.   |

## 12.7 Further Readings



Books

1. **Microeconomics**—*Frank Cowbell, Oxford University Press, 2007.*
2. **Microeconomics**—*Robert S. Predik, Daniel L. Robinfield and Prem L. Mehta, Pearson Education, 2009, PBK, 7th Edition.*
3. **Microeconomics**—*David Bosanko and Ronald Brutigame, Wiley India, 2011, PBK, 4th Edition.*



## Unit-13: Theory of Monopoly Firm

### CONTENTS

Objectives

Introduction

- 13.1 What is Monopoly?
- 13.2 Features of Monopoly
- 13.3 Monopoly Equilibrium or Determination of Price and Output Under Monopoly
- 13.4 Total Revenue and Total Cost Curve Approach
- 13.5 Marginal Revenue and Marginal Cost Approach
- 13.6 Price Discrimination or Discriminating Monopoly
- 13.7 Types of Price Discrimination
- 13.8 Degrees of Price Discrimination
- 13.9 Essential Conditions for Price Discrimination
- 13.10 When Price Discrimination is Profitable
- 13.11 Price and Output Determination Under Discriminating Monopoly
- 13.12 Dumping
- 13.13 Price and Output Determination Under Dumping
- 13.14 Monopoly Price with Zero Cost of Production
- 13.15 Is Monopoly Price Always Higher than the Perfectly Competitive Price?
- 13.16 Multi-plant Monopoly
- 13.17 Allocative Inefficiency of Monopoly/Dead Weight Loss
- 13.18 Supply Curve of a Firm Under Monopoly
- 13.19 Summary
- 13.20 Keywords
- 13.21 Review Questions
- 13.22 Further Readings

## Objectives

After studying this unit, students will be able to:

- Study the Monopoly.
- Know the types of Discrimination.
- Understand the Jumping.
- Study the multi-plant Monopoly.

## Introduction

In monopoly, there should only one producer of goods whether it may be single or group of partners, or joint capital company or state. So in the state of monopoly, there only be a firm, but the numbers of buyers must be enough that buyer will not be able to affect the price of goods but suppliers do so.

### 13.1 What is Monopoly?

The English word Monopoly has been taken from Greek word Monopolion. It means sole proprietorship of selling. **So pure monopoly is that state of market in which only one firm is the sole producer of particular goods, and there is no close substitute of those goods.** As the monopolist is the only supplier of goods in market, that is why neither there is any competitor nor any visible opponent.

#### **What is Pure Monopoly?**

*It is that type of market where there is only one supplier who has complete control on the price of goods.*

For example, electricity in your home or factory can be drawn only through electricity board. You can travel by only Indian Government Railway. These are all examples of monopoly. In the state of monopoly no other firm can enter into industry. There is no difference between firm and industry. Firm itself is an industry because it is the only producer of goods in market. Monopolist is the **Price Maker**, he determines the price. It depends on the price determined by him that how much quantity of goods he will sell. The demand curve of monopoly slopes from top to downward.

According to **Koutsoyiannis**, "Monopoly is a market situation in which there is a single seller, there are no close substitutes for commodity it produces, there are barriers to entry."

– **Koutsoyiannis**

In the words of **Baumol**, "A pure monopoly is defined as the firm that is also an industry. It is the only supplier of some particular commodities for which there exists no close substitutes."

– **Baumol**

### 13.2 Features of Monopoly

Main features of Monopoly are given below:

1. **One seller and Larger Number of Buyers:** In monopoly, there should be single producer of commodity whether it is single, or group of partners, or joint capital company or state. Hence in the situation of monopoly there is only one firm but the number of buyers should be enough. As a result the price of goods would not be affected by buyer but by the seller.
2. **Monopoly is also an Industry:** In the situation of monopoly there is only one firm, hence the difference between firm and industry finishes, that means there is no difference in the study of monopoly firm or industry.

**Notes**

3. **Restrictions on the Entry of the New Firms:** In the field of monopoly, there are restrictions for new firm to enter into the market. These restrictions have many forms like Patent proprietorship, government laws, savings of coordinate etc.
4. **No Close Substitutes:** For goods that are being produced by monopolist should not have any close substitutes otherwise monopolist will not be able to control the price of goods he produces, according to his wish. According to **Boulding**, "A pure monopoly firm is that firm which is producing such a product whose production by other firms outcomes no effective substitute."
5. **Price Maker:** Monopolist determines the price, which means he himself determines the price of his product. This is because he is the only supplier of goods but the number of buyers being very large. The demand of single buyer is very small portion of total demand, that is why buyer would not be able to affect the price, and they have to borne the price determined by monopolist. In other words price of goods is totally controlled by monopolist. If monopolist increases the supply of goods then their price may fall. Opposite to it if he decreases the supply, the price may rise.
6. **Price Discrimination:** Monopolist for any goods could charge differently to different buyers and for different purposes. In this way price discrimination is done by monopolies.
7. **Absence of Supply Curve:** In the situation of monopoly there is no supply curve. Taking both marginal revenue and marginal cost into consideration, he decides how much quantity to be produced and what price to be charged. So in monopoly no supply curve exists.

**Monopolist is Price Maker.**

*Yes monopolist is price maker. Price of goods is totally controlled by monopolist. The reason is –*

- *Monopolist is the only supplier, whereas it has large number of buyer.*
- *There is no close subtitle of the goods that monopolist produces.*
- *There are so many legal, practical and technical to restrictions on the entry of new firm.*

**Self Assessment**

**Fill in the blanks:**

1. Monopolist is the ..... maker.
2. English word monopoly has been taken from Greek word .....
3. Slope of demand curve in monopoly is from top to .....
4. Monopoly is that market where for any goods there is only one .....

**13.3 Monopoly Equilibrium or Determination of Price and Output Under Monopoly**

Monopolist is said to be at the state of equilibrium, where he produces that much amount of goods by which determination of price and equilibrium can be studied within following two approaches:

1. **Total Revenue and Total cost curve Approach.**
2. **Marginal Revenue and Marginal cost Approach.**



*Notes*

Monopoly is that situation of market where only one firm is the sole producer of goods. There is no close substitutes of those goods.

### 13.4 Total Revenue and Total Cost Curve Approach

Monopolist can achieve maximum profit by selling that particular quantity of goods at which the difference between total revenue and total cost would be maximum. A monopolist by projecting different prices of any goods or by altering the supply of goods, tries to understand that at which level of output the difference between total revenue (TR) and total cost (TC) would be maximum, or total profit would be maximum. **At that quantity of output producing which monopolist will get the maximum profit, monopolist will be at equilibrium.** It can be explained with the help of Fig. 13.1.

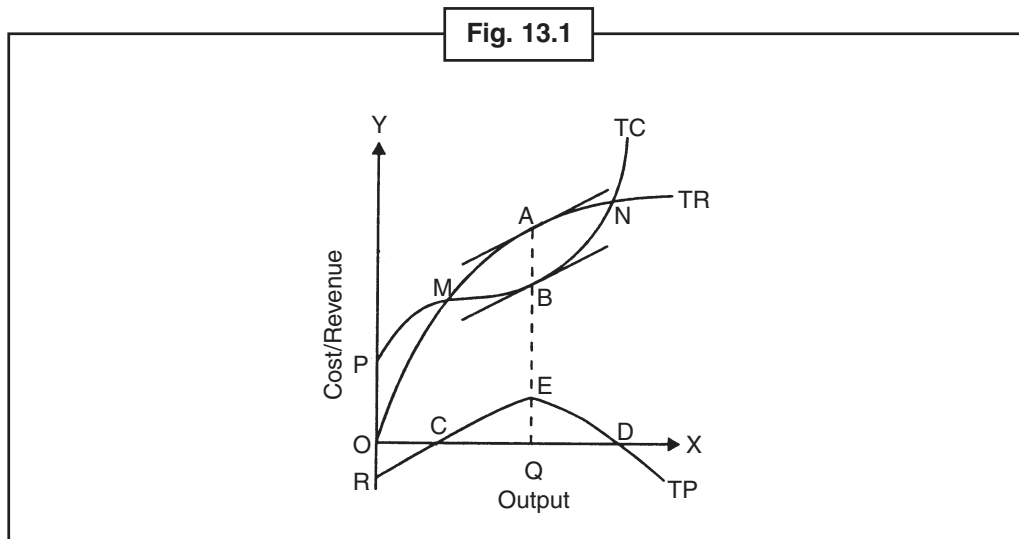

In Fig. 13.1, TC represents total cost curve while TR represents total revenue curve. TR curve is starting at origin point O, which means when there is not output total revenue will also be zero. In opposite total cost curve is starting at point P. The reason behind this if firm will stop production even then, it has to borne the tied up cost OP. TP curve is total profit curve. This curve is starting at point R. By this we knew that initially firm is getting **Negative Profits** means firm is in loss because total cost is more than total income. Figure 13.1 we learn that as the firm increases its output, the total income gets increased. But in initial stage total revenue is less than total costs ( $TR < TC$ ). It is understood by RC portion of TP curve that firm is in loss. At point M,  $TR = TC$ , so as it is clear with point C of TP curve that firm is gaining profit nor exhibiting loss. Point M will be called as Break Even point. When firm will produce more than point M then total revenue will increase than total cost, ( $TR > TC$ ). TP curve is also shifting upward from point C. This indicates that firm is gaining profit. When TP curve is at highest point E, then firm will gain maximum profit. Quantity of goods at which firm is getting its maximum profit will be known as equilibrium output.

**Please get conscious**

*In Fig. 13.1, TC curve starts from axis OY, so it should be low run cost curve. The high run TC cost curve starts from original point O.*

If firm will produce more than equilibrium quantity OQ, then the difference between TR and TC will go on decreasing, and these lines will intersect each other at point N, that is  $TR = TC$ . This means profit of firm will be decreasing and even at point N neither it will gain profit nor any loss. As it is described by point D of TP curve. If firm will produce more than this then TR will be less than TC. ( $TR < TC$ ), as a result firm will start losing. In brief, at point E firm will gain maximum profit. To know the maximum profit tangents are drawn to line TR and TC. At points where tangents are parallel, their distance will be maximum. As it is clear with this figure. tangents are parallel at points A and B, so maximum

**Notes**

difference of curve TR and TC will be specified with AB. At this state monopolist will gain maximum profit, as it is clear with point E of TP curve. This process of determining the price and equilibrium by monopolist is called Trial and Error method, because in this process by determining different price monopolist has to predict that at which level it will be at the state of equilibrium means will achieve maximum profit.

**Self Assessment**

**Multiple choice questions:**

5. In the situation of monopoly there is only one ..... .  
 (a) firm                      (b) currency                      (c) cost                      (d) commodity
6. In the field of monopoly for the entrance of new firm in market there is ..... .  
 (a) tax                      (b) restriction                      (c) prohibition                      (d) permission
7. In the situation of monopoly, there is no ..... curve.  
 (a) supply curve                      (b) cost curve                      (c) curve                      (d) supply curve
8. For the commodity during monopoly there is no ..... .  
 (a) close substitute                      (b) substitute                      (c) cost curve                      (d) none of these

**13.5 Marginal Revenue and Marginal Cost Approach**

According to this approach, equilibrium will be at place when following two conditions will be fulfilled –

- (i) **Marginal Revenue (MR) = Marginal cost (MC)** and
- (ii) Marginal Cost (MC) curve intersects to Marginal Revenue (MR) from below.

In this situation monopolist will gain maximum profit. By this analysis, the determination of price and equilibrium will be studied through two durations of time –

- (1) Short Run (2) Long Run

**Test Your Brain**

(See Fig. 13.1)

*When the difference between TR and TC is maximum then the slope of TR = slope of TC.*

*The slope of TR is MR and slope of TC is MC. So wherever the differences between TR and TC is maximum there is MR = MC.*

**Short Run equilibrium**

Short run is that duration of time in which time is so minute that monopoly cannot change tied up sources such as machinery and plant. Monopolist, with the rise of demand can increase supply by utilizing more quantity of variable sources and by utilizing the full capacity of tied up sources like machines. In the same way with the fall in demand monopolist will reduce the quantity of variable sources and also reduce the complete utilization of tied up sources. A monopolist will be at the state of equilibrium when it will produce that quantity of goods at which (1) **Marginal cost will be equal to Marginal revenue (MC = MR)** (2) **MC Curve cuts MR Curve from below**. During short run, there are three situations under the state of equilibrium for monopolist. Monopolist (1) May gain **Super Normal profits** (2) May achieve **Normal Profits** and (3) May have to bear **Minimum Loss**. These can be explained with the help of Figs. 13.2 - 13.4.

**(1) Super Normal Profits:** If under the situation of equilibrium the price of product (AR) determined by monopolist is more than their average costs (AC) ( $AR > AC$ ) then monopolist will gain **Super Normal Profits**. Monopolist will produce to the level where Marginal cost is equal to Marginal revenue

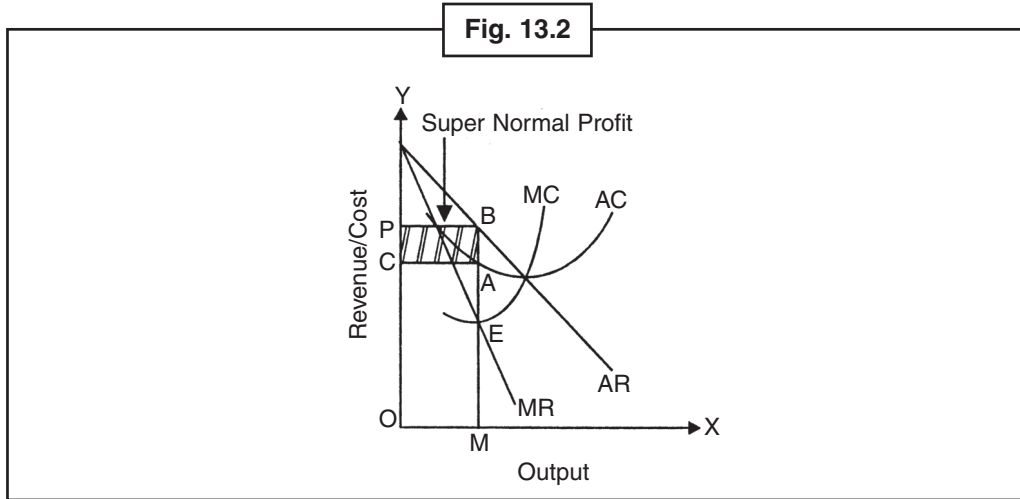

(MC = MR). It is called equilibrium production. If the price of equilibrium production is more than its average cost then monopolist will gain super normal profit.

$$\text{Super Normal Profit} = AR > AC$$

This situation of equilibrium can be explained with the help of Fig. 13.2. It shows monopolist will be at equilibrium at point E. Because at this point Marginal Revenue (MR) is equal to Marginal Cost (MC) means (MR=MC). Monopolist will produce the OM unit of goods. At this quantity of production price of goods (BM) will be more by BA amount to its average cost (AM) i.e. (BM-AM = BA). So in this situation monopolist will achieve total super normal profit of ABPC.

(2) **Normal Profits:** In the short run, in monopoly equilibrium state where MC = MR, price of the product (AR) is equal to (AC) Average cost then firm will earn only normal profits.

$$\text{Normal Profit} = AR = AC$$

This situation of monopoly equilibrium can be explained with the help of Fig. 13.3. The Fig. 13.3 indicates that monopolist will be at equilibrium at point E as at point E, MC = MR. Equilibrium

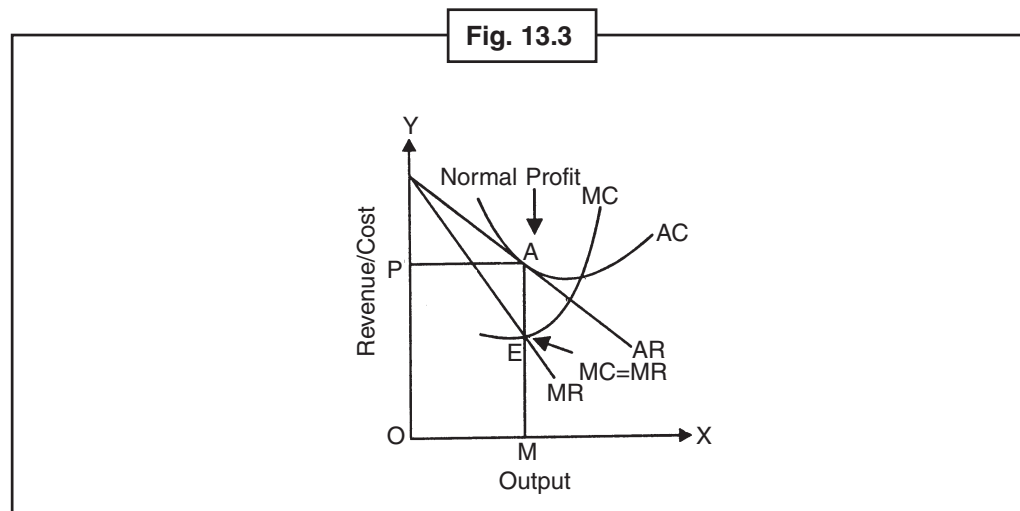

**Notes**

production of the monopolist is OM units. **Average Cost Curve (AC)** touches **Average Revenue Curve (AR)** at point A at this level production is at point A, Price OP (AR) of the product is equal to average cost AM (AC) so the monopolist will earn only **Normal Profits** at equilibrium production because at equilibrium quantity and average cost are equal to price (Average Income) ( $AC = AR$ ).

**(3) Minimum Loss:** In short run, demand of the goods decreases due to depression and as a result prices fall the monopolist will continue to produce at this reduced price if he is getting Average variable cost (AVC) at this price. If the monopolist will have to determine the prices less than the average variable cost then he will stop the production. Therefore, **the monopolist in the short run may have to bear minimum loss means can bear loss of average fixed cost**. In equilibrium situation prices (AR) of the product is equal to Average variable cost (AVC) so the monopolist may have to bear average fixed cost loss. This loss has to bear by monopolist even at the time when he stops work during short run. Therefore,

$$\text{Minimum Loss} = AC - AVC = AFC$$

This situation of equilibrium can be explained with the help of Fig. 13.4. Figure 13.4 shows monopolist is at equilibrium state at point E. Because at point E,  $MC = MR$ . By point E it is understood that monopolist will produce the OM quantity of goods. The price OP (AM) will be determined as the price for equilibrium quantity OM of goods. At this price, average variable curve (AVC) is touching AR curve at point A. It means firm will earn only average variable cost with this prevailing cost. Firm will have to bear fixed cost that means per unit AN loss. Firm will be in total loss of  $NAPP_1$ , as shown by shaded area. This will be lowest loss to firm. If monopolist will have to determine a price less than OP, then he will stop the production of goods.

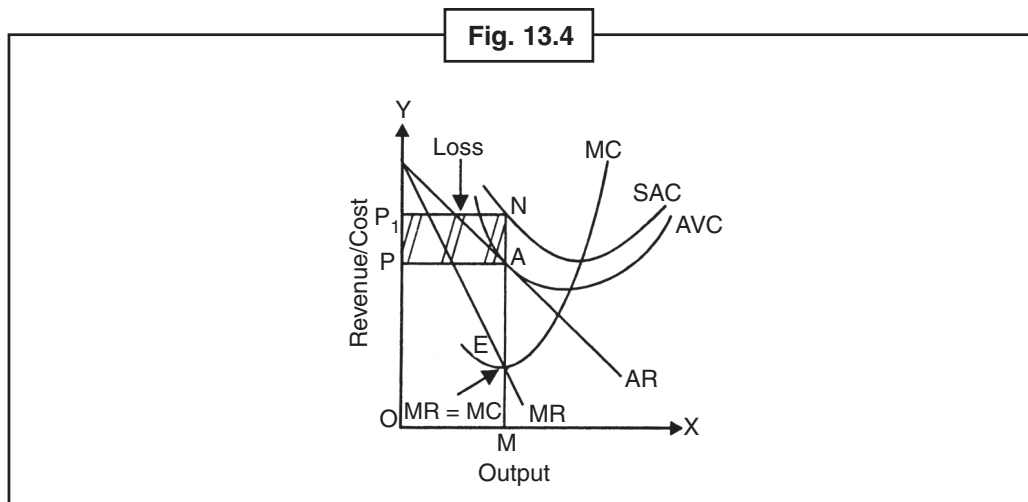

**Long-Run Equilibrium**

During Long Run, the monopolist will attain equilibrium at position where Long Run Marginal Cost will be equal to Marginal Revenue ( $LMC = MR$ ). Due to having long time during long run, monopolist can change all costs, and on the increase in demand supply to meet the demand can be adjusted in short-run price may be more, equal or less to this average costs. But in Long run price is more than long-run average costs. If price will be less than long-run average cost then monopolist will opt to stop production in place of bearing loss. During long run monopolist earns abnormal profit. This is because in opposite to complete competition, no firm can enter into market. So during long run when monopolists firm is earning abnormal profit, then no producer possibly with the intention of gaining abnormal profit can enter into market.

As a result, monopolist firm earns abnormal profit even at the time of long run. In opposite to complete competent firm, monopolist can earn abnormal profit during long run, because the entrance of new firm in market is restricted. Thus the monopoly firm gets abnormal profits in long run.

Unlike to full competitive firm a monopolist can earn abnormal profit in the long term because there is a ban on the entry to new firm into the market.

**In market monopolist, neither due to the entrance of any firm nor due to availability of any substitute is required to set up an optimum sized plant or to utilize optimum production capacity during long run. Size of plant or the utilization upto which extent of any particular size plant, is always dependent on the demand in market.** Under same market situation optimum capacity will be achieved but under some other situations monopolist will produce sub optimally. Under some different situations capacity more than optimum capacity can be utilized. It all depends on the demand in market. In Fig. 13.5, the maximum long run equilibrium has been explained, when size of market restricts monopolist to produce at minimum long-run average cost.

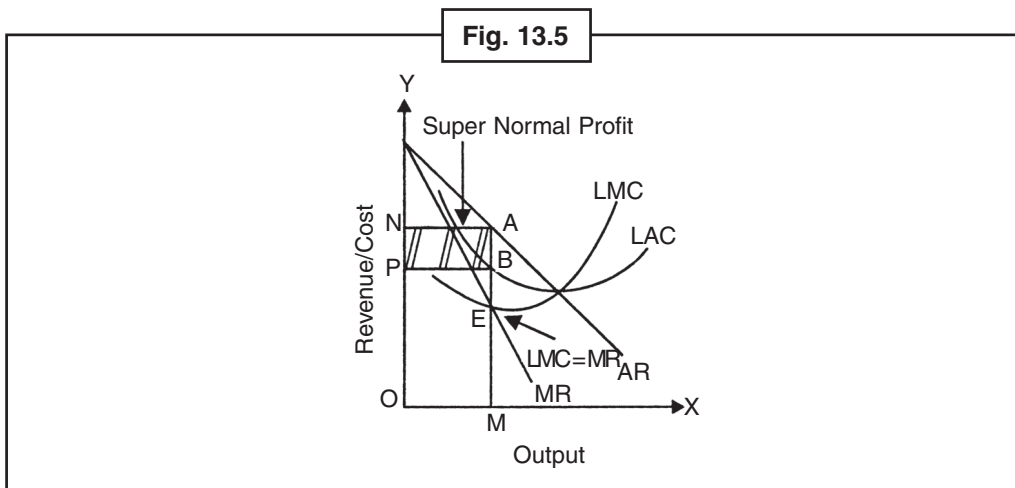

The situation of long run equilibrium of monopolist can be explained with the help of Fig. 13.5. Figure 13.5 shows that monopolist will be at equilibrium at point E. At point E,  $MR = LMC$ , he will produce  $OM$  quantity of product. This would be the equilibrium quantity. At this quantity, the price will  $ON (= AM)$  and long run average cost will be  $BM$ . As the price ( $AM$ ) is greater than long run average cost ( $BM$ ) i.e. ( $AR > AC$ ), monopolist will earn abnormal profit. Hence, monopolist will gain abnormal profit of  $AM - MB = AB$  per unit. Monopolist will gain a total of  $ABPN$ , as shown by shaded area.

### 13.6 Price Discrimination or Discriminating Monopoly

Price discrimination is that situation where goods are sold at more than one price. A monopolist can change differently for particular goods to different consumers and for different purpose this price strategy is called Price Discrimination, and the monopolist who does this is called Discriminating Monopolist. In the words of **J.S. Bains**, "Price Discrimination refers strictly to the practice by a seller to charge different prices from different buyers for the same product Q."

#### What is Price Discrimination?

Price discrimination is the situation where a supplier for a particular goods charge differently to different sellers. It is only possible when there is no competition in market and for different buyers the demand for goods is different.



**Notes** According to **Koutsoyiannis**, “Price discrimination exists when the same product is sold at different prices to different buyers.”

### 13.7 Types of Price Discrimination

Price Discrimination are mainly of four types –

1. **Personal Price Discrimination:** When particular goods are sold at different prices to different buyers then it is called personal price discrimination. Personal price discrimination is possible due to unawareness of customers, minor difference in price, or due to nature of goods or services. Like when a doctor takes different charges from rich and poor patients in the name of operation then it is called personal price disseminator.
2. **Geographical Price Discrimination:** When goods are sold at different prices at different places it is called Geographical Price Discrimination. For example, a trader sells his product at different prices in the foreign market and in local market as in case of jumping which means to sell the product at cheap rates in foreign market.
3. **Price Determination According to Use:** When a product is sold at different prices for different utilization it is called utilization price discrimination or Trade Discrimination like every unit price of electric is high but for agriculture use, it is low.
4. **Price Dissemination According to Time:** Many public utilities industries sell one product in various rates in various times. For example, telephone department charges low rate at night or early in the morning for calling, but the call charges are high during day time.

### 13.8 Degrees of Price Discrimination

**Pigou** has divided the Price Discrimination into following three different types in his book ‘Economics of Welfare’ –

1. **Discrimination of the First Degree:** Discrimination of first degree is that discrimination in which monopolies charge different prices for every unit of goods. That particular price of every unit is determined which price a buyer wants to pay. In this way, he has **no consumer surplus**. So the determination of first degree refers to a state consumer saving in zero.
2. **Discrimination of the Second Degree is that Condition:** Discrimination of the second degree where different products are charged at different prices. For example, the state electricity board charges less for initial unit upto a limit, after that the charges are more for further consumptions of units. In this state consumer has some surplus.
3. **Discrimination of the Third Degree:** Discrimination of the third degree is that discrimination where the producer divides total market of goods into two or three groups and charges at different prices from each group. For example, if the monopolist determines the high rate of product for local market and low rate for foreign market then it is called discrimination of the third degree. In real life situation, discrimination of the third degree is more common.

### 13.9 Essential Conditions for Price Discrimination

Price discrimination is possible when the following conditions are fulfilled in the market –

- 1. Existence of Monopoly Power:** First condition of price discrimination is that seller must be a monopolist that means he must possess the power of monopoly. In the absence of monopoly power seller cannot charge more price in comparison to other sellers. The perfect competitive firms cannot charge one price for homogenous product because as per the perfect competition, there is a nature for a single price in market.
- 2. Separate Markets:** One condition is necessary for discriminating monopoly is that there must be two or more markets which can be separated and can be kept separate. Markets can be kept separate according to geographical point of view, or by brand, or by time. Persons providing personal services like doctors, lawyers etc. can charge different prices for the same service.
- 3. Difference in the Elasticity of Demand:** Price discrimination is possible when the elasticity of demand available in different markets will be different. If this happens then monopolist will determine more prices in the inelastic market, whereas he will determine fewer prices in the market of more elastic in demand. In this way he can increase his total income because there is no fear in the alteration of demand. If the elasticity of demand in different market is equal then doing price discrimination is impossible.
- 4. No Possibility of Resale:** For the existence of price discrimination it is necessary that the primary buyer of any goods or services should not be able to resale that product. It is only possible, when in one side, unit of goods would not be transferred from cheap market to expensive market, and on the other side buyers must not be able to move from expensive market to cheap market. If it happens then goods will be bought from cheap market and then it will be re-sold at expensive market, with this, the difference will be vanished which a monopolist wants to continue. That is why it is necessary for price discrimination that the unit of good must not transfer from a cheap market to a costly market. According to **Lipsey**, "The key to being able to disseminate among buyers is that discrimination among buyers requires that the goods cannot be resold by the buyer who faces the low price to the buyer who faces the high price." In summary, price discrimination can only be possible when one unit of goods cannot be transferred from cheap market to expensive market, and the elasticity of demand must be different in different markets.

### 13.10 When Price Discrimination is Profitable

Price discrimination is profitable when the price elasticity of demand is different in different markets.

If the price elasticity of demand in two markets is equal, the monopolist will not gain any profit in these two markets by price discrimination. The reason behind is when price elasticity of two markets is equal then the marginal revenue will also be equal. In opposite if price elasticity of markets is different, then the marginal revenue will also be different. In opposite if demand of elasticity is different in two markets then the marginal income would be different for goods too. The marginal income will high in a market while low in another. In this situation selling of goods at different prices by taking it out from a market of low marginal revenue to a market of high marginal revenue will be profitable. In this way due to difference in price elasticity of demand in two markets, price discrimination will be profitable. This fact can be explained with the help of following equation –

$$MR = AR \left( \frac{E - 1}{E} \right)$$

Suppose that monopolist price in market A and B is equal to ₹ 10. If at this equal monopolist price the elasticity of demand in market A and B is step 2 and 5 then according to above equation the idea of gained marginal price in these markets can be drawn by the following way -

$$\text{Marginal Revenue (MR}_A\text{) in market A} = AR \left( \frac{E - 1}{E} \right) = 10 \left( \frac{2 - 1}{2} \right) = 10 \left( \frac{1}{2} \right) = ₹ 5$$

$$\text{Marginal Revenue (MR}_B\text{) in market B} = AR \left( \frac{E - 1}{E} \right) = 10 \left( \frac{5 - 1}{5} \right) = 10 \left( \frac{4}{5} \right) = ₹ 8$$

**Notes**

Given equations clarify that due to different price elasticity in market A and B, marginal revenues is also different. In market A elasticity of demand is low i.e. marginal revenue is less i.e. ₹ 5. In opposite, the elasticity of demand in market B is more i.e. 5, hence marginal revenue (MR) is higher i.e. ₹ 8. That is why monopolist will take a unit of goods from market A, where marginal revenue is ₹ 5, and sell this unit to market B where marginal revenue is higher i.e. ₹ 8 on selling on unit more in market B. In this way monopolist will earn an amount of ₹ 3 more. He will keep doing the picking of units of goods from market A and selling them in market B, until the marginal output of goods in both markets be equal i.e.  $MR_A = MR_B$ .



*Did u know?* Price discrimination is that situation where a commodity is sold at different prices to different buyers.

### 13.11 Price and Output Determination Under Discriminating Monopoly

The aim of the monopolist in restoring to price discrimination is to increase total revenue and profit. Analysis of price determination under price discrimination can be made with reference to two or more than two market conditions there we study a situation of price discrimination in which a monopolist by selling a product at two different prices pockets a part of consumer surplus. **Pigou** has called this as “Price Discrimination of Third Degree”. Every discriminating monopolist in order to maximize his profits will produce upto that level at which marginal revenue (MR) is equal to marginal cost (MC). The monopolist will apply this condition of marginal revenue and marginal cost to get maximum profit in every market. He will do the production as long as marginal revenue is more than marginal cost ( $MR > MC$ ). We assume that the monopolist will sell his product in two different markets A and B in which the demand of elasticity is different. Discrimination monopolist has to decide (i) what is the total output to produce; (ii) how much of output is to be sold in different markets and in what price so as to get maximum profit. In order to get maximum profit the monopolist will have to take two decisions.

#### 1. How Much to Produce?

As we assume that production of the monopolist is homogenous, so he considers marginal cost of the whole production irrespective of the type of market in which he sells. He will produce upto that point in which marginal cost is equal to Combined Marginal Revenue (CMR) of the two markets. So to get estimated marginal revenue curve, the marginal revenue curves of market A and market B i.e.  $MR_A$  and  $MR_B$  are added. The monopolist will produce that much amount of the goods where marginal cost and combined marginal revenue will be equal which means,

$$MC = MR_A + MR_B = MR_{A+B}$$

#### 2. How Much to Sell in Different Markets and at What Price?

The monopolist, in order to maximize his profits, will equalize marginal cost (MC) and marginal revenue of market A is  $MR_A$  and market B is  $MR_B$  for the entire production. Figure 13.6 depicts in market A, market demand is less elastic and in market B, market demand is more elastic. This means that the

*The monopolist will sell more quantity of the product (at less price) at the time when its demand elasticity will be more and sell less quantity of the product (at more price) when its demand elasticity will be less. This is because the more the elasticity of a product is, the more is the possibility of the buyers being reduced. That is why monopolist by determining less price wants to sell more quantity of goods.*

monopolist will sell less quantity of the product ( $u$ ) of  $OA$  units at more price  $OP_1$  in market A. On the other hand, he will sell more quantity ' $OB$ ' units at less price  $OP_2$  in market B. Marginal revenue of the combined production of  $OQ$  units where combined marginal revenue is equal to marginal cost should be equal in both the markets as it should be equal to marginal cost of the entire production which means

$$MR_A = MR_B = MR_{A+B} = MC$$

Suppose if this condition will not be satisfied, if in market A in comparison to market B, MR is less, then it will be beneficial for discriminating monopolist to sell same units of market A to market B where he will gain greater marginal revenue. This activity will go on till the marginal revenue of both markets will be equal.

### 3. Price Determination

Price determination under the situation of discriminating monopolist has been explained with the help of Fig. 13.6. Figure 13.6 shows the state of equilibrium under the situation of discriminating monopoly.

In Fig. 13.6, equilibrium state of discriminating monopolist has been presented. Suppose a market has been divided into two parts A and B. As it is clear with slopes curves  $AR_A$  and  $AR_B$  that the demand in market A is less elastic than market B. In this figure,  $AR_A$  and  $AR_B$  are the demand curves for market A and B, respectively, open situation of both market (A + B) has been shown in Fig. 13.6. It is clear that at point E monopolist will be at the state of equilibrium and combined marginal revenue curve (combined MC curve) will be equal to marginal cost curve (MR curve). Total output of monopolist is  $OQ$ , and he will divide this output into two markets in a way that marginal revenue (MR) of both markets will become equal. If in one market its marginal revenue is higher then in this situation the transfer of goods from markets of less meaningful revenue would be profitable. To achieve the marginal revenue monopolist will sell  $OA$  quantity in market A and  $OB$  quantity in market B. He will sell less quantity of goods in market A in  $OP$  price of product and in market B, will sell more quantity of goods at lesser price  $OP_2$  in market B and the total quantity  $OA + OB$  of product will be equal to the total production  $OQ$  of monopolist.

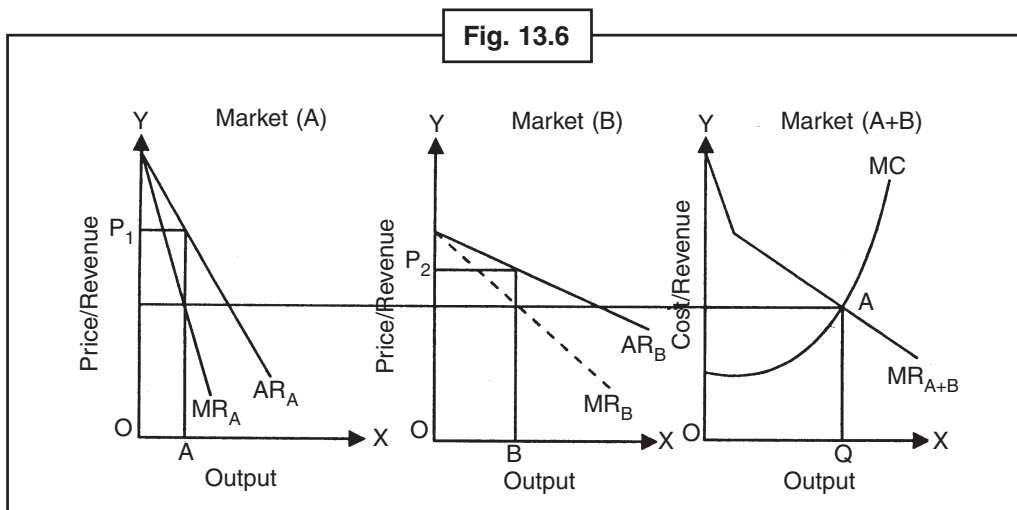

**Notes**

It is clear from Fig. 13.6 (i) **Margined cost of total production is equal to combined marginal revenue** (ii) **Marginal revenue of both markets is equal** (iii) **Marginal revenue of both markets is equal to the margined revenue of total production.**

Figure 13.6 shows elasticity of demand in market A is less than market B. So, in comparison to market B, price is high and quantity of selling is less in market A.

In brief, according to **Ferguson**, “If the aggregate market for a monopolist product can be divided into sub-markets with different price elasticities, the monopolist can profitably practice price discrimination. Total product is determined by equating marginal cost with combined monopoly marginal revenue. The output is allocated among the sub-markets so as to equate marginal revenue in each sub-market with combined marginal revenue as  $MC = MR_{A+B}$ . Finally, price in each sub-market is determined directly from the sub-market demand curve given the sub-market allocation of sales.”

**Self Assessment**

**State whether the following statements are True/False:**

9. Marginal Revenue (MR) = Marginal cost (MC).
10. Minimum Loss = AC - AVC = AEC.
11. Monopolists have to bear loss of average fixed costs.
12. During long run price is less than long run average cost.

**13.12 Dumping**

Dumping is a special form of price discrimination. Dumping means selling of goods in foreign market at less price as compare to local market. Under this situation, there exist two types of market, first one is local market where the monopolist has complete monopoly and second one is foreign market where there is complete competition. That is why monopolist can charge more for goods in local market but in foreign market he has to charge comparatively less. Dumping can be practised to achieve many objectives, like (i) for eliminating the competitors in foreign market, (ii) for gaining the profit of law of increasing returns, (iii) for creating demand of goods in foreign market, (iv) for getting relief from high stock of goods, (v) for gaining profit due to the difference in elasticity of demand.

**13.13 Price and Output Determination Under Dumping**

Price and output determination under dumping can be explained with the help of Fig. 13.7. Figure 13.7 has been drawn with the assumption of having two markets—first **local market** and second **foreign market**. In local market firm enjoys monopoly, and in foreign market it stays in the state of perfect competition. Monopolist will be at the state of equilibrium when profit will be maximum and profit will only be maximum when total marginal revenue will be equal to total marginal cost as shown in Fig. 13.7.

- (i) In the state of perfect competition, horizontal line PD represents average revenue curve ( $AR_w$ ) in foreign market. In this condition of market average revenue (Price) is equal to marginal revenue ( $AR_w = MR_w$ )
- (ii) Due to state of monopoly in local market, slope of average revenue curve ( $AR_H$ ) is downward, and slope of marginal revenue curve  $MR_H$  is also downward, and which is below to  $AR_H$ .

**It is necessary to understand for you.**  
*Under the situation of Dumping a supplier is a monopolist in local market but a complete competitor in international market. That is why slope of AR curve is downward, and of the shape of a horizontal line.*

MC is the marginal cost curve of total output of firm. How much monopolist should produce, is dependent on the fact at which point his marginal cost curve will cut the combined marginal revenue curve of local and foreign market with this point his output will be determined. Now he will divide total output into two markets in a way that the marginal revenue of every market will become equal. In Fig. 13.7 ANTD has been shown as combined marginal revenue (combined MR), in ANTD curve. AN is the marginal revenue curve of local market, with this portion of foreign market NTD has been added. Now this ANTD curve is being intersected by marginal cost curve (MC) at point T, at this point output of firm in these two markets is OM. Monopolist will now sell OL output in local market and LM output to foreign market, because by doing this the marginal revenue of both markets will become equal. Monopolist will sell OL output at price  $OP_1$  and LM output at price OP. In comparison of foreign market, the price in local market will be more.

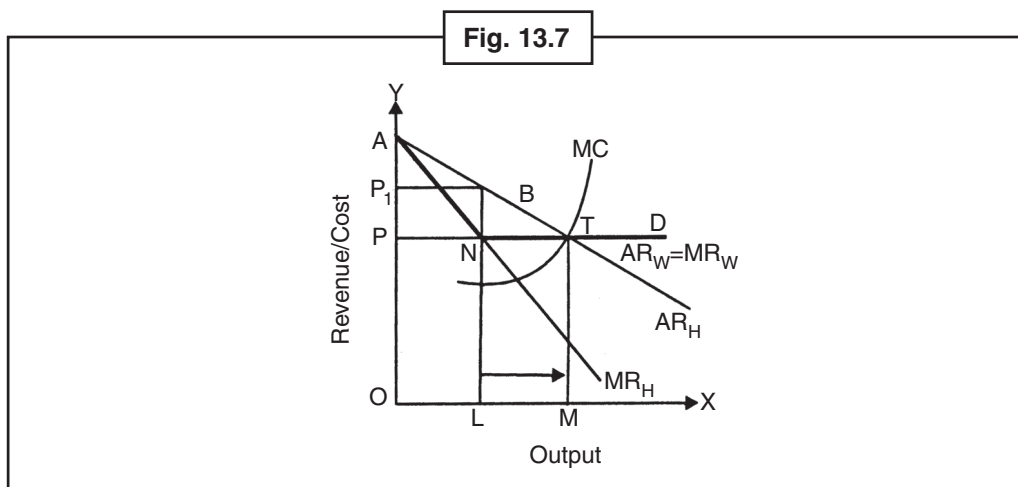

Under the condition of dumping, monopolist need to keep one thing in mind that the price in foreign market must not be determined so less that business is not able to re-import the goods which are bought by them in less price. If this will happen then there will be no profit from dumping. That is why the difference between the prices in local market to that of foreign market should be less than the transportation cost of having goods back to the country.

### 13.14 Monopoly Price with Zero Cost of Production

This is a high condition where monopolist need not to give any cost for the production of goods. Assume that monopolist has a mine, and during excavation he discovers a spring of mineral water. For monopolist the cost of this mineral water is zero under equilibrium condition marginal revenue must be equal to marginal cost (MC). Monopolist will generate this water and sell this with till the limit when marginal revenue will become zero ( $MR = MC = 0$ ). It has been explained in Fig. 13.8.

In this figure demand curve of monopolist is AR, as total cost is zero the average cost and marginal cost will also be zero. Equilibrium point is Q where marginal cost (which is zero at x-axis) is equal to marginal reserve. Monopolist firm will sell OQ unit of mineral water at price NQ per unit. Firm will have profit of NQ per unit and its area of total profit will OPNQ.

## Notes

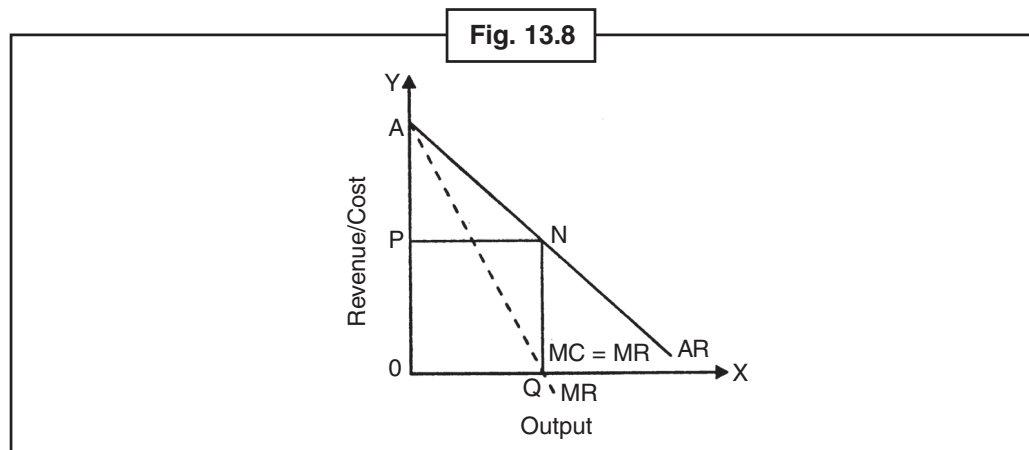

### 13.15 Is Monopoly Price Always Higher than the Perfectly Competitive Price?

Normally, comparison to competition the price is high under the condition of monopolist. This is because monopolist has the power of determining the price of goods, whereas under competition the price determination is dominated by the total demand and total supply available in market. It does not mean that monopolist price will always or necessarily be more. Some conditions are there which restricts the price to become high. In many cases, monopolist price is lower even to the price determined by perfect competition firm, for example.

- (1) Monopolist can produce on large scale, that is why monopolist can earn the surplus of large scale and profit in opposite small competition firm cannot earn the profit of surplus of large scale.
- (2) Monopolist can do production with capability and courage and can get enough amount of money at low interest for monopolist; risk on his investment is also less.
- (3) Sometime, monopolist proposes goods at low price taking public interest into consideration. Monopolist is desirous to get respect in society, and monopolist keeps himself away the work which is wrong as per social duty.
- (4) Monopolist remains in constant fear that even a competitor might not evolve. This fear restricts him from proposing high price.

**In brief normally, monopolist price is higher than complete competition, but in many situations the price may be less.**

### 13.16 Multi-plant Monopoly

A monopolist can produce upto that level in a definite size a plant at which marginal cost is equal to marginal revenue. But if the monopolist is running more than one plant then how will he distribute his total production?

Allocative principle says that marginal cost of production of different plants should be the same. This is explained with the help of an example.

Suppose there are two plants—A and B. Plant A produces 150 units per month at marginal cost of ₹ 25, whereas plant B produces 100 units per month at marginal cost of ₹ 20. Will the monopolist be satisfied this situation? Definitely not. Because if he reduces the production of plant A then he will save ₹ 25



at marginal unit and if he produces from plant B then he will have to spend additional cost of ₹ 20 at marginal unit. In this way an increasing production at B and on reducing production at plant A there will be shortage of marginal cost of 5, where the total production of the monopolist (Plant A's production + Plant B's Production) remains fixed ( $150 + 100 = 250$  units)

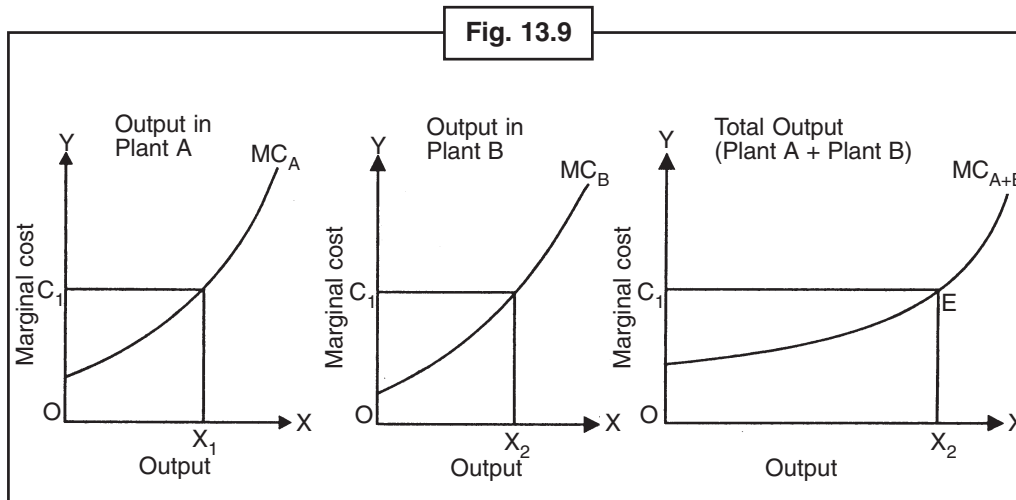

Therefore under multi-plant marginal cost curve of the monopolist is shown by addition marginal cost curve of different plants. In Fig 13.9 at definite level of marginal cost  $C_1$  which is shown equal for both plants aggregate level of production is shown, this way at marginal cost  $C_1$  total production of the monopolist is  $OX$ , which is equal to  $OX_1 + OX_2$ .

So, in the case of multi-plant the monopolist in order to determine his production and to maximize his profit makes use of aggregate marginal cost curve.



**Task** Discuss the determination of price and production in dumping.

### 13.17 Allocative Inefficiency of Monopoly/Dead Weight Loss

As it is told in the previous unit, allocative efficiency is a common feature of perfect competition. In perfect competition, consumer surplus and producer surplus are maximum and accordingly a locative efficiency is achieved.

But it does not happen in monopoly in practice, monopoly is expressed as allocative inefficiency, consumer surplus and producer surplus is not maximum in monopoly. In other words level of production is less than the production level of perfect competition and consumer and product surplus in comparison to perfect competition is less than the maximum. This situation is explained in Fig. 13.10.

In a competitive market price of the product is equal to the marginal cost in contrast in the monopoly situation price of the product is more than the marginal cost. Because as a result of monopoly power, prices are high and quantity of producer is less so condition of consumer is worse off and producer condition is better of B.

Figure 13.10 depicts demand curve (AR) and marginal revenue curve (MR) marginal cost curve represents marginal cost of the monopolist.



Notes

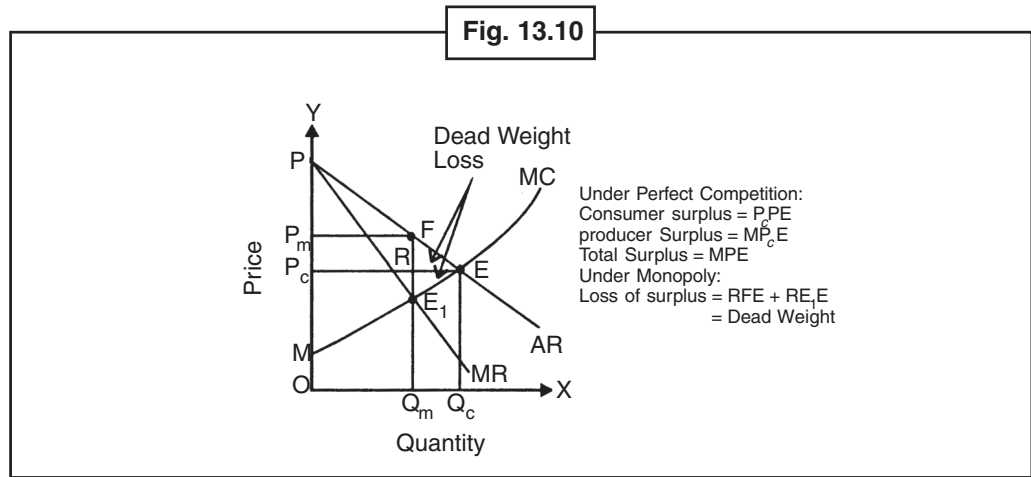

In perfect competition market marginal cost is equal to price ( $MC = Price$ ). In the figure, if we assume MC as supply curve of the firm, then point E will represent equilibrium and  $OP_c$  is equilibrium price and  $OQ_c$  is equilibrium production quantity. Price line means the above area of  $P_c$  and lower area of demand curve (AR) represent consumer surplus. The upper portion of supply curve means marginal cost curve and lower portion of price line represent producer surplus.

**In the perfect competition**, consumer surplus is equal to  $\Delta P_cPE$  area and producer surplus is equal to  $MP_cE$  area. Total surplus (consumer surplus + producer surplus) is equal to  $MPE$  area.

**In monopoly condition**, price is not equal to marginal cost. The condition for maximizing profit is equal between marginal cost and marginal revenue ( $MC = MR$ ). At this equilibrium level of production, price is determined by demand, that is average revenue (AR) curve and represents  $E_1$  equilibrium point in this equilibrium state  $OQ_m$  units are produced and they are sold at price  $OP_m$  per units.

Because, quantity of production is less than  $OQ_c$ , so there is shortage in the total surplus. As the monopolist charges high prices, so a part of consumer surplus is swallowed by monopolist. But also the society has to incur the dead weight loss. The dead weight loss is explained as –

In monopoly situation

$$\text{Consumer Surplus} = \text{area of } \Delta P_mPF$$

$$\text{Producer Surplus} = \text{area of } P_mME_1F \text{ area}$$

$$\text{Total Surplus} = \text{area of } MPFE_1 \text{ area}$$

Accordingly,

$$\begin{aligned} \text{Loss of Consumer Surplus} &= \text{area of } \Delta P_cPE - \text{area of } \Delta P_mPF \\ &= \text{area of rectangle } P_cP_mFR + \text{area of } \Delta RFE \end{aligned}$$

The monopolist pockets, out of this loss of consumer surplus, area equal to area of the rectangle  $P_cP_mFR$  because he charges more price than price of perfect competitor then also, the society has to incur loss equal to area of  $\Delta RFE$ , although, the monopolist has swallowed some parts of consumer surplus (area of rectangle  $P_cP_mFR$ ) yet a part of producer surplus (area of  $\Delta RE_1E$ ) which is in state of perfect competition is received by him, assumes the form of pure dead loss.

In monopoly situation the total loss = area of  $\Delta RFE$  + area of  $\Delta RE_1E$ .

When the monopoly power exists in the market then this loss is evitable. That is why the government generally tries to control monopoly system.

### 13.18 Supply Curve of a Firm Under Monopoly

In perfect competition that part of marginal cost curve which lies above the average variable cost curve, is short run supply curve of the firm because at a price less than the average variable cost the firm cannot realize even its variable cost and it shuts down its production.

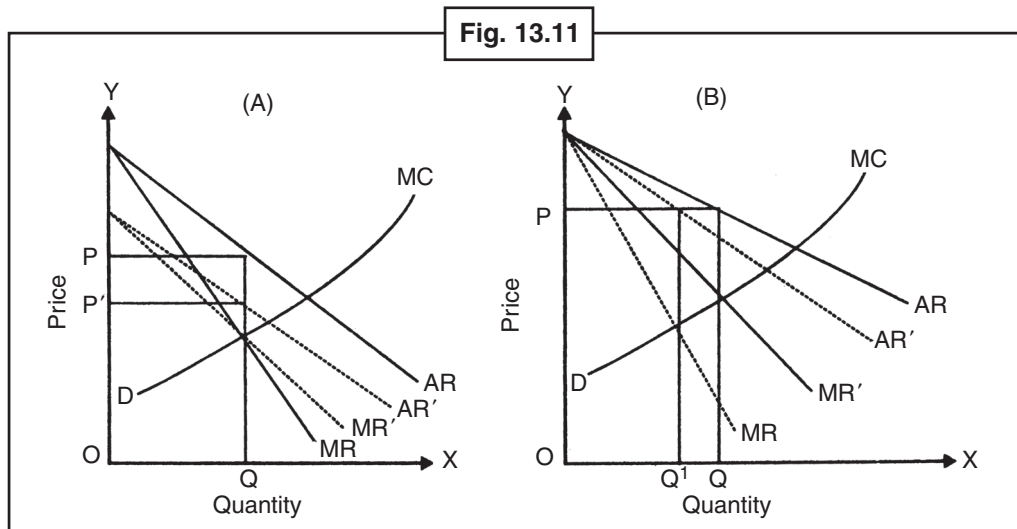

But this does not apply to monopoly firm. The monopoly firm (as a result of monopoly power) determines its price itself taking into consideration degree of demand price dissemination, that is charging different prices from different buyers is also one of the main characteristics of the monopoly as a result, supply curve becomes undeterminable as shown in Fig. 13.11.

In this figure AR and MR are revenue curves of market 1 and AR' and MR' are revenue curves of market 2. In Fig. 13.11 (A) it is shown that OP price of OQ quantity of the product is charged in Market 1 and OP price is charged for the same quantity in market 2. Figure 13.11 (B) shows that at the same price OP, OQ quantity of the product is sold in market 1 and OQ' quantity is sold in market 2 it means that a monopolist firm can sell different quantities of the product at a price or charge different prices for the same quantity in different markets. As a result in monopoly the question of a single supply curve does not arise.

### 13.19 Summary

- The English word 'Monopoly' is derived from the Greek word 'Monopolian'. It means right to sell. So the pure monopoly is the situation of the market in which only a single firm is the only producer of any product and that product does not have any close substitutes. As monopolist is the only seller of product in the market thus neither he has any rivals nor any competitors.

### 13.20 Keywords

- **Price Maker:** One who determines the price of the production.
- **Price Discrimination:** Different prices.
- **Short Run:** Short Time

Notes

**13.21 Review Questions**

1. What is monopoly? Explain it.
2. What do you mean by total income and the view of total cost?
3. What is meant by marginal revenue and marginal cost view?
4. Describe the necessary conditions of prices discrimination?

**Answers: Self Assessment**

- |          |               |          |           |
|----------|---------------|----------|-----------|
| 1. Price | 2. Monopolian | 3. Below | 4. Seller |
| 5. (a)   | 6. (b)        | 7. (d)   | 8. (a)    |
| 9. True  | 10. False     | 11. True | 12. False |

**13.22 Further Readings**



*Books*

1. **Microeconomics** – Frank Cowbell, Oxford University Press, 2007.
2. **Microeconomics** – Shipra Mukhopadhyay, Annie Books, 2011.
3. **Microeconomics: An advanced Treatise** – S.P.S Chauhan, PHI learning.

## Unit-14: Theory of Monopolistic Competition

### CONTENTS

Objectives

Introduction

- 14.1 What is Monopolistic Competition?
- 14.2 Characteristics of Monopolistic Competition
- 14.3 Profit Maximization or Equilibrium Under Monopolistic Competition  
or  
Determination of Price and Output Under Monopolistic Competition
- 14.4 Short-Run Equilibrium in Monopolistic Competition
- 14.5 Long-Run Equilibrium in Monopolistic Competition
- 14.6 Excess Capacity
- 14.7 Is Excess Capacity Wasteful?
- 14.8 Empirical Evidence
- 14.9 Non-price Competition
- 14.10 Selling Costs
- 14.11 Summary
- 14.12 Keywords
- 14.13 Review Questions
- 14.14 Further Readings

### Objectives

After studying this unit, students will be able to:

- Know about Monopolistic Competition.
- Read about Excess Capacity.
- Know about Non-Price Competition.
- Know about Selling Costs.

Notes

**Introduction**

Till now we have studied two ultimate conditions of market – perfect competition and monopoly. But in actual life, middle condition is found, which is known as **Imperfect Competition**. In economics, conditions of imperfect competition were studied after 1993. This year, in England, book *Economics of Imperfect Competition* of **Ms. Joan Robinson** and in America, book *Theory of Monopolistic Competition* of **Chamberlin** have been published. Imperfect Competition is a wide term in which following situations of market are included (1) **Monopolistic Competition**: many sellers come under it. (2) **Oligopoly**: only some sellers come under it. (3) **Duopoly**: only two sellers come under it.

**14.1 What is Monopolistic Competition?**

**Monopolistic Competition is that condition of market in which there are many sellers of any commodity but commodity of every seller is different from commodities of other sellers in any way. Therefore, product differentiation is main quality of monopolistic competition.** Product differentiation can be in the way of brand’s name, trademark, differences in properties, packing or services given to customer or differences in services. Many examples of this type of competition are found in actual life. Firms producing toothpaste like Forhans, Colgate, Pepsodent, Cibaca, Babool etc. are the examples of monopolistic competition. In this type of market situation, there are firm monopolies and also the competitor, firm monopolies are there because it has limited control on commodity due to the product differentiation. In accordance with, demand curve of every firm like monopoly is negative. For example, Lux trademark of Hindustan Lever Ltd. has monopoly. Any other firm cannot use it. But other firms can produce bath soap like Hamam, Breeze, Camay, Dettol etc. under its trademark. In other words, there is freedom of producing substitute of ‘Lux’ soap. In this situation of market, element of competition is due to many sellers of commodity and firms have the freedom of entry and exit.

According to **J. S. Bains**, “**Competition is found in the industry where there is a large number of small sellers, selling differentiated but close substitute products.**”

In the words of **Baumol**, “**The term monopolistic competition refers to the market structure in which sellers do have a monopoly (they are the only sellers) of their own product, but they are also subject to substantial competitive pressures from sellers of substitute product.**”

**Self Assessment**

**Fill in the blanks:**

1. As a result of product differentiation ..... partial restriction on price.
2. Product differentiation is the ..... of monopoly.
3. Sources of production and commodities and ..... not in monopolistic competition.
4. Cost of every firm is affected by ..... cost of its competitors in market for a long time.

**14.2 Characteristics of Monopolistic Competition**

Following are the main characteristics of Monopolistic Competition –

1. **Large Number of Firms and Buyers:** Firm producing differentiated product and sellers are large in numbers in monopolistic competition.
2. **Product Differentiation:** Product differentiation is the main feature of monopolistic competition. Product differentiation means that product of different types, brands, and qualities will be available to customers in a fixed time period. Product differentiation occurs when buyer of product can differentiate between two products. In this, firms are in large number but their products are different

from each other in anyway, but these products are close substitutes of each other. Product differentiation is obtained due to characteristic of product like shape, measurement, colour, durability, quality etc. There are many examples of product differentiation like bath soaps Lux, Godrej, Camay, Rexona, etc. in tea, Lipton, Brooke Bond etc., in toothpaste, Pepsodent, Colgate, Forhans etc.

3. **Freedom of Entry and Exit of Firms:** In the situation of monopolistic competition there is freedom of entry and exit of firms in the industry like perfect competition. It should be noticed that Chamberlin has used **group** at the place of **industry** for group of firms which produce differentiated products under the monopolistic competition.
4. **Selling Cost:** An important characteristic of monopolistic competition is that every firm spends more money in promoting its product under it. Firm gives advertisements in newspapers, cinemas, magazines, radio, T.V. etc. for selling its product in the maximum amount. The investment done on all these is called as Selling Costs.
5. **Price Control:** Every firm has limited control on the cost of product. Average income and limit-end income curve of a firm fall down like monopoly in monopolistic competition. It means that in this situation, firm can slow down the price for selling more products and raise price for fewer products. In monopolistic competition, a firm has control on cost of its production due to the product differentiation. But due to the availability of close substitute of opposite product firms do not have full control on cost in monopolistic competition. The cost of every firm is affected by cost policy of its competitors in market up to the certain limit.
6. **Limited Mobility:** In monopolistic competition, sources of production and products and do not have mobility in services.
7. **Imperfect Knowledge:** In the situation of monopolistic competition, buyers, sellers of products, and owners of sources do not have knowledge of different prices of product. The reason is that comparison between productions of different firms is not possible due to product differentiation. Customers are fond of the production of any one specific firm. They only buy the production of that firm even if it costs higher than others. In this way even sources of production are not able to know fully that how much the different firms are costing to the sources of services.
8. **Non-Price Competition:** The main characteristic of monopolistic competition is that under it different firms without changing the costs of products compete with each other like the example of companies producing 'Surf' and 'Ariel'. If you take a box of 'Surf', you will get a glass utensil similarly, with the box of 'Ariel' you will get the steel spoon. In this way, firms, by providing different types of facilities and products etc. to customers to attracts them toward their products. This type of competition is called as Non-Price Competition.

**Why do Producers want to Differentiate their Production?**

- As a result of product differentiation, partial restriction is possible on cost.
- As a result of product differentiation, possibility increases of increase in part of producer in selling in market.

### 14.3 Profit Maximization or Equilibrium Under Monopolistic Competition

or

### Determination of Price and Output Under Monopolistic Competition

Intention of every production is to make maximum profit even in the situation of monopolistic competition. We have already seen that maximum profit occurs when marginal revenue is equal to marginal cost. Marginal revenue is not equal to average revenue like perfect competition in the situation of monopolistic competition. In the situation of monopolistic competition, if any firm wants to sell maximum quantity of its production then it has to decrease the cost. That's why, in the situation of monopolistic competition,

**Notes**

Average Revenue Curve (AR Curve) and Marginal Revenue (MR Curve) fall down in the form of left to right. In monopolistic competition, a firm produce till the point or limit at which (i) Marginal Revenue is equal to Marginal Cost ( $MR = MC$ ) and (ii) Marginal Revenue Curve cuts Marginal Cost Curve from the lower side. In this situation firm is in the condition of balancing by the production. The study of equilibrium firm in monopolistic competition can be done in two different durations –

(1) Short Run and (2) Long Run



*Notes* Monopolistic Competition is that situation of market in which there are many sellers of the commodity but commodity of every seller is different from commodities of other sellers in any form.

**14.4 Short Run Equilibrium in Monopolistic Competition**

Short Run is that duration of time in which production can be increased only by increase in using variable resources on increasing demand. There is no time to increase or decrease constant resources of production like machine, plant, building, etc. In short run, an equilibrium of a firm will be in that situation in which (1)  $MC = MR$  and (2)  $MC$  curve will be cutting  $MR$  curve. In short run, the amount of profit obtained in situation of equilibrium production to the firm will depend on demand of commodity and work welfare. There can be three conditions of firms in this duration of time –

(1) **Super Normal Profits**, (2) **Normal Profits** and (3) **Minimum Losses**. Short minimum term equilibrium condition of firm of monopolistic competition can be explained by the leading figure.

**The similarity of the MR and MC-balance is the standard condition**

*Standard condition of similar equilibrium of MR and MC is in the condition of maximum profit and minimum loss of monopoly and perfect competition in monopolistic competition is also  $MR = MC$*

- 1. Super Normal Profits:** It is known from Fig. 14.1 that firm is in equilibrium at point E because marginal cost and marginal revenue are equal ( $MR = MC$ ) on point E and  $MC$  curve cut  $MR$  curve from the lower side. It is known by point E that  $OM$  will be equilibrium production of firm. The cost of equilibrium production is  $OP (= AM)$ . The cost ( $AM$ ) of equilibrium production will be more ( $AM > BM$ ) than average cost  $BM$  so every unit of firm is obtained Super Normal Profits  $AM - BM = AB$ . In the situation of equilibrium, firm has total super normal profit  $ABCP$ , which has been shown by shaded parts.

**Fig. 14.1**

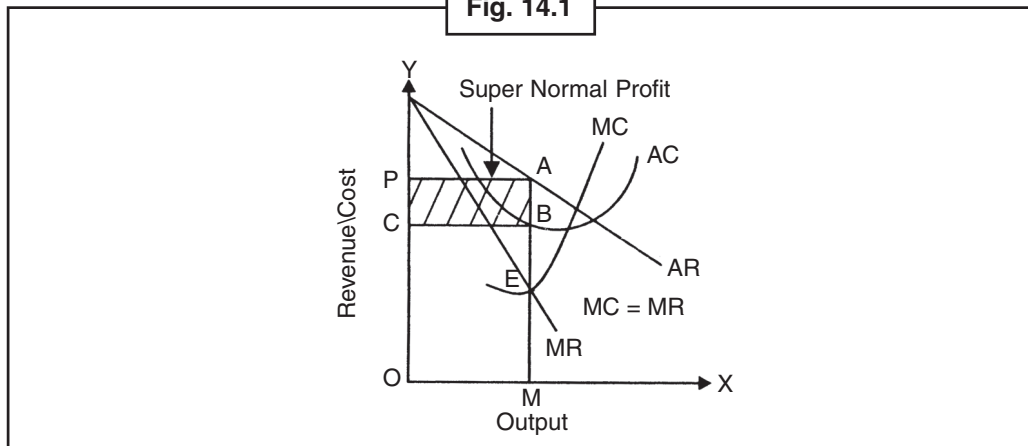

2. **Normal Profits:** In short-run, firm of monopolistic competition can have the normal profits. It is known by Fig. 14.2 firm will be in equilibrium situation at point E because at point E (i)  $MC = MR$  and (ii)  $MC$  curve cuts  $MR$  from the lower side. It is known by point E that  $OM$  will be the equilibrium production. The cost of equilibrium production is  $OP$  ( $AM$ ) and average cost is also  $OP$  ( $AM$ ). The reason is that  $AR$  curve is touching  $AC$  curve at point A. That's why in the situation of equilibrium cost ( $AR$ ) and average cost ( $AC$ ) are equal ( $AR = AC$ ). Therefore, only normal profits will obtain to firm.

Notes

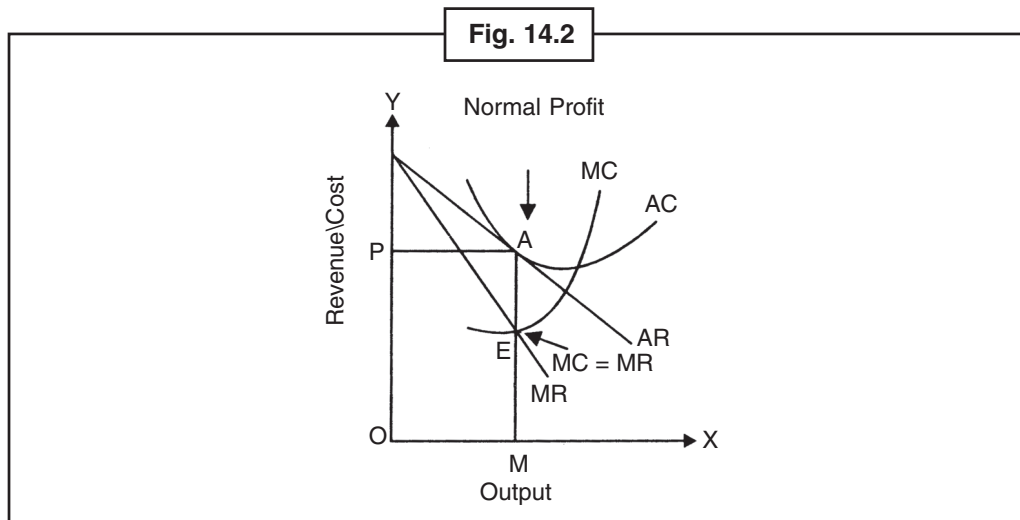

3. **Minimum Loss:** Firm can also have loss of fixed cost in short-run. This is the minimum loss of firm. It is known from Fig. 14.3 that firm will be in equilibrium at point E. At this point,  $MC = MR$  and  $MC$  curve cuts  $MR$  curve from the lower side. In the equilibrium condition, firm will produce  $OM$ . The cost of equilibrium quantity  $OM$  is  $OP$  ( $= AM$ ) and average cost  $OC$  ( $= NM$ ). A short-run average cost of firm more than ( $SAC > AR$ ). So firm will have per unit loss of  $NM - AM = AN$ . But the cost of equilibrium production  $OM$  is equal to increased-decreased average cost because  $AR$  curve is touching  $AVC$  curve at point A. So, firm will obtain increased-decreased average cost equal to  $AM$  but will have loss of fixed cost  $AN$ . Total loss of firm will be  $NAPC$  which has been denoted by shaded part.

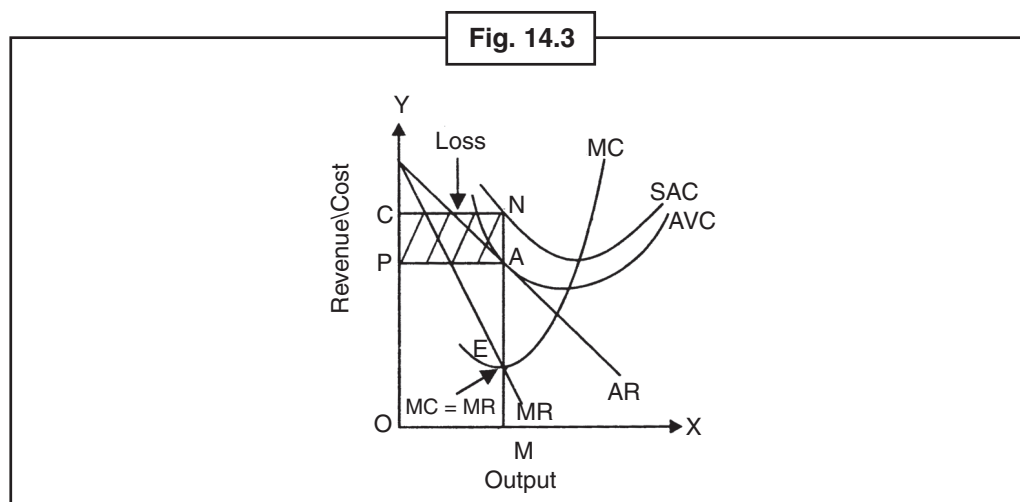



## 14.5 Long-Run Equilibrium in Monopolistic Competition

Long-term is that duration of time in which firms can change level of their plants, new firms can enter into the market and old firms can leave the market. It should be kept in mind that **products differentiated** in monopolistic competition are not similar. **Chamberlin** had used the word product group at the place of industry to those firms which produce differentiated product. There is freedom of entry and exit of firms in '**product group**'. Because there is freedom of entry and exit of firms in monopolistic competition so all the firms obtain only normal profit producing at higher level of profit in the situation of long-run equilibrium. It is assumed that demand and cost curves for all products are uniform throughout the group. In long-run, in the condition of monopolistic competition (i) firms do not earn super normal profits (ii) firms do not have loss (iii) firms earn only normal profits. These can be described as follows—

- (1) **Firms will not Earn Super Normal Profits:** If in the situation of monopolistic competition, firms earn super normal profits so new firms will enter into the product group. They will produce nearby substitutes. When new firms attract customers of recent firms then demand of production of recent firms will become less. As a result, cost will decrease. Entry of new firms will continue in the market till when firms have not been earning the super normal profits. In other words, in long-run due to the freedom of entry of firms super normal profits are not earned. Yet, every firm has monopoly in its differentiated product but due to the competition of conflicted firms producing nearby substitutes they are compelled to produce only in the situation of normal profits.
- (2) **Firms will not incur loss:** No firm will incur loss in long-run. If any firm is getting loss in long-run then it will be better to stop their production and exit from the group. This will decrease the level of production, accomplishment will be less in comparison of demand, cost will increase and firms will earn normal profits again.

### Why only normal profits are obtained in long-run?

*The reason is that like perfect competition there is freedom of entry and exit to firms in monopolistic competition also.*

The cost determination in long-run can be clarified by Fig. 14.4.

In Fig. 14.4 LAC is long-run average cost curve and LMC is long-run marginal curve. AR is lead average and MR is marginal lead curve. MR and MC at point E are equal to each other. Therefore, it will be equilibrium point. OM will be produced on this point, which costs OP(=AM). Average revenue curve on equilibrium production OM is touching long-run average cost curve at point A. So, in the equilibrium condition, cost and long-run average cost (AR = LAC) are equal to each other. Therefore, firms are earning only normal profits. There will be maximum profits of LAC and AR at 'A', Point of Tangency.

The reason is that on any other cost average cost (AC) is more than average revenue (AR) of long-run average cost curve (AR) so firm will incur loss. Due to the normal profits obtained by the firm, there will be no encouragement for the entry of new firms in the group and no reason for exit of old firms from the group.

By viewing the Fig. 14.4, one more important thing is cleared that firm cannot use its fullest capacity on equilibrium point means production level of firm on equilibrium point is not optimum. The reason is that the average revenue curve falling down cannot touch U-shaped long-run average cost curve to its optimum point. Average revenue curve is parallel to OX-axis in perfect competition, so it touches average cost on its optimum point on equilibrium point. But in monopolistic competition AR curve because of its negative slope touches U-shaped LAC curve to its point of highest cost, like it is known from Fig. 14.4. Therefore, in monopolistic competition long-run average cost is not optimum on equilibrium point. That's why firm production on equilibrium point is also optimized.

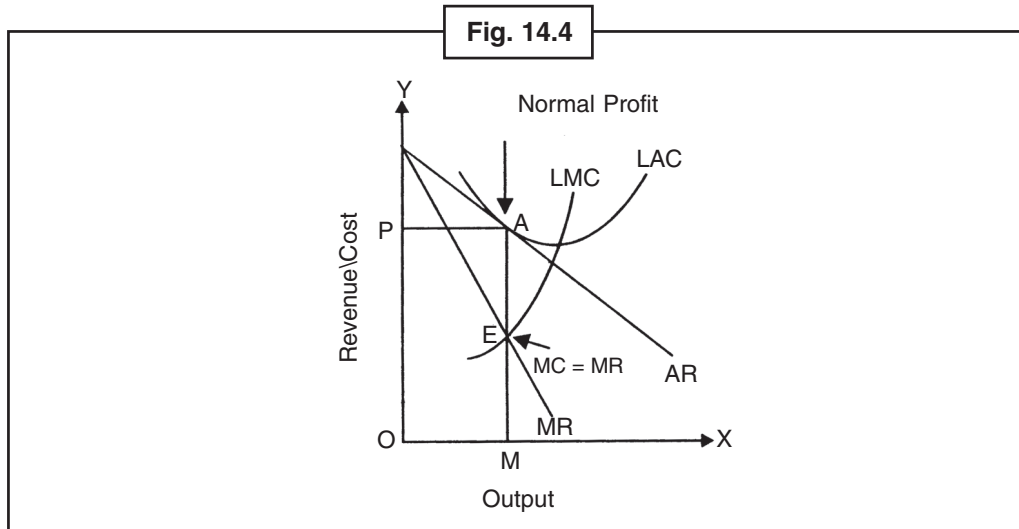

### Self Assessment

#### Multiple choice questions:

5. Intension of every producer even in monopolistic competition is to be ..... .  
 (a) more                      (b) less                      (c) zero                      (d) none of these
6. There ..... of entry and exit of firms in the situation of monopolistic competition.  
 (a) dependence              (b) freedom              (c) equality              (d) inequality
7. It is found in firms in monopolistic competition ..... .  
 (a) freedom              (b) equality              (c) excess capacity              (d) dependence
8. Under cost competition, firms do to cost ..... .  
 (a) more                      (b) zero                      (c) less                      (d) none of these

### 14.6 Excess Capacity

A quality of long-run equilibrium is 'Excess Capacity' found in 'group.' In the words of **Mansfield**, "Excess capacity is the difference between optimum output and the actual output in the long run equilibrium. **Optimum output of a firm has been regarded to be the output where long-run average cost is minimum.**"

*The concept of excess capacity is long-run concept because in short-run only perfect competition firm can use it less than optimum.*

**Excess Capacity** is found in firms in monopolistic competition because it does not produce at optimum point of long-run average cost curve. In other words, excess capacity is that capacity which is not used in production. In this situation, every firm produce more and more on average cost than its average cost of optimum production. Concept of excess capacity can be explained by the Fig. 14.5.

It is shown Fig. 14.5 that firm is in long-run equilibrium condition at point E.  $LMC = MR$  and AR curve is touched line of LAC curve at this point. Equilibrium or Actual output is OQ. Optimum output is  $OQ_1$ . The difference between optimum output and actual output represents the **excess capacity**.

Notes

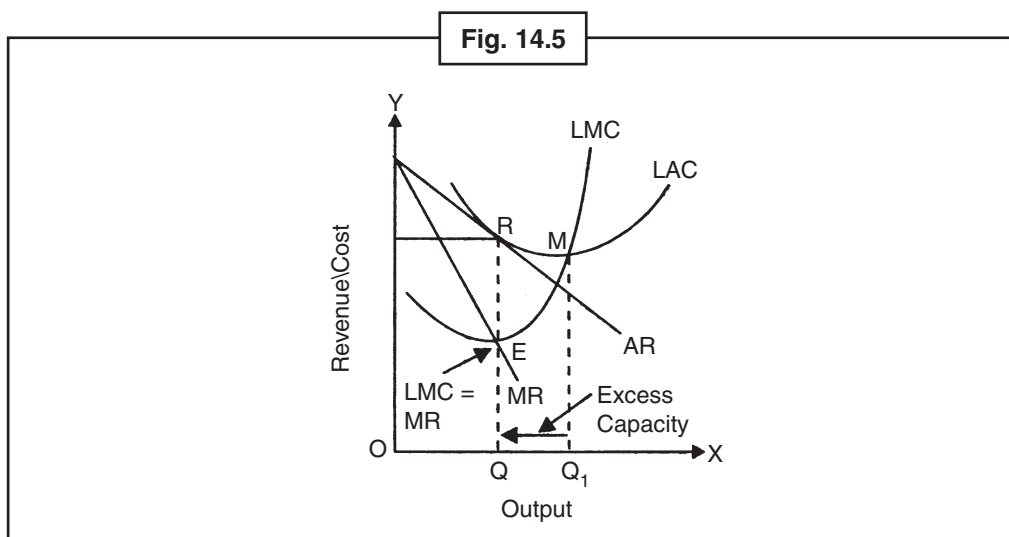

$$\text{Excess Capacity} = \text{Optimum Output} - \text{Actual Output}; QQ_1 = OQ_1 - OQ$$

The reason for the rise of excess capacity is that in long-run equilibrium downwards bended AR curve touches U-shaped AC curve to left of its optimum point. Tangent point 'R' is upper than optimum point 'M' means cost is more than average cost and less than optimum output ( $OQ_1$ ) means it is  $OQ$ .

 *Did u know?* Optimum Output is that output on which long-run average cost is optimum.

### 14.7 Is Excess Capacity Wasteful?

It is a subject to dispute that whether excess capacity is wasteful or not. The vote of some economists is that as a result of 'excess capacity' number of firms is large in 'group'. Because every firm produces less than the optimum production so firms can be more than necessity in the 'group' only in the situation of 'excess capacity'. As a result of it, there is extravagance. Because every firm is producing on the part of negative slope of average cost curve so production is done on more than the cost. That's why use of recent production capacity of firm cannot be done. Due to the reason, concepts of some economists are that excess capacity is wasteful. In its absence, production of equal quantity of products will be possible by the less number of firms because more production will be done by every firm. As a result, production cost will be less. Every firm will produce more quantity of product on less average cost.

Opposite to it, some economists, like **Kelwin Lancaster** does not admit this opinion that monopolistic competition is wasteful. According to him, under monopolistic competition, as a result of production of differentiated product it will be possible to increase their satisfaction on satisfying different interests of customers.

Related to it, **Lipsey** said that, "Consumers' satisfaction are maximized when the number of differentiated products is increased until the marginal gain in consumer's satisfaction from an increase in diversity equals the loss from having to produce each existing product at higher cost."

We conclude that 'excess capacity' is not wasteful.

**Self Assessment**

Notes

State whether the following statements are True/False:

9. Economist, **Kelvin Lancaster** admits the opinion that monopolistic competition is wasteful.
10. Product differentiation is not generally a global phenomenon.
11. Non-price competition is that competition in which sellers do conflicts for selling through other methods in the place of decreasing cost.
12. Selling costs are those costs which are used for the intension of changing in the situation and shape of demand curve of any product.

**14.8 Empirical Evidence**

Product differentiation is the global phenomenon. Actually, a mandatory condition of reaction of production is made in all economies of the world in protracted time. Increase and globalized reaction in international competition have made the thought of product differentiation very hard. Undoubtedly, product differentiation is the distinct quality of monopolistic competition even then it is believed that monopolistic competition (a kind of market) is not more extensive in market. Actually, the economists believe that there may be any monopoly behaviour present in market. How can we coordinate both the facts: One is that the product differentiation is expanding as market behaviour; second, the monopoly competition (production differentiation is the main characteristics of it) is not seen in real life. The reality is that there are fewer firms which differentiate the production of product. The product differentiation much occurs in consumer goods like Soap, Cigarette, Chemical and Fast Food. But these products have been produced by those big firms whose quantity is very low. McDonald's, Pizza Hut, Sub way, Dominos and KFC are some firms which are brands in processed food items. How this industry can add in the market? Definitely, this is not perfect competition or monopoly or monopolistic competition. The place for this is that place of market which is called Oligopoly and the main characteristic is competition among the few firms. This is described in next unit.



*Task* Give your opinion in Excess Capacity.

**14.9 Non-price Competition**

The firms can opt two methods in monopolistic competition to raise its profit – (i) Price Competition (ii) Non-price Competition. In price competition, firm decreases its price. By this there may be no profit maximization because if a firm decreases its price, other firms also do this technique. Thus, the part of any firm doesn't go ahead because there is no sale increment in either of the firms. So in the monopolistic competition, firms mostly opt non-price competition.

In the words of **Nicholson**, “**Non-price competition is the competition by sellers for sales by means of other than price cutting.**”

The non-price competition means the technique which firms adopt without changing the price of product to lure the customers.

There are many ways by which the firms use to attract the customer like to change the quality of product, change in the place of sale, to give advertising, to give free gift with product like spoon, calendar, glass, ball pen etc., goods packaging, free home delivery etc. Thus every firm uses these techniques to attract the customers by giving such services. This competition is called non-price competition.

**Notes**

In the non-price competition, the main aim of firms is also to increase its profit and sale. This competition works till customer demand is not fulfilled. By this, consumer gets various products in attractive terms. But sometimes this non-price competition starts **Cut-Throat Competition** in mutually against firms and the **social cost** of these competition gets higher. In monopolistic competition, the unusual profit gets zero in long run due to independency of firm to get in. But sometimes the firms deny to get into the new firm by differentiating their production.

### **14.10 Selling Costs**

The monopolistic firms spend more of their money in advertising to sell more of its product. The cost which goes into publicizing and advertising the product, in economics this is called selling cost. The selling cost is main necessity in monopolistic competition. In perfect competition, all the products of all the producers are homogenous. So they do not need advertisement of product. In monopoly condition also, there is only one producer of product. When he starts production, then he may be spending some money to give information about product to consumer. This money is only an information which is spent in advertisement. When the consumer gets knowledge about the product, the advertisement technique has no need. In monopolistic competition, it is not enough to give information of the product only but to remember the quality of product is very necessary. So in monopoly condition, this selling cost is not only for informative purposes, but also for manipulative demand and sales promotion. In brief, the selling cost has all the processes which a producer uses for **manipulative** demand or to **increase his demand** of product. So the selling costs are those which are spent on advertisement, salesmanship, commission given to the shopkeepers, gifts and benefits etc.

According to Chamberlin, "Selling costs are costs incurred in order to alter the position or shape of the demand curve for the product."

According to Meyers, "Selling cost may be defined as costs necessary to persuade a buyer to buy one product rather than another or to buy from one seller rather than another."

### **14.11 Summary**

- The main characteristic of monopolistic competition is that under it different firms without changing the costs of products compete with each other like the companies producing 'Surf' and 'Ariel'. For example, if you take a box of 'Surf', you will have a glass utensil similarly, with the box of 'Ariel' you will get the steel spoon. In this way firms, by providing different types of facilities and products etc. to customers, attract them toward their products. This type of competition is called as non-price competition.

### **14.12 Keywords**

- **Monopolistic:** Full rightful
- **Selling Cost:** Cost of Selling
- **Price Control:** Limited control on price
- **Imperfect Knowledge:** Half Knowledge

**14.13 Review Questions**

Notes

1. What do you mean by monopolistic competition? Describe it.
2. What do you mean by excess limit? Describe it.
3. What do you mean by empirical evidence?
4. Give a note on 'non price competition'.

**Answers: Self Assessment**

- |             |                         |           |          |
|-------------|-------------------------|-----------|----------|
| 1. Possible | 2. Main characteristics | 3. Motion | 4. Law   |
| 5. (a)      | 6. (b)                  | 7. (c)    | 8. (c)   |
| 9. False    | 10. False               | 11. True  | 12. True |

**14.14 Further Readings**

Books

1. **Microeconomics: An Advanced Treatise** – S.P.S. Chauhan, PHI Learning.
2. **Microeconomics: Behaviour, Institutions and Evolutions** – Sampool Bowels, Oxford University Press, 2004.
3. **Microeconomics: Principles, Applications and Tools** – Sanjay Basotia, DND Publications, 2010.

## Unit-15: Theory of Oligopoly

### CONTENTS

Objectives

Introduction

15.1 Features of Oligopoly

15.2 Behaviour of Oligopolistic Firms and Other Market Structures

15.3 Classification of Oligopoly

15.4 Why Bigness? Or What Causes the Emergence of Oligopoly?

15.5 Summary

15.6 Keywords

15.7 Review Questions

15.8 Further Readings

### Objectives

After going through this unit, the students will be able to:

- Know the importance of oligopoly.
- Discuss behaviour of the market.
- Do the classification of oligopoly.
- Explain other forms of market.

### Introduction

A form of market in which the competition takes place only between some firms, is a new and emerging phenomenon. The number of goods producing firms is less and they compete with each other. Not in local but often in international market the competition is so acute that economist often relates it with cut-throat competition. This type of market is known as oligopoly market. Example: (i) There is an ongoing competition between Coke, Pepsi and Canada Dry and some other soft drinks throughout the world. (ii) There is a worldwide competition between General Motors, Toyota, Maruti Suzuki, Hyundai, Ford and some other car manufacturers.

**Lipsey** has defined oligopoly as “Theory of imperfect competition among the few; it refers to an industry that contains only a few competing firms. Each firm has enough market power to prevent its being a price taker; but each firm is subject to enough inter-firm rivalry to prevent it considering the market demand curve as its own.”



*Notes* Oligopoly cross elasticity of demand of commodities is much higher. Because these items are near replacement.

Notes

## 15.1 Features of Oligopoly

Features of oligopoly are as follows:

1. **Few sellers and many buyers:** Oligopoly is that condition of the market in which only few firms have their influence. For example, in India, four companies Maruti, Hyundai, Cielo and Tata produce 90% of the small cars. Products produced by oligopolistic firms can be homogeneous or discriminatory. These firms can influence prices and production with their actions. In Oligopoly, the number of buyers is very large.
2. **Homogeneous or Differentiated Product:** In Oligopolistic industry, firms either produce homogeneous or differentiated products. If the firms produce homogeneous products, like cement or steel, the industry is known as Pure or Perfect Oligopoly and if the firm is producing differentiated product, the industry is called as differentiated or imperfect oligopoly.
3. **Mutual Interdependence:** The interdependence of firms is an important feature of Oligopoly. Interdependence means that the firms get affected by each others' prices and production related decisions. In monopoly and competition, the firms can take their decisions independently and can work upon them without taking into consideration what effect would that have on other firms or how would other firms' reactions affect them. But an Oligopolistic firm cannot take an independent decision. As a small number of firms compete with each other in Oligopoly, the sales of a firm depend on the price taken by the firm itself as well as on the price taken by other firms. If a firm reduces its price, its sales tend to increase but the sales of other firms tend to decrease at the same time. In such a situation, it is possible that other firms may reduce their prices as well which might decrease the profit of the first firm. Therefore, a firm must calculate and predict the reaction of other firms as well as the effect of those reactions, before reducing its prices. The cross elasticity of goods in Oligopoly is very high as these goods are easily replaceable. To summarize, the Oligopolistic firms have to keep in mind the competitors' actions and reactions while deciding upon price and production. This mutual interdependence of the firms makes the Oligopolistic market different from monopoly, complete competition, and monopolistic competitor.
4. **Lack of Uniformity:** The absence of uniformity in the size of firms is another feature of Oligopoly. Some firms are very large and some are small firms. For example, Maruti holds 86% of share in the market of small cars; whereas Hyundai and Tata hold a relatively small share.
5. **Advertisement:** A huge firm has to shell out a lot of money on advertising. Due to the price rigidity and cross elasticity of demand, advertising the product is the only means for a large firm to magnify its sales volumes. A large firm's primary objective of investing huge sums of money on advertising is to stimulate the demand for its product. In this context, Baumol has rightly said, "It is only in oligopoly; advertisement comes, fully into its own. Under oligopoly, advertising can become a life and death matter, where a firm which fails to keep up with the advertising budget of its competitors may find its customers rifling of to rival products."
6. **Element of Monopoly:** Schismatic and incomplete Oligopoly firms have the power of monopoly. Product distinction creates the sense of **brand loyalty** in consumers. Every firm has the monopoly over its brand. No other firm can sell a product within that **brand** (trademark). Other than this, firms can earn monopolistic profits by increasing prices through collusion.



Notes

7. **Existence of Price Rigidity:** Existence of price Rigidity is another feature of Oligopoly. Price rigidity means no change in the prices by the firms. Because any change in the price would not be profitable for the firm, therefore, a firm sticks to its prices. If a firm tries to reduce its prices, in return its competitors would reduce their prices as well yielding no profits for any firm. In the same way, if a firm tries to increase its prices, it will end up losing its customers and in turn facing losses. Hence, price rigidity is witnessed in Oligopolistic market.
8. **Keen Competition:** There is an acute competition between the competitors in Oligopoly. The number of sellers is so less that a step taken by any firm affects other participants immediately. Consequently, each firm monitors the activities of its competitors and is always ready with its defensive actions. For an oligopolist, business is a continuous struggle because the market situations make him face every move in the market. This type of competition is unique and cannot be found in other markets. Oligopoly is the highest form of market.
9. **Uncertainty:** Due to the mutual interdependence of the firms, it is not possible to predict the behaviour of any firm. Based on the existing facts, it is very difficult to estimate the current financial changes. Therefore, uncertainty always exists in Oligopoly.
10. **Existence of Non-profit Motive:** In Oligopoly, maximum profit is not the only motive of a firm. There can be other motives like – sales maximisation, minimisation of risk, output-maximisation, security maximisation, etc. It is very difficult to determine the balance between price and production in case of absence of maximum profits as a motive.
11. **Some Barriers to Entry:** The restrictions on entry into the industry of the Oligopolistic firms are another feature. Some general restrictions are – scale of savings, absolute costs profit to old firms, control over patent rights importance inward, existence of preventive prices and excess capacity, etc. The above mentioned barriers stop the entry of new firms.

Self Assessment

Fill in the blanks:

1. Brand loyalty is ..... in consumers due to product distinction.
2. Every firm has ..... over their brand.
3. Price rigidity is another feature of .....
4. Price is found to be ..... in Oligopolistic market.

**Three Basic Features of the Oligopolistic Market Structure**

(i) **Interdependence among the Firms:** Mutual interdependence of firms in decision-making is an important feature. Why interdependence? Because when the number of participants is very less, any change in the production or price by a firm directly affects the profits of other firms. Therefore, their reactions would either be in the form of change in price and production or in the form of intensive publicity in order to attract more buyers.

Therefore, while deciding over quantity of production and price not only a firm has to consider the demand curve but also has to consider the reactions of the competing firms.

(ii) **Advertising and Selling Costs:** Due to the mutual interdependence of the firms of an Oligopolistic market, the firms have to adopt various defoliation related aggressive and defensive techniques so that they can capture the maximum market share and can retain their current position in the market. Therefore, they have to spend on publicity and sale incentive. This is why publicity and sales costs hold an important place in the Oligopolistic market. To note, a firm does not keep reducing the price of its commodities rather they keep competing over non-price basis. Because price reduction results into price war between the firms, hence resulting in the ouster of few firms.

(iii) **Group Behaviour:** The basis of Oligopoly is group behaviour and not gathering or personal behaviour. There is no general accepted basis of group behaviour. Will the members of the group agree to boost for their general rights or should they fight for their own personal rights? Is there a leader of that group? If yes, then how does he manage to make the others follow him? Questions like these are important to determine the theory of group behaviour. But one thing is for sure. Every oligopolistic industry keeps vigilance over other oligopolistic industries' business behaviour. Based upon their behaviour and reactions, they plan everything.

The basic difference between complete competition, monopoly, monopolist competition and Oligopoly is that the decisions of the oligopolistic firms in the Oligopolistic market affect the other participants in the market, whereas this feature is missing in other forms of market.



*Did u know?* Price rigidity exists in Oligopolistic market.

## 15.2 Behaviour of Oligopolistic Firms and Other Market Structures

Firms in the Oligopolistic firms get affected by the behaviour of other firms in the market. Therefore, the firms adopt a strategic way of conduct. In other words, they keep a crystal clear idea of the effects their decisions would cause over other firms and how would they react. Whereas, in competitive and monopolistic competition have a non-strategic way of conduct which means that their decisions are completely based upon their costs and demand curves and they do not have to anticipate the reactions of their competitors. Based on this, even the monopoly market adopts the non-strategic way as they do not have to face any competition.

### Strategic and non-strategic conduct

*Strategic conduct is the one in which a firm considers and anticipates the behaviour and reaction of its competitor firms while deciding over the price and production. Oligopolistic market is a good example of this. Non-strategic conduct refers to the one in which a firm does not have to worry about the reaction and behaviour of its competitors and has to only consider its costs and demand curves while deciding over price and production.*

### Self Assessment

#### Multiple choice questions:

5. A firm can achieve ..... by coalition through increase in price.
  - (a) monopolistic profits
  - (b) profit
  - (c) loss
  - (d) none of these
6. Price rigidity means no ..... in the prices by the firms.
  - (a) change
  - (b) increase
  - (c) reduction
  - (d) none of these
7. Oligopolistic is the form of market .....
  - (a) lowest
  - (b) highest
  - (c) competent
  - (d) none of these
8. Deciding over production and price in the absence of profit maximisation as a motive is .....
  - (a) hard
  - (b) very hard
  - (c) easy
  - (d) very easy

### 15.3 Classification of Oligopoly

The classification of oligopoly can be defined as –

1. **Perfect or Imperfect Oligopoly:** In Oligopoly, firms produce homogeneous products. It is also known as Pure Oligopoly. On the other hand, in incomplete or differential oligopoly in which all the firms produce differential yet close substitute products.
2. **Open or Closed Oligopoly:** Open Oligopoly is the condition when there is no restriction or barrier to the entry of firms. Firms are free to enter the industry. But in closed oligopoly, firms have certain restrictions over entry in the industry. These restrictions could be technical, legal or of any other type.
3. **Partial or Full Oligopoly:** Partial Oligopoly is that condition in which a dominant firm exists. This firm is known as the Price Leader. This Dominant firm and the price head decide the prices and rest of the firms have to accept the prices. Full Oligopoly is the condition in which there is no Dominant or Price head in the industry.
4. **Collusive or Non-collusive Oligopoly:** In Collusive Oligopoly, firms support each other while deciding over the prices. They adopt one single policy and do not compete with each other. But in non-collusive Oligopoly, firms decide over the prices independently and also they compete with each other.



Task

Write down your thoughts over “Classification of Oligopoly”.

### 15.4 Why Bigness? Or What Causes the Emergence of Oligopoly?

There are so many reasons to emergency of some big firms in oligopoly market. Some factors are natural but some are created by the firms themselves.

#### Natural Causes

- (a) **Economies of Scale:** The theory of `Labour Division is applied to factory productions which means the process of production is divided into parts and each part is allocated to the most efficient labour. According to **Adam Smith**, labour division depends upon the extent of the market. Firms having a big demand in the market need to produce on a large scale. In order to produce on a large scale, labour division takes place. The larger is the scale of production, the lesser is per unit average due to increase-decrease loss. This is known as Economies of Scale and this is how firms increase their scale of production.
- (b) **Fixed Costs:** The cost of introducing a product in the market is very high. To outline a new product and to introduce it in the market is not an easy task. The Sunk Cost of a new product and its marketing in a prevalent market is very high. Sunk cost is the cost which cannot be recovered. In the present time, products produced from latest technology have a huge production cost. The big firms which have a detailed sale scale and per unit production is less; their price advantage is higher in comparison with small firms.
- (c) **Economies of Scope:** To enter a market, to introduce a product and to make the anticipated consumers aware of the product is a costly affair. The costs of these activities are very high. These costs cannot be recovered by sales of small firms. If these firms increase the prices of their commodities, that might result into decrease in sales and might hinder their existence in the market

as well. Only big firms who have a diversified range of products can bear the non-production costs. Due to their comprehensive size (as compared to any specific plant), these firms can make savings in their sectors. Because of the savings in their sectors, big firms are capable of dividing the costs incurred by non-production amongst the products and services that they produce. Therefore, their cost curve is always inclined downwards. This is another reason for the emergence of Oligopolistic structure.

## Self Assessment

State whether the following statements are True/False:

9. The basis of Oligopoly is group-behaviour and not gathering or personal behaviour.
10. Group-behaviour does not have an established base.
11. An Oligopolistic does analyze the business behaviour of other participants.
12. According to **Adam Smith**, labour division depends on the size of the market.

## Firm-Created Causes

As mentioned above, the behaviour of Oligopolistic firms is very strategic. Though there is a trend of decrease of firms in the industry, however, the firms which survive (Survivors) have an increase in their average size. This because of the strategic practices, which the surviving firms undertake. Either the big firms purchase small firms or a merger takes. This process increases the size and market share of small firms and also let them earn more profits being an Oligopolistic. The mutual competition also decreases.

## 15.5 Summary

- **Lipsey** has described the Oligopolistic form of market as, "Oligopoly is the theory of an incomplete competition between firms. It is related to an industry in which there are only a few participants. Every firm has a market value of such magnitude that it stops it from becoming price-acceptor, but each firm has to face such inter-firm competitors which stop it from believing that the demand in the entire market is for that particular firm."

## 15.6 Keywords

- **Oligopoly:** Sway of firms in the industry
- **Homogeneous:** Equal shaped
- **Excess capacity:** Having high capacity

## 15.7 Review Questions

1. What do you understand by oligopoly? Explain.
2. Explain the features of oligopoly.
3. What are the reasons for the emergence of oligopoly?
4. What do you understand by collusive and non-collusive oligopoly?

Notes

**Answers: Self Assessment**

- |             |             |              |             |
|-------------|-------------|--------------|-------------|
| 1. Creation | 2. Monopoly | 3. Oligopoly | 4. Rigidity |
| 5. (a)      | 6. (a)      | 7. (b)       | 8. (b)      |
| 9. True     | 10. True    | 11. False    | 12. False   |

**15.8 Further Readings**



*Books*

1. **Microeconomics**—*David Bosanko and Ronald Brutigame, Wiley India, 2011, PBK, 4th Edition.*
2. **Microeconomics**—*Shipra Mukhopadhyay, Annie Books, 2011.*
3. **Microeconomics: An advanced treatise**—*S.P.S Chauhan, PHI Learning.*

## Unit-16: Duopoly and Oligopoly: Cournot Model and Kinked Demand Curve

---

### CONTENTS

Objectives

Introduction

- 16.1 Meaning of Duopoly
- 16.2 The Cournot Model
- 16.3 Price Determination Under Oligopoly
- 16.4 Summary
- 16.5 Keywords
- 16.6 Review Questions
- 16.7 Further Readings

### Objectives

After studying this unit, students will be able to:

- Know the meaning of Duopoly.
- Studying the Cournot Model.
- Know price determination under oligopoly.
- Know the changes in cost.

### Introduction

To know the characteristics of oligopoly, we do further the study of price and production determination by monopolistic firms. But we limit our analysis from the non-collusive monopoly model of Sweezy and price determination and collusive monopoly model of Cartel.

### 16.1 Meaning of Duopoly

The duopoly is the unique part of monopoly theory where there are only two sellers. Both the sellers are independent and there is no agreement between both of them. However, there is no agreement between them but if one changes his price and production, the other will be affected and it is possible to create a change of reactions. But there might be possible that one seller thinks that the change does not affect other and put the changes in his price. On the other hand, if the seller thinks about

**Notes**

the reaction behaviour of these changes, then he must think about direct and indirect pricing. And it also is possible to change in the quantity of product or its price does not affect the policy of opponent seller. So duopoly can be described by taking mutual dependency or avoiding this mutual dependency. The **Cournot Edgeworth** solution is already have which avoid this mutual dependency and this mutual dependency is taken in Chamberlain solution.

### 16.2 The Cournot Model

In 1838, economist from France **A. A. Cournot** proposed this duopoly solution. He gave example by two firms A and B as well as the lake of mineral water.

**Assumptions:** The **Cournot** model is based on these assumptions:

1. There are two independent sellers.
2. They produce a homogenous product which is mineral water.
3. The consumption of total production is essential because the product is destructive and non-volatile.
4. The number of buyers is more.
5. Every consumer knows about the market demand curve of the product.
6. The cost of production is assumed as zero.
7. Both the firms have equal cost and equal demand.
8. Every seller decides that what he wants to produce and sell in a period of time.
9. But from each, they do not know anything about the production of others.
10. Also, both the sellers assume constant to their opponent's production.

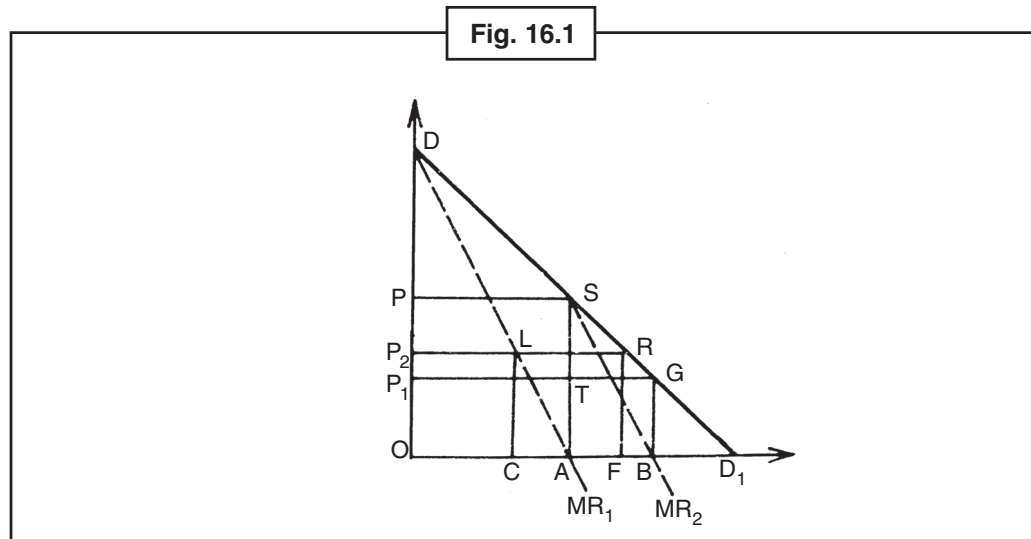

11. From each of them, no one has fixed the price of his product but accept the market demand price on which product sells.
12. The entry of new firm is closed.
13. Every seller's dream is to get maximum and pure profit and revenue. On these given assumptions, suppose that two firms A and B extract water from waterfall of mineral water. Their market demand curve is  $DD_1$  and marginal revenue curve is  $MR_1$  as shown in Fig. 16.1. The marginal cost of A and

B is zero and it matches with parallel axis. Suppose that firm A is a single manufacturer. In this case when its  $MR_1$  curve is equal to MC curve (parallel axis) on point A then it produces and sells OA ( $= \frac{1}{2} OD_1$ ) quantity. It takes monopoly price AS ( $= OP$ ) and gets monopoly profit OASP. Now firm B comes into market and hope that firm A will not change its production level OA. So, it takes the part  $SD_1$  to its demand curve. Its marginal revenue curve is  $MR_2$  which intersects its MC curve on point B. So it sells AB quantity ( $= \frac{1}{2} OD_1 = BD_1$ ) on BG ( $OP_1$ ) price and hope to get profit as BGTA.

Notes



Notes The duopoly is the unique part of monopoly theory where there are only two sellers.

Firm A knows that the price is decreased from  $OP$  to  $OP_1$  as B comes in market. So the assumed profit falls as  $OP_1TA$ . In this stage, it tries to adjust its price and production. To fix that firm B will sell the AB ( $= BD_1$ ) quantity, firm A sells  $\frac{1}{2} OB$ . Thus the decrease in quantity from OA ( $= \frac{1}{2} OD_1$ ) to  $\frac{1}{2} OB$  rises the price which is not shown to simplify the figure. B reacts as the production of A decreases and increased its production to  $\frac{1}{2} (OD_1 - \frac{1}{2} OB)$  and by this price drops. Thus the price increases due to decrease in production by firm A and the production increment by B by which price increases; the **equilibrium price** would be  $OP_2$ . In this price, the total production of mineral water is OF, which equally differentiate in both firms. Each sells  $\frac{1}{3}$  parts of market demand means firm A sells OC and firm B sells CF. In this price the profit of A is  $OCLP_2 =$  profit of B  $CFRL$ .

It is clear that both firms sell  $\frac{2}{3}$  of total production  $OD_1$ . If number of firms is  $n$  then rate of production will multiple of  $n/n + 1$ . The total production of both the firm A and B is  $2/2 + 1 = 2/3$ . So the total production of A + B is  $OD_1 (1 - 1/2 + 1/4 - 1/8 + 1/16 - 1/32 + 1/64\dots) = 2/3 OD_1 = OF$ .

The duopoly solution of **Cournot** is tally with perfect competition solution. The duopoly firms A and B take price  $OP_2$  and sell quantity OF in equilibrium state. Under perfect competition, total production will be  $OD_1$  in zero price. Price is zero because marginal cost is zero. When MR curve intersects parallel axis MC curve on point A then price will be zero. The total production  $OD_1$  will equally distribute between A and B firm:  $OD_1 = OA + AD_1$ .  $OA = AD_1$  In **Cournot** solution,  $OP_2$  price is greater than marginal cost and zero price and perfect competitive production OF is less than  $OD_1$ . But in **Cournot** solution, production OF is greater than monopoly production OA but price  $OP_2$  is less than monopoly price OP. Mathematically, in **Cournot** solution the production is  $\frac{4}{3}$  of monopoly production and  $\frac{2}{3}$  of perfect competition.

**Conclusion:** The **Cournot** model could increase from two firms. When more firms are entered in oligopoly market then the price and production of industry will go  $OD_1$  for perfect competitive production and price will go to zero.

## Self Assessment

### Fill in the blanks:

1. The duopoly is the unique part of monopoly theory where there are only ..... sellers.
2. According to **Cournot** model, the cost of production is .....
3. Every consumer knows about the market ..... of the product.

## Cournot Model in Terms of Reaction Curves

As the assumption of the basic model of **Cournot**, the economists have given a better solution by reaction curves. This definition takes an extra assumption that duopoly firms react from its competitive firm irrespective to production tactics.



**Notes**

So, by supposing this that if A will produce then B will not react or vice versa the output reaction curves can be drawn on vertical axis for production of A and on horizontal axis for production of B. In Fig. 16.2, the reaction curve A is AL and reaction curve for B is RB. Let's assume firm A produce OG. By fixing this that A will not change OG, firm B reacts by producing OH. Then A reacts by assuming that B will not react in its production OH and produces OE. Again B reacts and produces OF. Now we see that by reacting A on B, the production of A decreases and the reaction on B over A increases its production. This reaction occurs till both reach on Cournot point C where both A and B produce similar production. The production of A is equal to OM while production of B is equal to OF. This conclusion comes on that time when we move downward from right to above in Fig. 16.2. Thus, the analysis of reaction curve model is affected to get **Cournot** model.

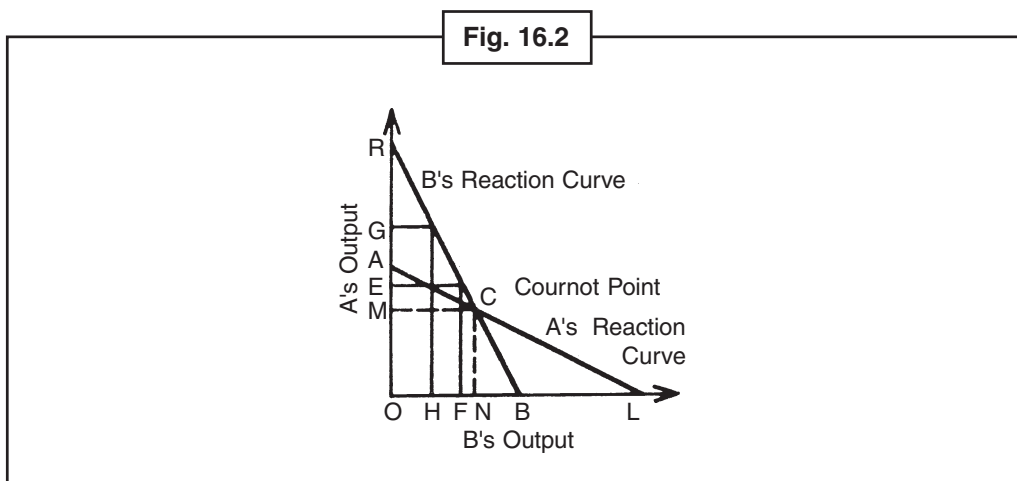

**Its Criticism**

These are the following criticisms of **Cournot** model –

- (1) The main defect in **Cournot** model is every seller assumes that the supply of their opponent is stable, while he saw it changes every time. In 1883, one French mathematician **Joseph Bertrand** criticized **Cournot** that seller will make his price less than B for those customers who by passed to B earlier and this less price strategy will continue till price comes on zero. Thus **Bertrand** proposed that there is no limit of falling prices because every producer can double his product and set less price irrespective to his opponent. Thus, the price would come in competitive level in long run.
- (2) This is **stable model** because it does not give any idea when a firm reacts and adjusted its production as per another firm's tactics.
- (3) The **Cournot** solution is not real because it shows **zero** production cost.
- (4) This is closed model because it neglects the entry of other firms.
- (5) This assumption is also not real that every dupololist works without knowing another. In fact this model is like 'not working' model.
- (6) According to **Marshall**, "The **Cournot** model is unable to give universal solution." This is because to find a duopoly market where every dupololist works independently and there is no parameter of production process.

### 16.3 Price Determination Under Oligopoly

To know the characteristics of oligopoly, we do further the study of price and production determination by monopolistic firms. But we limit our analysis from the non-collusive monopoly model of **Sweezy** and price determination and collusive monopoly model of **Cartel**.

#### 1. The Sweezy Model of Kinked Demand Curve (Rigid Prices)

In a column in 1939, **Prof. Sweezy** proposed Kinked Demand Curve analysis for describing price constant in monopoly market. **Sweezy** thinks that if monopoly firm decreases its price, then in reaction, its opponents will cut their prices accordingly and regularly in fearing of losing the customer. Thus, the firms which cut their price will not increase its demand. So this portion of demand curve is less elastic. In contrast, if monopoly firms increase their price, then the opponent will not change their price. Thus, the demand of that product would be less. So this portion of demand curve is respectively more elastic. In both the conditions, kinked is found in the demand curve of monopoly firm which shows price stability.



*Did u know?* The **Cournot** solution is not real because it gives zero cost in production.

#### Its Assumptions

The kinked demand curve theory of price stability is based on following assumptions –

- (1) There are some firms in monopoly industry.
- (2) The product of a firm is nearly substituted by other firms.
- (3) Product is of single quality. There is no differentiation of product.
- (4) No marketing cost.
- (5) There is a fixed and current market price of product which satisfies all the sellers.
- (6) The behaviour of every seller depends upon their opponents.
- (7) If any seller tries to increase their selling by decreasing the product price, then all sellers will follow and this technique will not fulfill the primary seller's desire.
- (8) If he increases the price then nobody will follow him and fulfill the consumer's demand with their existing price.
- (9) The marginal cost curve crosses in the middle of kinked part of marginal revenue curve. So the change in marginal cost is not affected to production and price.

#### Self Assessments

##### Multiple choice questions:

4. According to **Marshall**, **Cournot** model does not give solution to ..... .  
 (a) possible            (b) impossible            (c) tried            (d) none of these
5. Reaction curve analysis is helpful to **Cournot** model's stable and ..... equilibrium.  
 (a) unique            (b) curve            (c) cost            (d) marginal
6. The region of monopoly of **Prof. Mculp** is ..... .  
 (a) wide            (b) two            (c) four            (d) none of these
7. As per criticism of **Cournot** model, the solution is ..... .  
 (a) unreal            (b) real            (c) zero            (d) none of these

Notes

**The Model**

By these assumptions, the relation between price and production in monopoly market is described in Fig. 16.3. In the figure, KPD is a kinked demand curve and  $OP_0$  is the current price of a seller in oligopoly market. For quantity OR, starting from P for current price  $OP_0$  and above, the price increment will decrease the selling of that product because it does not hope that its opponent will follow this tactic. The reason behind this is that the KP part of kinked demand curve is elastic and KA part of MR curve is positive. So if price increases then its total revenue and profit will decrease as well as total selling too.

On the other hand, if seller drops its price by  $OP_0 (= P)$  then its opponent will also follow him. However, its sell will increase but the profit will be low. The reason behind this is the PD of kinked demand curve below P is less elastic and the below part of R of marginal revenue curve is negative. Thus seller will not get any profit, however, it decreases or increases the price. It will be on current market price  $OP_0$  which is rigid.

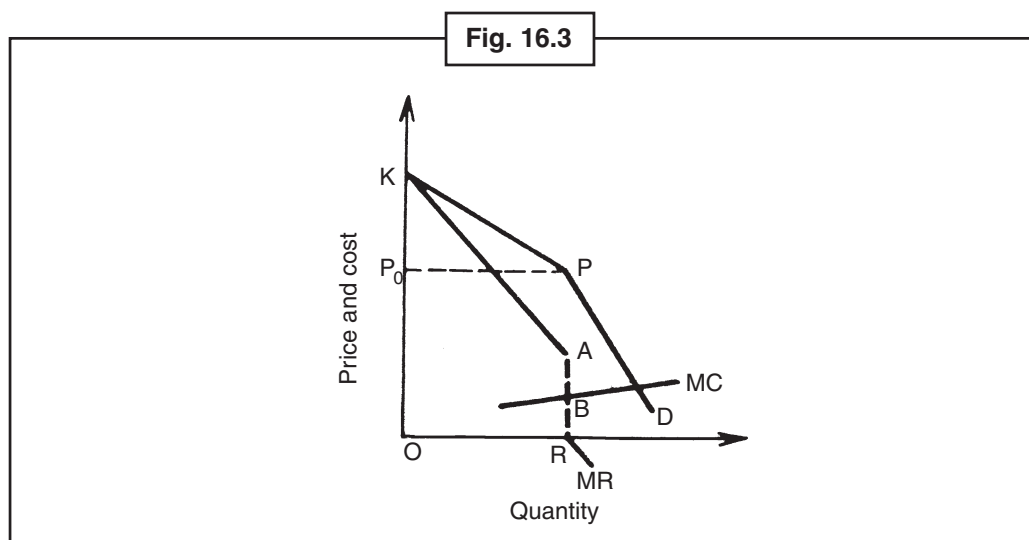

To know the process of kinked demand curve, now we analyze the effect of changes in demand stage and cost in pricing in oligopoly market.

**Changes in Costs**—In oligopoly stage, analysis of kinked demand curve, the current price is not affected by change in fixed cost. Suppose that the cost of production drops by this new  $MC_1$  curve goes into right side  $MC_1$  which is shown in Fig. 16.4. It intersects in difference AB to MR curve by which profit maximization product is OR which can sell on  $OP_0$  price. It must be known that, however, price drops, new MC curve will cut MR curve in difference, because as price falls, the difference AB widens by two reasons - (i) as soon as cost drops, the KP part of demand curve will more elastic because it defines that the increment in price will not follow by their opponent and their sell will drop (ii) By dropping of cost, PD part of kinked curve will be non-elastic because it defines that decreasing of price will follow by all sellers.

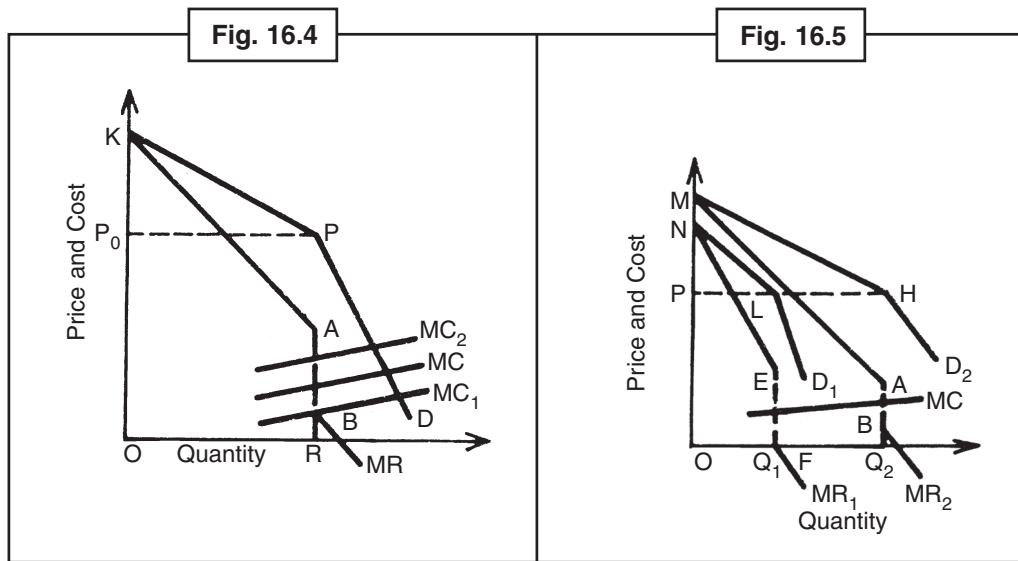

So, there is a right angle found by angle KPD on point P and difference increases by this no MC curve cuts under MR below on point A. The result is that the production  $OR$  remains same on point  $OP_0$  and monopoly sellers get more profit.

If production cost increases then the marginal cost curve goes on  $MC_2$  on old MC curve. Price will be stable until high MC curve intersects MR curve under point A. Yes, if cost increases then it will not be permanent and if MC curve goes above to A then it will intersect MR curve on KA part and by this, low quantity will cost more. Result is in oligopoly, price can be stable when changes cost until MR curve cuts to MC curve. But the stability in price is more found in less cost than more cost products.

**Changes in Demand** – Now we describe the changes in demand with price stability by the help of Fig. 16.5.  $D_2$  is original demand curve,  $MR_2$  is marginal revenue curve and MC is marginal revenue curve. Suppose that the demand decreases which is reflected by  $D_1$  curve and  $MR_1$  is its marginal revenue curve. When demand decreases then a seller cuts his price and opponents follow this tactict. By this the new demand curve  $LD_1$  becomes more elastic than  $HD_2$  of old demand curve. This will reach angle L to right angle. This results that the difference between EF of  $MR_1$  will be more wider than AB of  $MR_2$  curve. Thus it reflects that in oligopoly industry, price is stable, however, the demand is low. Since the level of both demand curves kink H and L is equal, so after falling of demand, price remains same as OP. But the production level decreases from  $OQ_1$  to  $OQ_2$ .



**Task** Give your opinion in kinked demand curve model of **Sweezy**.

To make opposite this situation by increase in demand  $D_1$ ,  $MR_1$  is original demand and marginal revenue curve, while  $D_2$  and  $MR_2$  are high demand and marginal revenue curve respectively. OP remains same in it, but production increases from  $OQ_1$  to  $OQ_2$ . Price is stable until MC curve cuts MR curve. When demand increases then a seller wants to increase his price and hopes that other sellers will follow him. Due to this, the upper portion of new demand curve MH will be elastic rather than old demand curve part NL. So there is a right angle created on H. The difference of AB is less in  $MR_2$  curve and MC curve intersects  $MR_2$ , which shows high price. But if crosses from marginal cost curve  $MR_2$  then price will be stable.

Notes

### Reasons for Price Stability

There are various reasons for price stability in some oligopolistic markets:

**First**, it might be possible for the sellers of oligopolistic market, that by experience they know that price war is not better for them, so they prefer the price stability.

**Second**, it might be possible that they are not satisfied with current prices, production and profits and not want to step in uncertainty.

**Third**, it might be possible that to protect incoming of firms in market, they will prefer price stability.

**Fourth**, Sellers can practice to increase their price rather than to decrease. It might be possible that they prefer non-price competition than price war.

**Fifth**, after using a big money in advertising, they do not prefer to increase their price, so they will prefer to stay with current price of product.

**Sixth**, if there is a new price due to any agreement then no seller will leave this agreement because if he rises the price, others will follow and he can drop in uncertainty and become unsafe.

**Last**, Kinked demand curve comes brings stability in oligopolistic market.

### Self Assessment

State whether the following statements are True/False:

8. Every seller's behaviour depends upon his opponents.
9. Kinked demand curve brings price stability in oligopolistic market.
10. Sellers can practice to increase their price rather than to decrease.
11. Selling not always occurs on tagged price.
12. The kinked demand curve is based on two assumptions.

### Its Shortcomings

But in oligopolistic price determination, kinked demand curve is not free from demerits –

- (1) If we accept on each assumption, then it is not possible that the difference in marginal revenue curve is so big to enter marginal cost curve. Price will be non-stable if demand or cost decreases.
- (2) According to **Stigler**, the main reason behind this is that "Theory does not explain those prices which are changed, why again retains and make a new kink slowly." For example, in Fig. 16.4 kink is made on P because  $OP_0$  is current price. But this theory does not explain that how  $OP_0$  was established.
- (3) Price stability can be imaginary because it is not based on real behaviour of market. Selling not always occur on tagged price. Generally, give some commission or rebate, sellers sell product with some low prices. The oligopolistic seller can set fixed price, but by decreasing quantity of product or quality. So price stability is illusionistic.
- (4) Again, there are some products which show stable price but it is quite impossible to collect their price range in numbers. So it is quite doubtful that price stability happens in oligopoly.
- (5) Kinked demand curve is based on two assumptions. First, all other firms will follow the price cutting and second, they do not follow price rising. **Stigler** has proved this that in inflationary situation, the price rise in inputs is not in a single firm but it happens with industry. So all firms having similar costs will follow each other. According to **Stigler**, "In historical base, a firm cannot believe that price increment is not followed by opponents and price defects will be handled accordingly."

## 16.4 Summary

Notes

- All the analysis of kinked demand curve expresses that when all sellers decrease their price then there is price stability in oligopolistic market. Generally, changes in demand and cost brings price stability until MC curve intersects MR curve in its lower part. But price hike is found in high demand and high cost.

## 16.5 Keywords

- **Shortcomings:** Demerits
- **Stability:** Rigidity (in price)

## 16.6 Review Questions

1. What do you mean by duopoly? Explain it.
2. What do you understand by **Cournot model**?
3. Write some points on 'Price Determination in Oligopoly'.

### Answers: Self Assessment

- |           |          |                 |          |
|-----------|----------|-----------------|----------|
| 1. Seller | 2. Zero  | 3. Demand Curve | 4. (b)   |
| 5. (a)    | 6. (a)   | 7. (a)          | 8. True  |
| 9. False  | 10. True | 11. True        | 12. True |

## 16.7 Further Readings



Books

1. **Microeconomics**—*Frank Cowbell, Oxford University Press, 2007.*
2. **Microeconomics**—*Shipra Mukhopadhyay, Annie Books, 2011.*
3. **Microeconomics: An Advance Treatise**—*S.P.S. Chauhan, PHI Learning.*

## Unit-17: Bain's Limit Pricing Theory

### CONTENTS

Objectives

Introduction

17.1 Limit Price Theory of Bain

17.2 Its Criticisms

17.3 Summary

17.4 Keywords

17.5 Review Questions

17.6 Further Readings

### Objectives

After studying this unit, students will be able to:

- Know Limit Price Theory.
- Understand Bain's Model.
- Know Product Differentiation.

### Introduction

**V.S. Bain** is the first economist who proposed Limit Price Determination Theory in one of his articles. Then he revised this theory in his first book *Barriers to New Competition* in 1956 and in 1959 in his second book *Industrial Organization*. He represented that collusion firms can be afraid of probable entrance of other firms. They cannot have substitutes of their commodities in definite range. But if price is fixed at high level, then probably opposite firms are afraid of entrance. They can enter in industry on attracting high profits. In this condition, the price is always high which is called Price Limit. Established firms can charge this price without attracting entrance of other firms.

In his *Barriers to New Competition*, **Bain** has developed limit price determination theory for stopping the entrance of new firms by giving more elaborated certified statement. In his book *Industrial Organization*, he has given better statement of his theory. We are mentioning the **Bain's** Theory which has been described in his books.

### 17.1 Limit Price Theory of Bain

**Bain** has developed Limit Price Determination Theory to stop the entrance of new firms in a short authorized industry in his book *Barriers to New Competition* (1959). Joining with collusion, limit price is fixed by a group of firms, which is the highest general price. It is the price which can prevent the

entry of other firms in the established firm industry without motivating it. This price can be less than the profit maximum price in short duration and will depend on relative cost of firms of inside and outside the group and demand conditions in industry. **Bain** tells the limit price is upper maximum price than the competitor price, which is fixed by established firms. These price works as the barrier of entrance of new firms. The profits obtained by upper established firms of new entrants in the industry are the barriers of entrance.

### Self Assessment

#### Fill in the blanks:

1. .... are done for price and production in long-term.
2. .... are established least right in industry.
3. Other firms in group follow ..... price policy.
4. .... is effective in established firms.

### Its Assumptions

**Bain's** Model depends on following assumptions –

1. Adjustments are done for price and production in long-term.
2. Least Right firms are established in the industry.
3. Demand curve for production of industry is not affected by the entrance of new firms or price adjustments by least right firms.
4. Collusion is potential among established firms. This trick pact depends on chief leader.
5. Other firms follow unification price policy in group.
6. Lead firm fixes limit price or entry barrier price, under which entry cannot be done.
7. There is only one probable entrant firm whose investments are less in comparison to other probable entrants.



Notes

Joining with collusion, limit price is fixed by a group of firms, which is the highest general price.

### Bain Model

**Bain** initiates his limit price determination model by the conditions of entrance. It is premium or per cents by which established firms can raise price than the competitor price without attracting the entrance of new firms in group.

Symbolically, condition of entrance,

$$E = \frac{P_L - P_C}{P_C} \text{ and } P_L = P_C (1 + E)$$

Where  $P_L$  is limit price and  $P_C$  is competitor price. Formula shows that  $E$  is the premium which established firms obtain limit price ( $P_L$ ) without attracting the entrance of new firms. When established firms fix  $P_L$  above  $P_C$ , they earn more than general profit because competitor price is  $P_C = LAC$  in which general profit is also included. Therefore,  $E$  is the end limit above competitor price,  $P_C$  (or premium), which established firms earn fixing the high limit price ( $P_L$ ).



**Notes**

According to **Bain**, time duration included in situation of entrance is long in which a special range of changed condition of demand, procedure prices etc. is merged. This time duration can be of range of 5-10 years. More the time taken by a firm to establish, less will be the fear of entrance. Therefore, the gap between limit price ( $P_L$ ) and competitor price ( $P_C$ ) will be more. This gap is known as **Entry Gap** or **Entry Barrier**.

To understand basic relation between entry barriers and limit price determination, analysis of **Bain** has distributed between Sources of Entry Barriers and Determination of Limit Prices.

**Sources of Entry Barriers and Determination of Limit Prices**

**Bain** mentions four main sources of entry barriers: Product Differentiation, Economies of Scale, Absolute Cost Advantages and more amount of money. **Bain** includes more amount of money in absolute cost advantages in his book *Industrial Organization*. So we are also not mentioning it differently.

**Product Differentiation**

Product differentiation gives the following ways of an entry barrier of a new firm:

1. Preferences for commodities of established firms.
2. Entrant firm needs to compete with established firms by advertising and big investment, which is far away from the economic budget of new firm.
3. There should be famous brand for established firms. In this way it can be difficult for new firm to compete with brand loyalty of customers.
4. If established firms have special sale ways to sale their commodities and have only one purchase agreement with wholesale buyers, then will face problems in establishing themselves in the new entrant firm market.

**Limit Price Determination** – Product differentiation as the entry barrier is explained in Fig. 17.1. Let the average costs be constant, the cost curve of LAC established firm is long-term average cost curve. The demand curve of group or the one which **Bain** called the best firm is DD.  $P_L$  is limit price fixed by this firm and  $Q_L$  is limit production. If firm takes  $P_L$  price then demand curve of possible entrant firm is  $D_E$  which does not allow it enter in least right market because  $D_E$  curve touches LAC on A point. That's why there is not any production level of firm which is more than the average production cost. If established firm raise the price to  $P_H$  which is entry inducing price so the production will fall to  $Q_1$ .

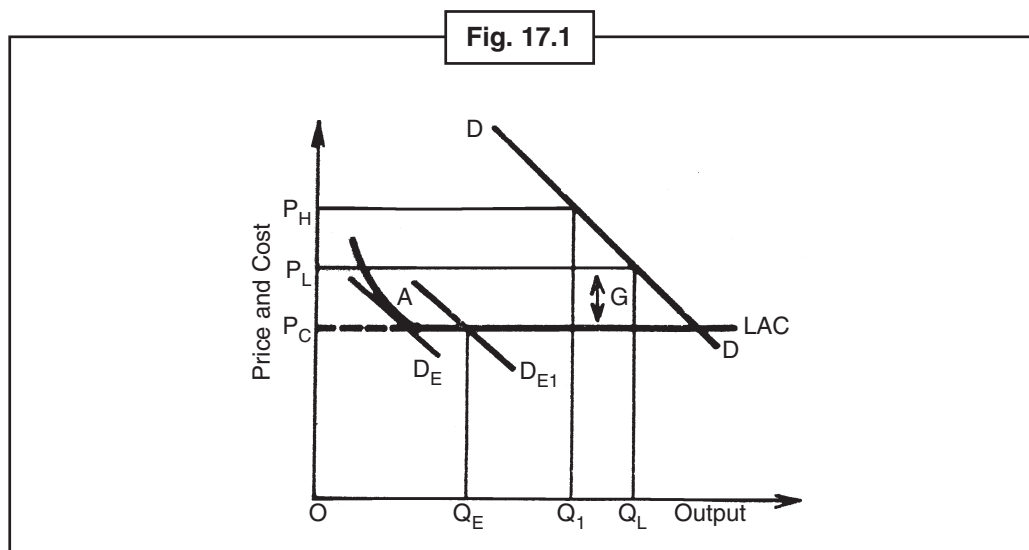

This inspired possible entrant firm to enter in the market and its demand curve rises to  $DE_1$ . New firm  $Q_E$  can produce quantity of any commodity at level. That amount of  $P_L$  price which is more than the  $P_C$  is the "height" of entry gap or entry barrier, which is denoted by  $G$  in the figure.

## Self Assessment

### Multiple choice questions:

5. **Bain** does his Limit Price Determination Model by the condition of entrance-
  - (a) initiate
  - (b) finish
  - (c) interactions
  - (d) none of these
6. According to **Bain**, the time duration included in entry situation is-
  - (a) Short
  - (b) Long
  - (c) Zero
  - (d) None of these
7. There is only one possible entrant firm, which has its costs in comparison to other possible entrants-
  - (a) more
  - (b) general
  - (c) less
  - (d) none of these
8. **Bain** mentions ..... main sources of Entry Barriers.
  - (a) two
  - (b) three
  - (c) five
  - (d) four

## Economies of Scale

Economies of scale are obtained by indivisibilities and specification in production and management and advantages from division of labour.  $R$  and  $D$  also affect marketing and distribution. Factors of economies of sales at level of limit price depend on the (a) expectations of entrant firm about reactions of established firm after the entry of possible entrant firm; and (b) expectations of established firms about the behaviour of entering firms.

**Bain** describes six possible expectations of possible entrant firms: (1) It expects from established firm that they keep the price constant after entry level. (2) It expects from established firms that they keep the production constant after entry level. (3) It expects from established firm that they let partly decrease their production and decrease their price but less than the above two possibilities. (4) It expects changes by the established firms so that they increase their before entry production. (5) It expects from the established firms that they decrease their production so that price raises higher than before entry level. (6) It expects the entry in industry without observing from any established firm because its plant is of very short scale so that established firms neither change their production nor change their market price.

From the above mentioned six possible expectations by possible entrant firm, **Bain** means third one most actual and possible. It is because entrant firm expects from established firm that they will partly decrease their production and will let partly fall the price. We will describe only two possible conditions.



*Did u know?* **Bain** initiates his limit price determination model with the conditions of entrance

Notes

1. Price Constant

In this condition, entrant firm expects constant price after entry level. Established firms permit entrant firms to fix the price of the quantity of commodity on given demand curve and plant scale of this firm. As a result, less will be the parts in total production of established firms.

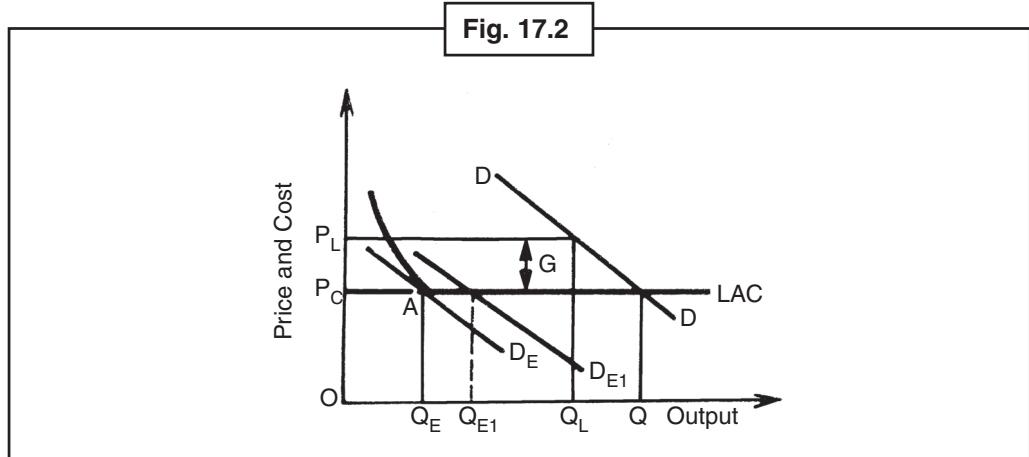

In this Fig. 17.2, it is shown that where  $DD$  is the demand curve of established firms which produce maximum production  $Q$  on scale of plants and sell it on competitor price. If established firms limit (entry barriers) price  $P_L$  then limit production is  $Q_L$ . They will sell  $QQ_1$  less quantity of production than the production on maximum scale of plant. This price will stop possible entrant firm to enter in the market when it is producing  $Q_E$  on minimum scale of plant. Demand curve of every firm is  $D_E$  which is parallel to market demand curve. This  $D_E$  curve touches on  $LAC$  curve point, so that level of any production of this firm is not more than the average cost. The gap  $G$  scale curve between  $P_L$  and  $P_C$  is its entry gap, which stops firm to enter in the market. Firm increases its scale plant so that established firms accommodate after permitting to sell the quantity of  $Q_E$  commodity, when its demand curve is  $DF_1$ . Decreases their buyer as the quantity of production sells by the firm.

2. Quality Constant

In this condition, entrant firm expects from the established firms that they retain their quantity of production constant before entry level. As it is shown in Fig. 17.3, established firms will produce limit

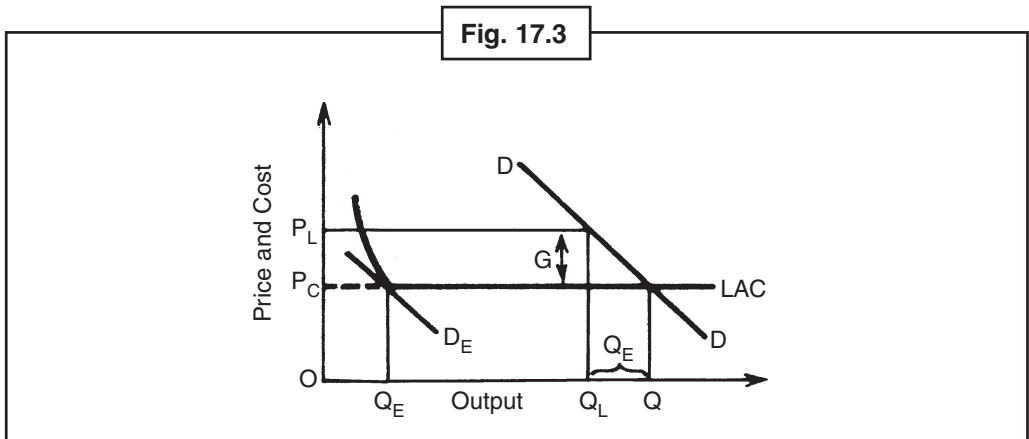

production  $Q_L$  and will sell them at limit price  $P_L$  on the given maximum scale of plant to stop the entry. Minimum and maximum plant produce possible entrant firm  $Q_E$  which fulfils its average production cost. Therefore,  $G$  is the **Scale Barrier** or entry gap for this firm. If established firms put their production on  $Q_L$  level and permit new firm to enter in the market and to sell their minimum maximum production  $Q_E$  then quantity production  $Q_E$  will increase in the market. It will be  $OQ = OQ_E + OQ_L$ . As a result, market price will fall little than competitor price  $P_C$  because established firms put their production before entry level and permit collected entrant firm production to reduce the price.



Task Give your opinion on Constant Price.

### Absolute Cost Advantages

According to **Bain**, absolute cost barrier can be obtained by – (1) utilising the best production technique by established firms by the secrecy or patent; (2) only one ownership of major collection of resources of established firms (3) unable to use the resources of necessary production by like capacity of obtaining the organizing services, labour means, constituents, etc. on the favourable conditions by the entrant firms which is obtained by established firms. (4) Working of established firms close to the sources of raw materials. (5) less favorable conditions of untidy sum for investment of entrant firm, which is imaged in the simple availability of sums in high effective interest or necessary quantities (6) less cost due to the production reaction of established firms and (7) less price of raw materials due to the only one purchase agreement with sale in large quantity or wholesaler by the established firms.

If established firms obtained these absolute cost advantages, then they work as barriers of the entry of new firms. If these costs are given then established firms can earn benefits on those prices which are less than the cost. Entry of firm can be terminated by lowering down the average production cost by fixing the limit price. It is shown in Fig. 17.4 that  $LAC$  is the long-term average cost curve of established firms. They fix limit price (or entry barrier price)  $P_L$  and demand curve  $DD$  fixes limit production  $Q_L$  on this price.  $LAC_E$  is the long-term average cost curve of possible entrant firm which is even higher than limit price  $P_L$ . Demand curve of this firm is  $D_E$  which is parallel to market demand curve  $DD$ . This demand curve  $D_E$  is situated under  $LAC_E$  of possible entrant firm, so that this firm cannot fulfill its

Fig. 17.4

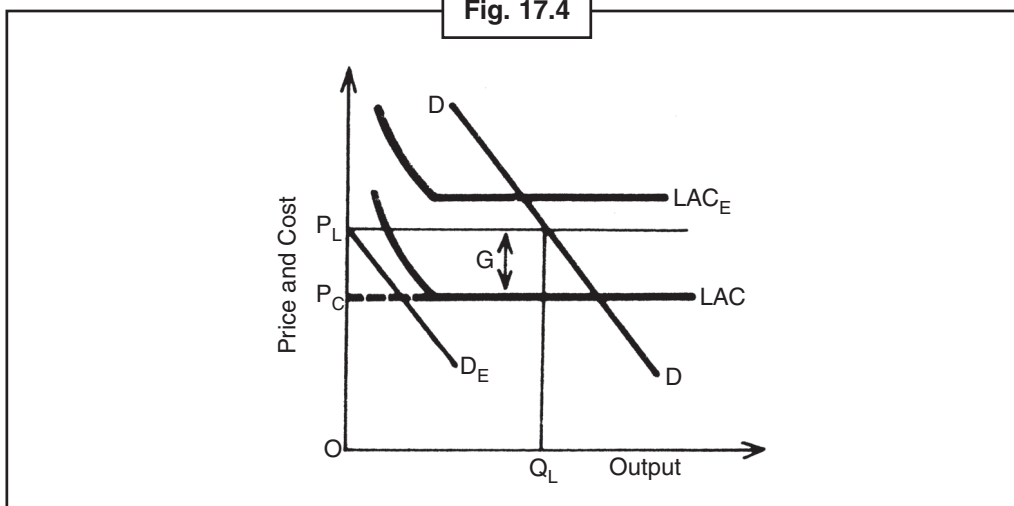

**Notes**

production cost on any production level. Therefore, this cannot earn benefit. In this way, it is impossible to this firm to enter in least right market.  $G$  is the entry gap which represents that established firms can fix limit price above its LAC without attracting entrance.

**Choice of Entry Barrier:** According to **Bain**, choice of entry barrier will depend on demand curve on entry limit price, shape of cost curve and expectations about their plans and expectations of entrant firm etc.

**Rate of Entry:** **Bain** emphasizes on market portion and speed of entry till the rate of entry of new entrant firms are possible. Faster the rate of entry, more flat will be the demand curve of least right industry above the entry limit price. Slower the rate of entry, lesser will be the importance of entry barrier. Market portion of entrant firm will be more in first condition and less will be in second condition.

**Self Assessment**

State whether the following statements are True/False:

9. **Bain** describes six possible expectations of possible entrant firm.
10. Entrant firm expects constant price on after entry level.
11. **Bain** understands only amount very expensive to obtain sums for new investment firms.
12. If three sources of entry barrier are taken together then limit price distribution becomes very complex.

**17.2 Its Criticisms**

**Bain** is the first economist who proposed limit price determination theory with the fear of entry. Instead of this, following limitations are found:

1. According to **Silberstein**, **Bain** did not make a general principle of price under least right conditions. He mainly established that which factor makes barriers in new competition in the industry mainly in some experienced studies.
2. According to **Koutsoyiannis**, the biggest fault of **Bain's** Model is that he focuses his studies on the entrance of new firms. He does not include takeover of firms, potency of diffusion by the established firms and cross entry in his studies.
3. **Bain** does not give exact to estimate or measure the rate of entry.
4. He does not explain the shape and benefits of entrant firm which can affect the fear of entry.
5. **Bain** only considers on entrant firm, where it is more fear of a big group in comparison to one or two entrant firms. Some nearby or similar firms can present more fear of entry because of technological closeness.
6. According to **Koutsoyiannis**, **Bain** has failed to see that product differentiation and economies of scale can increase the possibilities of entry.

**17.3 Summary**

- If three sources of entry barrier are taken together then limit price distribution becomes very complex. They can make strong each other or can dest may their effects. For example, can make large economy of scale and very high barrier of product determination entry as shown in Fig. 17.5, represents a big entry gap between high limit price  $P_H$  and competitor price  $P_C$ . Limit production  $Q_H$  is very less. Therefore, a big entry gap and less production conditions are obtained by the established firms. As a result, entry is terminated because entry barrier is very high.

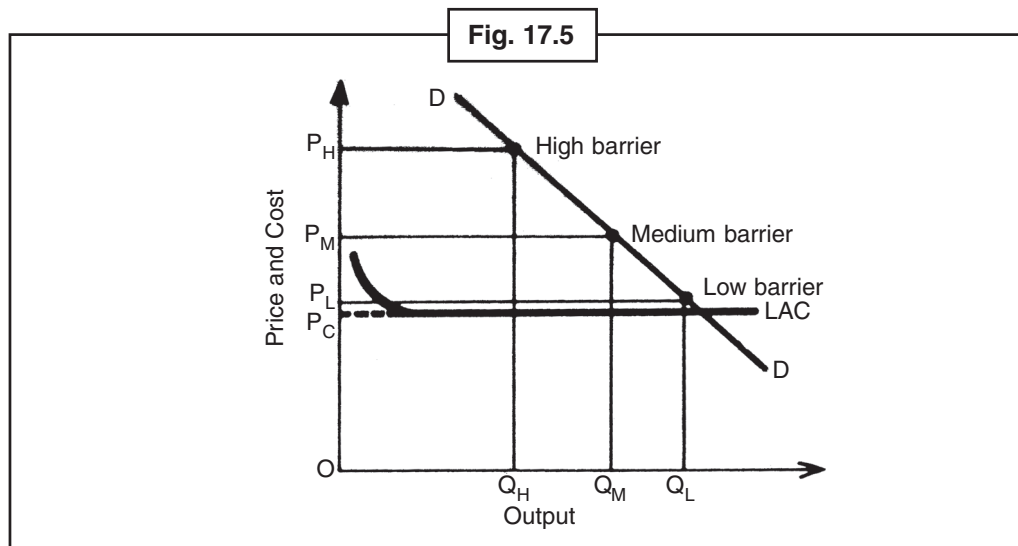

- On the other hand, a big possible entrant firm which has more economies of scale and more quantity of money is available and other cost benefits can soon entry compelled to put low barrier of established firm by the fear of soon entry. In this way, this firm can compelled to fix close limit price of established firm. This is shown in Fig. 17.5 and as a result entry gap  $P_L - P_C$  is very less limit production,  $Q_L$  is more.

## 17.4 Keywords

- **Barrier:** Fence, Difficulty
- **Entrant:** One who enters
- **Absolute Cost:** Complete cost
- **Rate of Entry:** Entry limit price

## 17.5 Review Questions

1. What is the **Bain's** Limit Price Theory? Explain.
2. Describe the **Bain** Model.
3. What do you mean by Product Differentiation?
4. Briefly explain 'Absolute Cost Advantage'.

## Answers: Self Assessment

- |                  |          |                |              |
|------------------|----------|----------------|--------------|
| 1. Accommodation | 2. Firms | 3. Unification | 4. Collusion |
| 5. (a)           | 6. (b)   | 7. (c)         | 8. (d)       |
| 9. True          | 10. True | 11. False      | 12. True     |

Notes

**17.6 Further Readings**



*Books*

1. **Microeconomics** – *Frank Cowbell, Oxford University Press, 2007.*
2. **Microeconomics** – *Shipra Mukhopadhyay, Annie Books, 2011.*
3. **Microeconomics: An Advanced Treatise** – *S.P.S. Chauhan, PHI Learning.*

## Unit-18: Profit Maximization and Full Cost Pricing Theories

### CONTENTS

Objectives

Introduction

18.1 Profit Maximization Theory

18.2 Theory of Full-Cost or Average Cost Pricing

18.3 Summary

18.4 Keywords

18.5 Review Questions

18.6 Further Readings

### Objectives

After studying this unit, students will be able to:

- Understand Full Cost Pricing Theories.
- Know Profit Maximization regarding perfect competition.
- Explain the criticisms of Full Cost Pricing Theories.
- Understand Theory of Average Cost Pricing.

### Introduction

The main objective of Firm's new-classical theory is Profit maximization. But more of experiences certificates indicate another objective of firm as sales maximization, production maximization, satisfaction maximization, utility maximization etc. Some of the theories will be analyzed in next chapter. This chapter analysis in the form of first research of Firm's new-classical theory, and Theory of Full-Cost or Average Cost Pricing by **Hall, Hich** and **Andruz**.

### 18.1 Profit Maximization Theory

The main objective is full cost pricing of any commercial firm in firm's new classical theory. Firm maximizes the profit when it satisfies two rules (1)  $MC = MR$  and (2) MR curve is cut by MC curve from bottom. The meaning of profit maximization is accurate profit which is greater than the average cost price of a product. This is the amount which is left with the producer after making the entire payment, it also contains the wages of management. In other words, it is Residual income, which is more from average profit. The condition of profit maximization of firm is described through—



**Notes**

Maximize  $\pi(Q)$

Where  $\pi(Q) = R(Q) - C(Q)$

Where  $\pi(Q)$  is profit,  $R(Q)$  arrival,  $C(Q)$  cost, and  $Q$  is the sold units of production.

Above description about rules and condition of profit maximization are applied to perfect competition firm and monopoly's firm.

**Its Assumptions**

The profit maximization theory is based upon following points:

1. The purpose of firm is profit maximization where the difference between arrival and cost profit.
2. Producer is owner of his own firm.
3. Interests and habits of consumers are constant.
4. The technologies of production are given.
5. Firm produces goods which are perfectly individual, separated and full of standardization.
6. Firm has the complete knowledge i.e. on how much cost and quantity of a product can be sold.
7. Firm has certain knowledge about demand and cost.
8. New firm can enter with long time period in industry. In short time, it is not possible.
9. Firm makes profit maximization in some time horizon.
10. Firm makes profit maximization in both short-term period and long-term period.

**Self Assessment**

**Fill in the blanks:**

1. The main objective of a firm's new classical theory is ..... maximization.
2. The mean of profit maximization is accurate profit which is ..... than the average cost pricing of product.
3. Firm ..... its profits.

**Profit Maximization Under Perfect Competition**

In perfect competition, the firm is one of the units from the more production unit. It can't influence the market price. It is the only Price Taker and Quality Adjuster. It takes decision of only of those products which are to be sold, so that it sells on market price. Therefore, the MR curve of firm is similar with AR curve under perfect competition. MR curve is parallel to x-axis. Because the price is decided by the market and the firm can sell the product on same price. In this way the firm is balanced when  $MC = MR = AR$  (price). The balance of firm's profit maximization is shown in Fig. 18.1, where MR curve cuts the MC curve at the first A point  $MC = MR$ . But it is not the point of profit maximization, because MC curve is sloping down from MR curve after "A". For a firm, the minimum production OM is not profitable because firm can take more advantage by doing more production from OM. But the firm stops the production when it reaches on  $OM_1$ .  $OM_1$  is the particular level of production where the both conditions of balancing are fulfilled. If firm wants to make more production from  $OM_1$  it will have to bear losses. Because maximum cost is increased from marginal arrival after balancing point B. So the firm maximizes the total profit in the cost of  $M_1B$  and the level of production  $OM_1$ .

Fig. 18.1

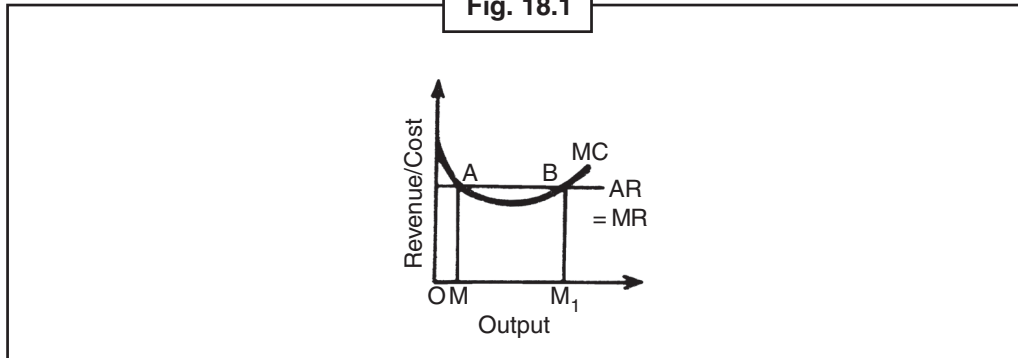

### Profit Maximization Under Monopoly

In the monopoly the firm itself is the seller (or producer) of a product. Therefore, its demand curve is sloping down from right. It is assumed that interests and habits are given. It is the price maker and it decides the maximum price and maximum profit. But it does not mean that it can fix both the price and quantity of production. If the firm makes the level of production, so its price is decided by marked demand. Or if it decides the price, so the production level will depend upon the demand of product by consumer. However, in any situation, the monopoly firms have only aims to maximize the profit. The condition of monopoly is (1)  $MR = MC < AR$  (price), and (2) MR curve is cut by MC curve from down.

Fig. 18.2

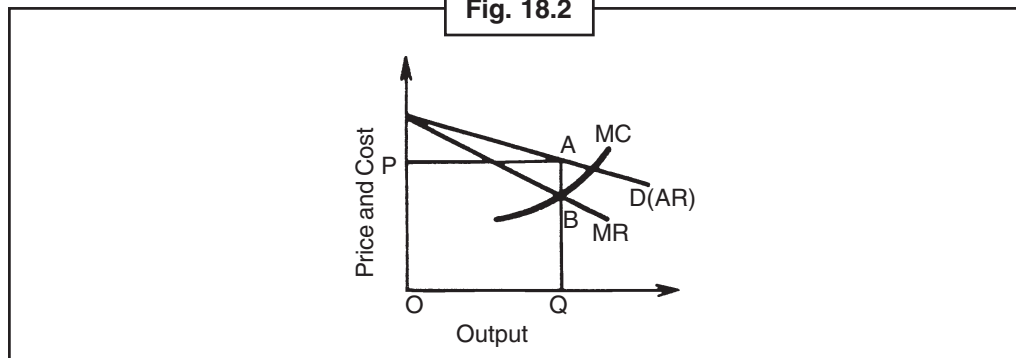

In the Fig.18.2, OQ is the production level for profit maximization and price is OP for profit maximization. If production is more than OQ, MR will be high from MC and the level of profit will be down. If cost and demand are same, firm will not get the motivation to grow the price and production, and then firm is balanced.



*Notes* The aim of a commercial firm is profit maximization in new-classical theory of a firm.

## Notes

**Criticisms of Profit Maximization Theory**

Economists have strictly criticized to profit maximization theory through following points –

1. **Profits Uncertain:** It is thought that in profit maximization, firms are totally certain, but profit is not same anymore, because it is obtained by income and future cost, so it makes impossible to maximize the profit in such a type of uncertainty.
2. **No Relevance to Internal Organization:** Firm is not directly interconnected with internal organization. For example, some management destroy so much money that if the destroyed money is saved so wealth of firm and profit can be maximized. The management is responsible for growing total property and sells. Apart from this, the management tries to make lower cost and grow the efficiency through a program. The management work is real fact rather than more capital of stockbroker.
3. **No Perfect Knowledge:** The theory of profit maximization is based upon full knowledge of cost and arrival of own firm as well as another firms. But the fact is, firms do not have full knowledge in which they work. Actually, they have knowledge about their product and cost, but they cannot be sure for the demand curve of market. They always work in uncertain condition and by this way it becomes so weak profit maximization theory because it is considered that firm is sure for everything.
4. **Empirical Evidence Vague:** Empirical Evidence Vague is not clear on experiential level. Many firms don't agree regarding profit as a main aim. The work technique is so complex of latest firms, so they do not think only the profit maximization. Their main problems are controlling and administration. The administration's work of firms is not done by producer; it is done by managers and shareholders. They are more interested in their salaries and profit commission. Because high-tech firms are totally separate from power of controlling, so their mode of work is not oriented to profit maximization.
5. **Firms do not Know About MC and MR:** The fact is that the firms are not worried for calculation of maximum cost and marginal arrival in commercial field. Most of them are not familiar with these words. Many of them do not know about the demand and arrival curve. And some do not know about their basic cost structure. The experimental proof of **Hall** and **Hitch** showed that firm has no knowledge of marginal cost and marginal arrival. Although they are not greedy machine for assumption. As **C.J. Hawkins** said, "To give the logic that the purpose for all the firms is only profit maximization is not logical, and this is as similar logic than every student wants to get maximum marks in examination by hook or crook."

**Self Assessment****Multiple choice questions:**

4. In short-term and long-term, the firm does ..... his profit.  
(a) maximization      (b) minimization      (c) normalization      (d) none of the these
5. Under perfect competition, firm wants to become ..... among other products.  
(a) excellent      (b) first      (c) last      (d) none of the these
6. Most of the firms do not consider profit as .....  
(a) a main purpose      (b) main product      (c) main firm      (d) none of the these
6. **Principle of Average Cost Maximizes Profits:** **Hall** and **Hitch** concluded that firms do not apply the principle of equilibrium in MC and MR to maximize short-term profit. But their aim is to maximize the profit in long-term. They fix the price on average cost theory, not on marginal theory. According to the principle,  $\text{price} = \text{AVC} + \text{AFC} + \text{profit margin}$  (which is generally 10%). Thus, the main purpose of profit maximization is to fix the price on the basis of the principle of average cost, and then sell the production on same price.
7. **Static Theory:** New classical theory of the firm is static by nature. This does not tell about the duration of short-term or long-term. The time period of neo-classical firm is equal and independent periods. Decisions are taken freely. This is the big lack of theory of profit maximization. In reality the decisions are 'mutually dependent and time bound.' This means, a decision is affected from the

other last decisions, and it will affect the upcoming decisions of firms. This correlation is bypassed by neo-classical theory.

8. **Not Applicable to Oligopoly Firm:** Practically, in economic theory, the purpose of profit maximization is for perfect competitor or oligopoly or oligopoly competitor firm. But in oligopoly firm, it is left due to its criticism. Thus, the purposes added by the economists in this theory are mainly related to oligopoly or two-oligopoly.
9. **Varied Objectives:** The difference base of neo-classical firm and modern corporation is that the aim of profit maximization is related to producer's behaviour while the aim of modern corporation is basically related to various ambitions of shareholders and management. The shareholders do not affect in management working arena. In 1932, **Barle** and **Means** told that the purpose of management is far different from shareholders. The management has no interest in profit maximization. They operate the firm in their own favour rather than for shareholders. Shareholders cannot affect them any more due to having no knowledge of company. Most of the shareholders cannot present in annual meetings. In this way, the modern firms are motivated from those purposes which are related to internal organization.



*Did u know?* The firms make profit maximization in short-term and long-term.

## 18.2 Theory of Full-Cost or Average Cost Pricing

In 1919, **Hall** and **Hitch** from Oxford University campaigned for profit maximization. For this, they have created the base of questionnaire of 38 industrialists. In this 33 were producer, 3 were retailer, and 2 were manufacturer. **Hall** and **Hitch** obtained the information about their efforts under estimated maximum cost and income to make them similar, their demand flexibility. Information obtained from those responses, most of them did not effort to estimate the demand flexibility or maximum cost directly or certainly. They did not thought about the relevance of this in price decision process.

**Hall** and **Hitch** have concluded on the basis of their empirical study that many industrialists consider the full cost on the basis of sales value, they do not justify the similarity of marginal cost and marginal income, and they include the profit commission. This way the best price is based upon full or average cost which should be made by view of correct competition under oligopoly.

But what is full cost? Full cost is full average cost in which the average changeable cost (AVC), deposited average other cost (AFC), normal margin for deposit and profit. Thus, price (P) = AVC + AFC + profit margin (normally 10%). According to **Hall** and **Hitch**, there are some reasons to follow the theory of full cost pricing by firm: (i) silence or diplomat agreement between producers (ii) not succeed to know the priorities of customers (iii) responses of competitors due to changes in price (iv) moral trust of justification and (v) uncertainty of influences of price variations. These reasons stop the oligopoly producers to decide others price except deciding the price of full cost.

Thus, firms fix the prices on the basis of full cost principle and sell according to market demand. They saw that in spite of demand and cost changing in oligopoly, price is constant in market. They explained the stability of price by kinked demand curve. This kinked on that point where in Fig. 18.3, the fixed price OP (= OB) on full cost theory. Above from this level, the sell of firm will be reduced because competitors will not follow to raise the price. Because PD part is flexible. On the other hand, firm reduces the price from QP. Its is competitors will to reduce price. The sell rises but profit is less. Because PD<sub>1</sub> is less flexible. So in the situation of high or low price, non profitable condition is applicable to firms. So whenever there is no changes in price of factors (like raw material etc.) firm will be constant on price QP.

## Notes

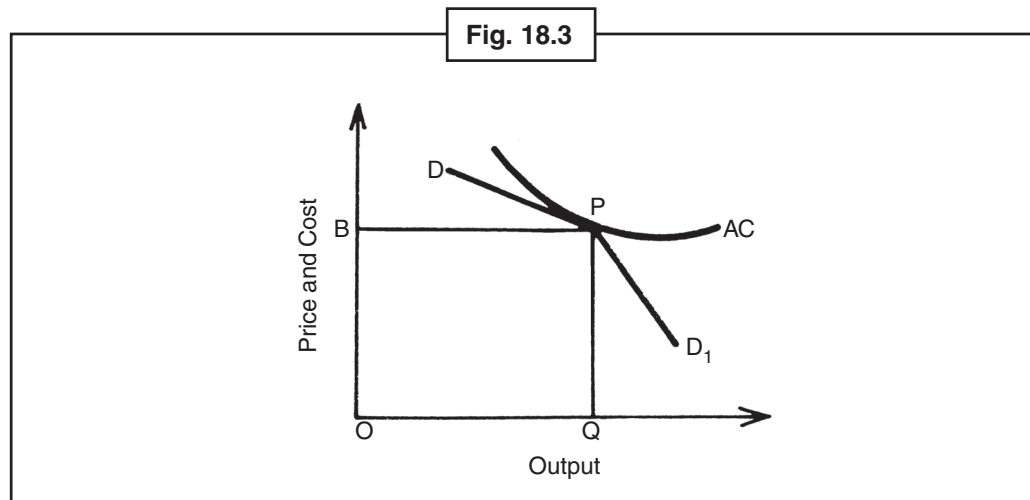

Because AC curve gets down in the is large range of production, so change in price is totally opposite from production. When the production is level down, the average cost will be more and price will be high. But **Hall** and **Hitch** do not agree on this possibility that oligopoly firm makes less production and take more prices. For this they give 3 reasons (a) oligopoly firm gives priority to price constant (b) they cannot raise the price due to kink and (c) they think, the plant will work till maximum capacity.

**Hall** and **Hitch** have analyzed two exceptions of fixed price. (1) if a demand is low and so on, price can be reduced for continuing the production level. It can be happened, as whatever said when lower part of demand curve is become flexible. When the firm is in difficult condition, price is reduced and forces for same to other firms. Any condition when the changes in technology, it influences the AC curve of firm. So, full cost value  $QP (= OB)$  is evaluated.

### Self Assessment

State whether the following statements are True/False:

7. In 1932, **Barle** and **Means** explained the purpose of management is totally separated from stockholders.
8. Modern firms are not motivated from the purpose related to internal corporation.
9. Oligopoly firm gives more priority to constant the price.
10. Kinkit demand curve makes complex to the analysis.

### Andrews Version

The description of **Hall** and **Hitch** is based on assumptions that firm has already decided the price which is to be taken in market then kinkit demand curve makes complex to the analysis. So for making the description easy about full cost prices, **Andrews's** explanation is given.

**Prof. Andrews** explained, how a firm fixes price on the bases of full cost and average cost. Firm divides the current total cost from total production to know the average real cost (AVC). On the other hand, curve is parallel to some parts of production axis, if price is shown.

Generally, a firm will state a price for a special product it will must equal to the real product making cost plus costing margin or mark up. The cost decision boundary would generally fulfill the factors of inputs and will provide the pure profit in terms of all industries.

Cost rise or cost decision boundary formula is,

Notes

$$M = \frac{P - AVC}{AVC} \text{ . So, } P = AVC (1 + M)$$

Where, M is increased value, P is price and AVC is average substitution cost.

Suppose AVC of firm is = ₹ 100 and firm M = 0.25 or 25%. Firm will decide, price P, ₹ 100 (1 + 0.25) = ₹ 125. When this price is chosen by the form whatever its production, then mark-up should be constant. But there will be still possibility of changes in mark-up (M) by the direct sources of production.

Depending on the firm capacity and available factors of production (wages and raw material), there is no possibility of change, whether the production level is anything. On that price, firm will sell the quantity demanded by customer.

But how the production level is decided? This is decided in any manner from these three – (a) percentage of production capacity or (b) in the form of last sold production in its production time period or average production which is to be sold in future. If a firm is new or starting a new product first and third point will be noted. This may be possible first will be match with third because the capacity of plant will depend upon possible sells in future.

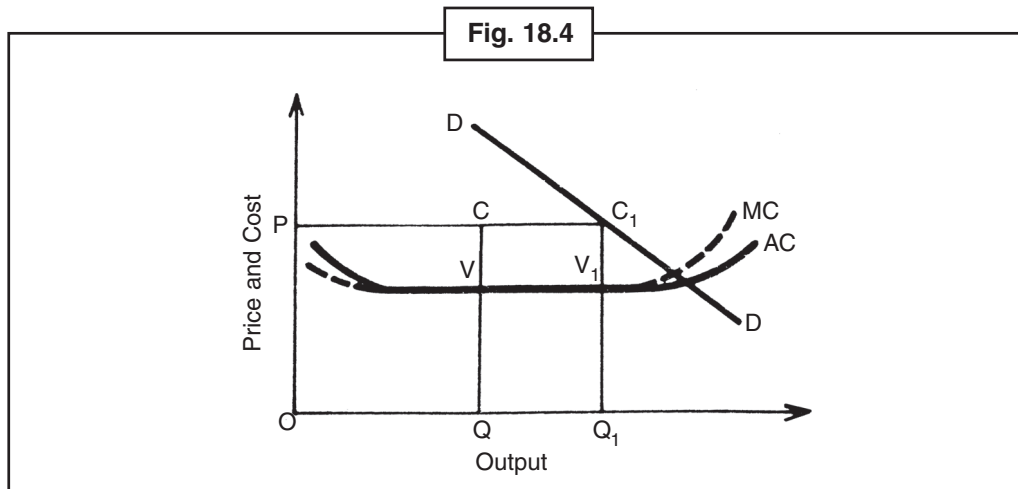

Full cost pricing of **Andrews** is shown in Fig. 18.4, where AC is parallel line in broad range of production. MC is marginal cost, suppose a firm selects a production level OQ, on this level QC is total cost. Therefore, the selling price of firm is OP = QC. Firm will take to continue this price OP but it can sell more the demand of product. As DD demand curve is shown. In this condition, it will sell the quantity of product OQ<sub>1</sub>. This price will not be changed due to demand of product.



Task Describe your views on **Andrews'** explanation.

### Its Criticisms

**Mayculp, Robinson, Kaahan** and other economist have criticized the theory of full cost pricing on the following bases –

1. **Not Free from Profit Maximization:** The critics such as **Robinson** and **Kaahan** as more described that full cost pricing theory is not free from the theory of profit maximization in which it is found through the investigation by **Hall** and **Hitch** of firm's cost pricing decision. As **Hall** and **Hitch**

**Notes**

described in individual demand curve, the price of product on kink that is profit maximization price in marginal cost in large area and this cuts marginal income curve in discontinuous way.

2. **Whose Full Cost:** The main error of this firm due to failing of describing firm, where full cost will decide the price in oligopoly market and other firms will follow this price. Thus the possibilities of leadership of price are included in which **Hall-Hitch** and **Andrews** did not think.
3. **Firms do not Follow Rigid Prices:** Theory of full cost pricing is criticized due to joint with constant price. Firms generally down their pricing in crisis and up their prices in good condition. Thus firms follow independence price theory rather than fixed price.
4. **Profit Margin Vague Concept:** Apart from this, "Good Profit Condition" or "Fixing of Cost Price" as **Andrews** states is not clear. It is clear in theory, how cost determination limit is determined and is applied by the firms. Firm can put less or high price depending upon the cost and demand of product.
5. **Weak Empirical Basis:** The implementation of full cost theory is weak for two reasons. (i) All 30 firms, who accepted the theory, only 12 from them follow strictly. But these firms were trying to add in cost varied estimated production. Some firms have taken full cost, but few of them accepted real or preplanned production. Other 18 firms usually accepted full cost but in market time, firms are got ready to put lower price, in this situation only 2 firms told that, they would grow the price in good time. In this way various firms have explained theory of full cost. (ii) **Hall** and **Hitch** told that most of the firms were not clear about flexibility and they did not try to get the demand estimation. And the firm who did this, they obtained useless information.
6. **Full Cost Principle not Obeyed Strictly:** Apart from this, in the process of pricing decision through experimental studies in England and America, information come to know that firms estimate an average type of price decision but they do not follow principle strictly. As **Bain** has written that the group of merchants do not want to say to economist about how they decided their prices, and how is relation with opposite firm. By doing this they do not want to bare losses or do not want government interference. And they could make good image.
7. **Firms Follow Marginal Principle:** Last but not the less important, there is no support for **Hall** and **Hitch's** full cost pricing principle in the **Earlay's** study of 110 companies which are operated in America in good position. **Earlay** has not seen trust in the theory of full cost. He told that, most of the firm adopted the methods of price decision, marketing and new product. He told this price determination theory of firms as "gone away frontier".

In spite of these criticisms, full cost theory was the first effort by economists for the study about commercial firm's behaviour and after this, **Simon, Williamson, Baimol, Morris, Sayart** and **March** have studied the investigation about the firm's behaviour .

### 18.3 Summary

- Profit maximization theory is based on the assumption that, the firms have all the own knowledge and cost and arrivals of other firms but the fact is that the firm has no full knowledge by this they work. Actually, they know about their production cost, but cannot be assured for demand curve of market. They always work in uncertain condition and by this way it becomes weak to the theory of profit maximization because it is considered in theory that firm is sure for everything.

### 18.4 Keywords

- **Price-Maker:** Making the Price
- **Separation:** Isolation
- **Duration:** Time Period.



## 18.5 Review Questions

Notes

1. What is the theory of profit maximization?
2. Explain the theory of full cost or average cost pricing.
3. Comment on “Andrews’ explanation”.
4. Describe the criticism of theory of full cost pricing.

## Answers: Self Assessment

- |           |           |                 |          |
|-----------|-----------|-----------------|----------|
| 1. Profit | 2. Excess | 3. Maximization | 4. (a)   |
| 5. (b)    | 6. (a)    | 7. True         | 8. False |
| 9. True   | 10. False |                 |          |

## 18.6 Further Readings



Books

1. **Microeconomics: An advanced Treaties**—*S.P.S. Chauhan, P.H.I. Learning.*
2. **Microeconomics: Behaviour, Institutions and Evolution**—*Sampool Bowels, Oxford University Press, 2004.*
3. **Microeconomics: Principles, Applications and Tools**—*Sanjay Basotiya, DND Publications, 2001.*



Notes

## Unit-19: Behavioural and Managerial Theories of the Firm

---

### CONTENTS

Objectives

Introduction

19.1 Growth Maximization Model of Marris

19.2 Baumol's Sales Maximization Model

19.3 Summary

19.4 Keywords

19.5 Review Questions

19.6 Further Readings

### Objectives

After studying this unit, students will be able to:

- Understand growth maximization theory of Marris.
- Understand the criticism of Marris model.
- Know Baumol's Sales Maximization Model.
- Know the basic of model.

### Introduction

Some important firms' behaviour related and administrative theory are discussed in this unit. Those are – The satisfaction theory of **Simon**, the behavioural theory of **Syert** and **March**, the management theory of **Williamson**, growth maximization theory of **Marris** and **Baumol's** Sales Maximization Model. These concepts are based on those assumptions which are purely different from the profit maximization of neo-classic theory. These theories represent differences between managers and owners of big firms. We will discuss the behaviour related and administrative theory of firm.

### 19.1 Growth Maximization Model of Marris

**Marris** has developed a growth maximization model of a firm in economics and mentioned in his book *The Economic Theory of Managerial Capitalism (1964)*. He proposed the theory upon that the modern big firms have run by managers and shareholders are owner who take decisions for managerial status of firms. Managers want to grow the rate of production of firm and shareholders want to grow their shares and profits. To maintain a relation between firm's growth and price of shares, **Marris** has developed a steady state model, in which manager selects a fixed growth rate on

which the assets and selling profits etc. are grown. If he selects the high growth rate then he needs to pay on advertisement and R&D for making new product and demand. So he will take more average profit percentage to himself for spreading the firm. As a result, the profit distributed to shareholders will be less and thus, the price of share will decrease. The treat to take over the firm with managers will see. Since managers are keen interested to safe their jobs as well as firm's growth, so they select a growth rate, which gives the maximum rate to shares, gives satisfied profit to shareholders, and prevents that firm to take over by another. On the other hand, owner (means shareholders) wants the stable growth of firm because by this he gets good return of the capital. So the purpose of managers and shareholders are similar and both want to get a perfect stable growth for firm.

### Self Assessment

#### Fill in the blanks:

1. Oligopoly is not ..... to others.
2. All main items like profit, selling and ..... grow in a similar rate.
3. Firms grow by .....

### Its Assumptions

**Marris** model is based on following assumptions:

1. It applies a fixed price base.
2. The production cost is given.
3. Oligopoly is not related to each other.
4. The service price has given.
5. Firms are grown by diversification.
6. All main items like profit, selling and cost grow in a similar rate.

### The Model

On the above assumptions, the purpose of firm is to maximize its growth rate (G). G itself depends upon two factors – first, the growth rate of product for firm; and second, the growth rate (GS) of capital fund. Thus,  $G = GD = GS$ .

However, the ownership is different from administration in all modern big firms, but the main purpose of managers and owners is the stable growth of firm. According to **Marris**, there are two utility functions for the owner of firm and managers. The utility function of managers includes his income, power, security of job etc. while the utility function of owner includes profit, capital, parts of market etc.

Thus, the purpose of manager of a big firm is to maximize his utility and his utility depends upon the growth rate of firm. However, the main purpose of him is to maintain the growth of firm, but he also needs to secure his job. The security of job of manager depends upon the satisfaction of shareholders, whose main purpose is to maximize the share price as well as the profits. Marris analyzes those factors by which firm try to fulfill its profit maximization growth. The firm produces new product, creates demand for new product and expands its shape. **Marris** told this **Differentiated Diversification**. To create a new product depends upon rate of diversification, advertisement expenditure, R&D expenditure etc.

Notes



Notes

The security of job of manager depends upon the satisfaction of shareholders, whose main purpose is to maximize the share price as well as the profits.

**Marris** has mentioned the relation between growth and profit by diversification of new product. The relation between growth and profit is different in various levels. In this growth-profit relation, growth is determined to profit. When the growth rate of a firm is low, the relation between them is positive. When new products are created, firm advertises and profit creates. The growth-profit relation gets negative when the growth rate rises by diversification of new products. This happens due to managerial Constraints which prevents the further growth of firm. The managerial ability is limited to face more than extra changes in firm. To promote and marketing of the new product, there is no possibility to develop a big team of administration. For the high rate of diversification, the R&D and advertisement cost is more. As a result, after a fixed growth rate, there is lower profit rate by high growth rate. It is shown in Fig. 19.1 where GD curve rises first, goes to high point M and downs further. Another factor of growth-profit is the growth rate of capital supply. The purpose of shareholders is to maximize the growth rate of capital stock. The main source for its growth is profit. So the profit determined towards supply. It collects more funds from capital market. Thus it provides funds for high growth rate. It gives negative and positive relation between profits and growth. It is shown by a straight line GS from original in Fig. 19.1.

For equilibrium of a firm, the profit growth and growth supply should be satisfied. It happens when both the curve GD and GS cut on a point where growth-profit is optimum. Suppose that in Fig. 19.1  $GS_2$  curve cuts GD curve on point M, then profit maximization happens. This point does not give optimum solution because it needs more growth which does not match with profit in long run. As long they take growth curve to point M, it shows the desire of his job security. His job security is in danger positive while shareholder feels that the price of share and profits is decreasing and another firm will take over this firm. It will affect the growth rate of capital supply (GS).

According to **Marris**, Reciation Ratio determinesd the growth rate of capital supply. If reciation ratio is low, it means all profits are distributed among shareholders. As a result, there is limited fund for firm growth available to managers and the growth rate will be very low. The growth-supply curve will like  $GS_1$  curve. The equilibrium point of firm will L, where  $GS_1$  curve cuts GD curve. This is also not the optimum equilibrium point of firm because on this point, the growth rate is low and profit is low from its maximum level.

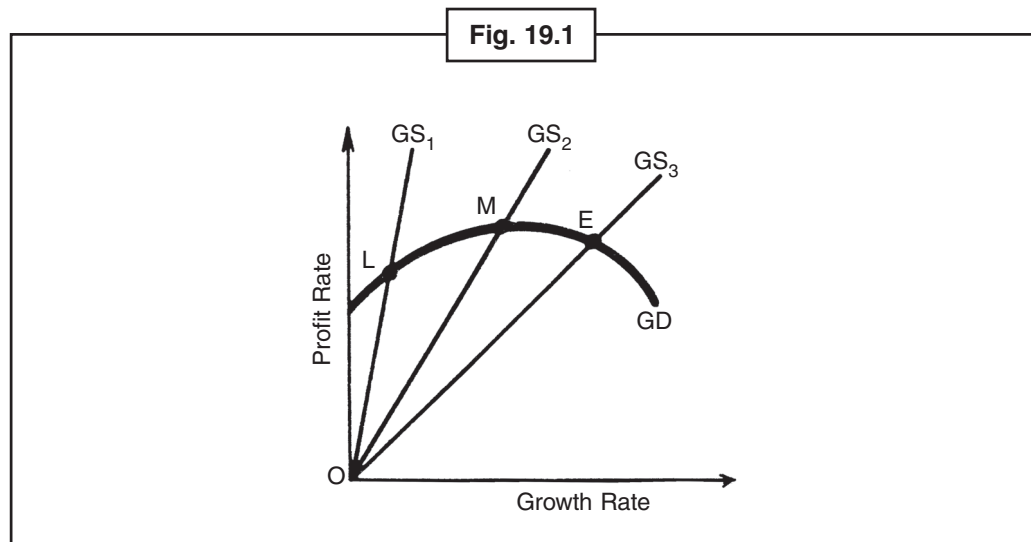

Notes

For growth of a firm, managers need to get more reciation profit for investing more funds. This rises the reciation ratio, which further gets close to high profits and high growth rates until the profit point not goes to M. This is also not a optimum equilibrium point of firm because managers feel that the combination of high profit and high growth rate is approved by shareholders and it does not affect his job. So he will want to get more reciation ratio, will invest more funds, will advertise and will grow the firm's growth rate. As a result, growth-supply curve will flat and will look like  $GS_3$  as shown in the place of  $GS_3$  curve where cuts at point E in Fig. 19.1. On this point, the distributed profit is low for shareholders. But it is in good quantity to satisfy the shareholders. There is neither fear of falling price of shares not to controlled this form by the forms. Job is secured for the managers also. Thus, point E is the optimal balance point of the form. If managers apply more reciation ratio then the distributed profit will decrease more and the shareholders will not satisfy which warned the job security to them. Current shareholders can take decision to change managers. If the distributed profit among shareholders gets low and thus, the share prices fall then that firm can take over by another.

**Marris** has defined the fear of takeover the firm by another in the form of valuation ratio, which works as a blockage in its growth rate. Valuation ratio is the ratio with its book price of the share of the firm. According to **Marris**, firm will not want to grow after a point because high point is warning for financial security and they will need minimum analysation ratio which gives the optimum factors of scale to shareholders. The valuation ratio can be affected by the rate of new shares. The relation between valuation ratio and growth rate has described in Fig. 19.2, where the valuation ratio is shown in horizontal axis while growth rate is shown in vertical axis. The share of valuation ratio is parabolic which is V. This is due to stock market behaviour and growth rate in equation of G. When growth rate is  $G_1$ , the top most point of valuation ratio is M. In this point, when growth rate increases then profit rate also increases. The growth rate of firm is expected to rise as point M of  $G_1$ . This happens because the managers will be ready to exchange the profit of high valuation ratio against the high growth rate of firm. So they will select high growth rate  $G_2$  and valuation ratio  $V_1$  accordingly. This is minimum valuation ratio which protects the firm to take over and gives high returns of scale.

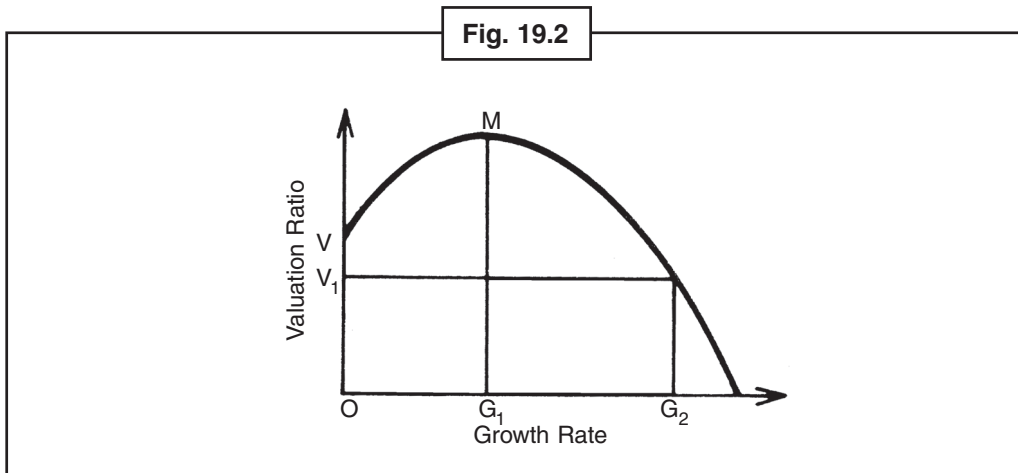

Self Assessment

Multiple choice questions:

4. According to **Marris**, the valuation ratio does ..... to the growth rate of capital supply.
 

(a) fixed	(b) low	(c) more	(d) none of these
-----------	---------	----------	-------------------
5. The valued profit is average of total profit is ..... average.
 

(a) opt	(b) rest	(c) equal	(d) none of these
---------	----------	-----------	-------------------

- Notes**
6. For growth of firm, managers need to get more reciation profit for ..... more funds.  
(a) expend                      (b) invest                      (c) exchange                      (d) none of these

### Its Criticism

The growth maximization mode of **Marris** has been criticized by **Koutsoyiannis** and **Hawkins** due to its following assumptions –

1. **Marris** proposed the price structure of firm. So he does not explain that how prices are determined in market. It is a big demerit of this model.
2. The another main demerit of this model is it does not accept the correlation between oligopoly firms in non-collusive markets.
3. This model does not explain the dependency of non-price competition.
4. Model is based on that assumption that firms can grow easily by creating new products. This is unreal because no firm can sell anything to consumer. The consumer wants a unique brand which can change with the new product.
5. According to **Koutsoyiannis**, the model of **Marris** basically applies on those firms which produce consumer goods. This model does not explain the exchange industry or business of businessmen.
6. **Marris** has collected the expenditure of advertisement and R&D in his model. It is another demrit of this model because these units are not same in a given period of time.
7. **Marris** assumes that firms have its own R&D department on which they expend more to get a new product. But in fact, most of the firms have no R&D departments. They follow the notion of other firms for product diversification and give royalty to develop models.
8. The assumption that all units like profit, selling and cost increase in a same rate is excess.
9. The assumption is that firm will grow in a fixed rate. The firms grow in a fixed rate but later slowly.
10. It is impossible to decide that point which makes the market value of share of firms as maximum and firm can overtake by another.

## 19.2 Baumol's Sales Maximization Model

**Prof. Baumol** has proposed administrative theory of firm in his book *Business Behaviour, Value and Growth* (1967) on the basis of sales maximization. He described two models of sales maximization – One static model and second dynamic. We would discuss only the static model with single product without advertisement, with advertisement and various product models.

### Its Assumptions

This model is based on following assumptions:

1. Firm has a period of time.
2. Firm wants to get more to its total selling revenue in long run which is fixed with its profit constraints.
3. The minimum profit balance of firm is fixed competitively with the price of its share in market.
4. The firm is oligopolistic which cost curve is U-shaped and the slope of demand curve is downward. The total cost curve and revenue curve are traditional.

### The Model

To check the oligopolistic firms in America, **Baumol** has found that they follow the purpose of sales maximization. According to **Baumol**, in modern firms even the management and owner are divided,

the managers want high salary and designation on the cost of sales maximization on profit cost. As a consultant of various firms, **Baumol** has seen that when he asked various managers about the last year business then they always replied, "Our sale has increased by three million dollar." Some other managers replied they, "May God increase their sales." They do not talk on their profits. So according to **Baumol**, the revenue or sales maximization and not profit maximization does match with firm's behaviour. But the purpose of management is sales maximization for short and long run. He gives many proofs to support his theory. According to him, a firm gives more important to its shape of sales and thinks more if sales get low. If the sales of firm get low then the bank, lender and capital market do not ready to give fund. Its own stockist and businessman do not take interest on it and consumer also does not want to buy their product because it is getting in lost. But if the sale of firm is high then shape of firm is also increased means it gets profit more.

**Model with Single Product**—The sales maximization means maximized total revenue as per **Baumol**. It does not mean increasing of sale of quantity product but increase in monetary sales (like Rupees, Dollar etc). The sale can go to profit maximization where marginal cost and marginal revenue are same. But if it increases from this point, then the profit remains same and monetary income increases. But the oligopolistic firms want that it monetary income should increase even its profit is minimum. The minimum profit depends by the necessity of sales maximization and to continue profit of sales. It is essential to invest monetary money in future. According to **Baumol**, "Maximum revenue will only get on the production where the elasticity of demand is equal to units means the marginal revenue is zero which is the condition for profit maximization in equal marginal revenue." It has shown in Fig. 19.3 where profit maximization firm produces OQ quantity which MC and MR curve meet on point P but sales maximization firm will produce the quantity where MR curve is zero.

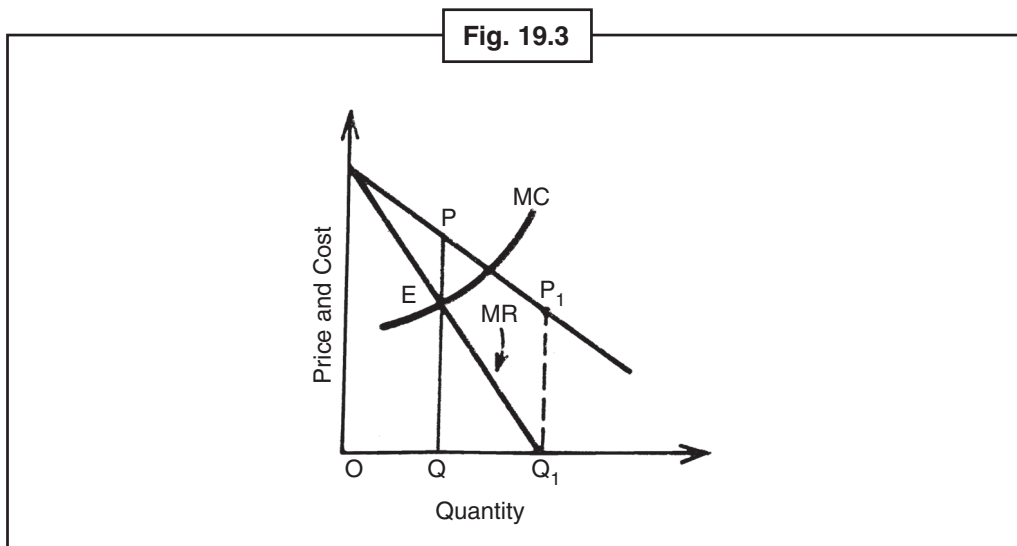

The **Baumol** model is shown in Fig. 19.4 where TC is total cost curve, TR is total revenue curve, TP is total profit curve and MP is minimum profit or profit constraint line. Firm gets its profit maximization of production on OQ level of TP curve's highest point B. The purpose of product firm is sales maximization and not profit maximization. Its sales maximum production is OK where total revenue KL is maximum on the highest point of TR curve. Sales maximization is subject to minimum profit constraints. Suppose that minimum profit level is shown by MP line. DE will not maximize the production sale because the minimum profit OM is not done by total profit KS. It is the level of OD production, where minimum profit DC (= OM) is according to the price DE/OD of total revenue DE.

Notes

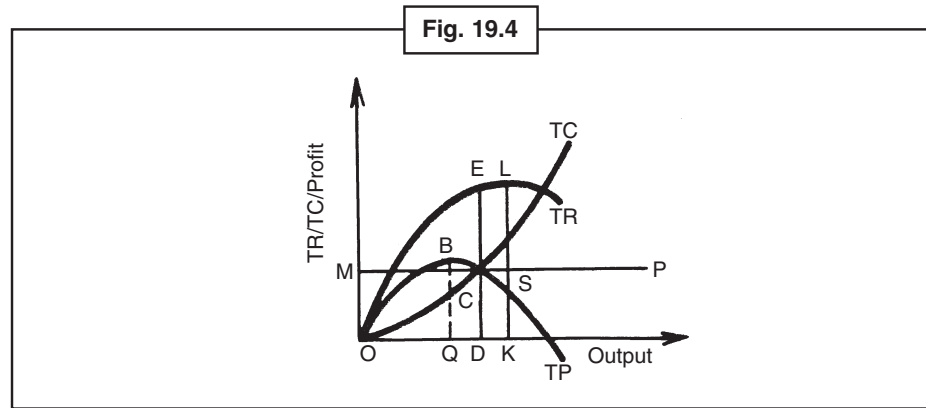

The oligopolistic **Baumol** model describes that the maximum profit production  $OQ$  will low by maximum sale production  $OD$  and price will high. The reason behind the price is low in sales maximization is that the total production and the total revenue are on high, while in profit maximization; total production is lower than total revenue. Suppose that in figure  $QB$  is jointed by a line  $TR$ . According to **Baumol**, "If on the point of minimum profit, firm gets more profit than essential minimum, then the profit maximization firm will get profit by lower their price and increase in physical production."

**Model with Advertising**—Further **Baumol** has indicated that the profit constraint is effective in sales maximization and increases the revenue of firm. The expenditure in advertisement is in vertical axis and total revenue, cost and profit are in horizontal axis in Fig. 19.5.  $TR$  is total revenue curve.  $45^\circ$  line  $ADC$  is advertisement cost curve. By collecting in  $ADC$  curve, as equal to  $OC$  a fixed amount other cost; we get the total profit curve  $TP$  which is the difference between  $TR$  and  $TC$  curve.  $MP$  is minimum profit constrain line. Profit maximization firm will expend  $OQ$  in advertisement and its total revenue will be  $OS$  ( $= QA$ ). On the other hand, on given profit constrain  $MP$ , sales maximization firm will expend  $OD$  in advertisement and the total revenue  $OT$  ( $= DE$ ) will earn. Thus, the sales maximization firm expends more in advertisement than profit maximization firm ( $OD > OQ$ ) and earn more revenue ( $DE > QA$ ) on profit constrain level  $MP$ . So the sales maximization firm will get profit by increasing the advertisement cost until the profit constrain prevents it.

*Did u know?* According to **Baumol**, sale maximization means maximization of total revenue.

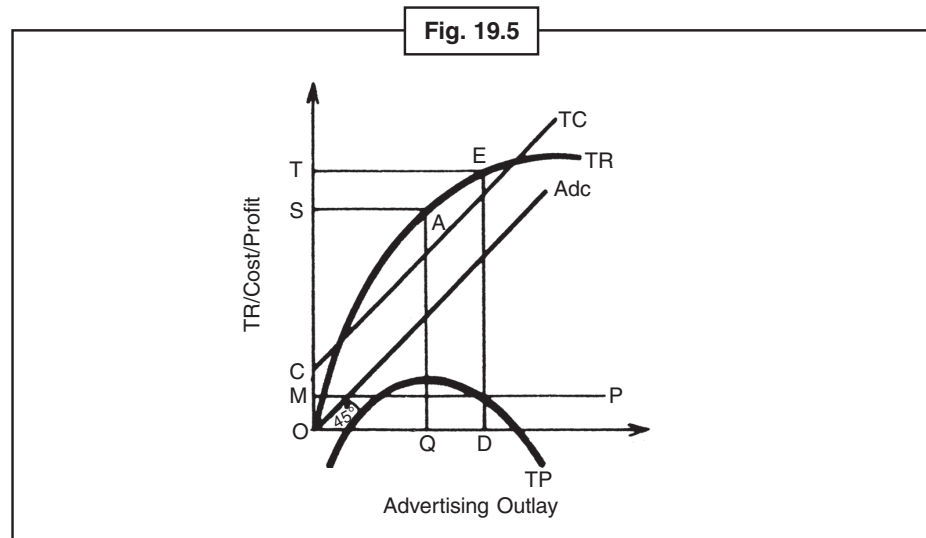

**Model with Fixed Costs** – The sales maximization firm of **Baumol** is more real than profit maximization firm because it is affected by changes in fixed costs, which is really found in industrial firms. Neo-classic profit maximization theory indicates that the production does not affect by fixed cost in short run. For example, there is no effect on production and pricing if there is a lumpsum tax in this type of firm. But **Baumol** says that if the fixed cost increases in short run due to lumpsum tax then the sales maximization firm will high their product price and low their production. It is described in Fig. 19.6 where TP is total profit curve of firm. MP is minimum profit constraint line which indicates that the firm should get OM profit by selling  $OQ_1$  production.

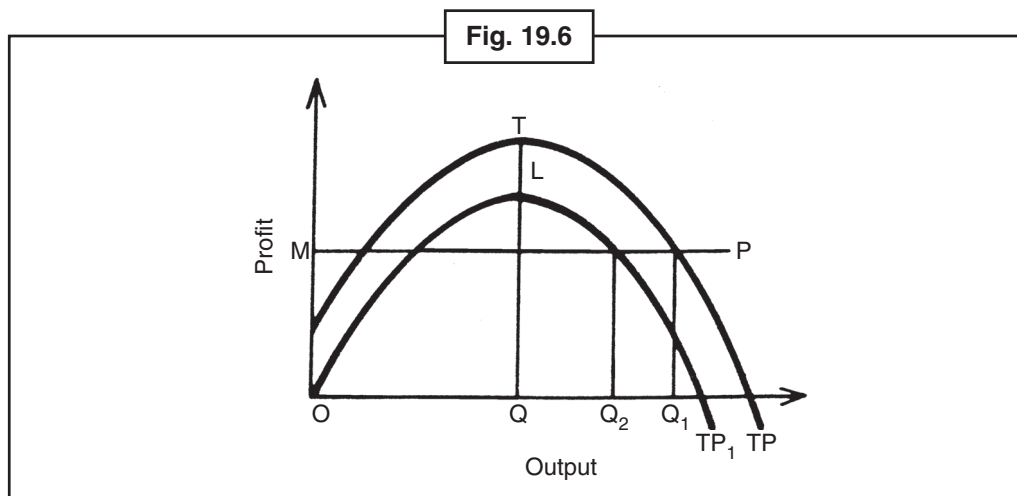

Suppose the government fix taxes are equal to  $LT$  by which its profit curve goes from  $TP$  to  $TP_1$  and firm will lower their production from  $OQ_1$  to  $OQ_2$ . Firm will increase the price of product and transfer the taxes to consumers. But due to lumpsum tax, the profit maximization production  $OQ$  does not change even the fixed cost increases.

On the other hand, after adding a specific tax like sales tax, the profit curve will slope downward left, as shown in Fig. 19.7. On the given profit constraint line  $MP$ , the sales maximization firm will slow their production from  $OQ_2$  to  $OQ_3$ . It will increase the price and transfer the taxes to consumer. The profit maximization firm will also lower their production from  $OQ$  to  $OQ_1$  and will increase the product pricing. But the production loss of sales maximization firm will high than profit maximization firm,  $Q_1Q_2 > QQ_1$ .

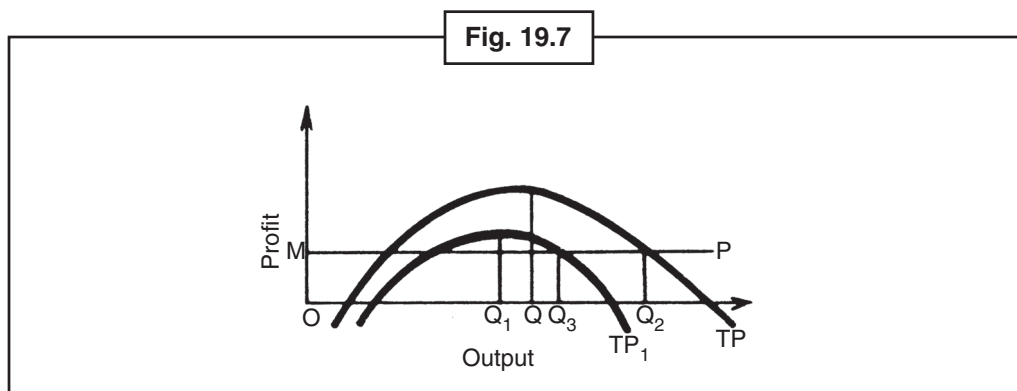



Notes

Self Assessment

State whether the following statements are True/False:

7. The sales maximization firm of **Baumol** is more real than profit maximization firm.
8. Neo-classic profit maximization theory indicates that the production does not affect by fixed cost in short run.
9. **Baumol** has described that the sales maximization firm can prevent from useful export and import by producing multiproduct.
10. According to **Baumol**, the sale maximization firm will use the difference between the highest level and the lowest level of profit for increasing its revenue.

**Model with Multiproducts – Baumol** has described that the sales maximization firm can be prevented from useful export and import by producing multiproducts. It is shown in Fig. 19.8 where product X is on horizontal axis and product Y is on vertical axis.  $PP_1$  curve indicates all combinations of X and Y which can be produced by a fixed expenditure or total cost. Curves  $R_1$ ,  $R_2$  and  $R_3$  are equal which give equal revenue by all combinations of product X and Y.  $PP_1$  and  $R_2$  curves touch point T which is profit maximization point. It is revenue maximization point which is situated in highest curve  $R_3$  which matches the expenditure given by  $PP_1$ . Thus, both firms get same result when they use similar inputs in equal quantity and fixed in similar way.

According to **Baumol**, the sales maximization firm will use the difference between the highest level and the lowest level of profit for increasing its revenue. He says this difference as 'rejected fund of profit'. "So every time the firm increases the production for increasing its total revenue, then the firm need to use the rejected fund of profit. This rejected fund of profit should distributed in various inputs, markets, inwards etc. that the monetary profit will high. This relationship indicates that sales-maximization of the firm to break even in relatively inputs and issues should avoid touching, whatever the level of total expenditure and total revenue.

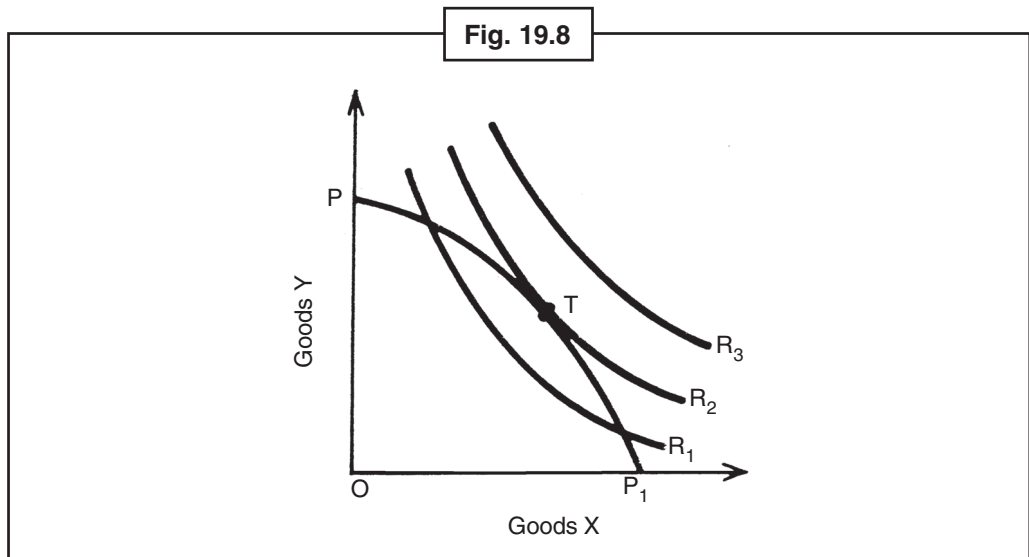

Implications or Superiority of the Model

There are some implications of **Baumol's** sales maximization model which makes greater than the profit maximization model of firm.

1. The sales maximization firm gets preference to sale rather than profit. Since it maximizes its revenue when its MR is zero, so it takes low price than profit maximization firm.

- The result shows that the sales maximization production will be higher than profit maximization production of firm.
- On the given minimum profit constraint, the sales maximization firms will expend more revenue on advertisement than profit maximization firms.
- There can be protest between the price determination in long run and short run. If the production cannot increase in short run, can be increased by increasing the price of inputs. But in long run, it is better for sales maximization firm to lower their price to get competitive for a big region of market and get more revenue.



**Task** Give your views about **Baumol's** Sales Maximization Model.

### Its Criticism

There are some criticisms in **Baumol's** Sales Maximization Model.

- Rosenberg** has criticized **Baumol** for profit constraint for sales maximum. **Rosenberg** has proved that it is not a easy task to show a firm's profit constraint. It has been shown by some figures of **Rosenberg** in Fig. 19.9. Sales revenue and profit of the firm have taken on the vertical axis and parallel axis respectively. R is profit constraint. Below this, there can be select any one combination. For example, the profit level  $P_1$  on B will give more preference than P on A. Again, in a single profit line  $P_1$ , on combination B and C, C will give more preference than B because there are more sales on C. Thus, on constraint line R, at point D and E, E will be given more preference than D which is more sales level. So, in **Baumol's** model, selecting the profit combination of profit maximization is very tough. The advertisement cost will implement till profit get constraint.

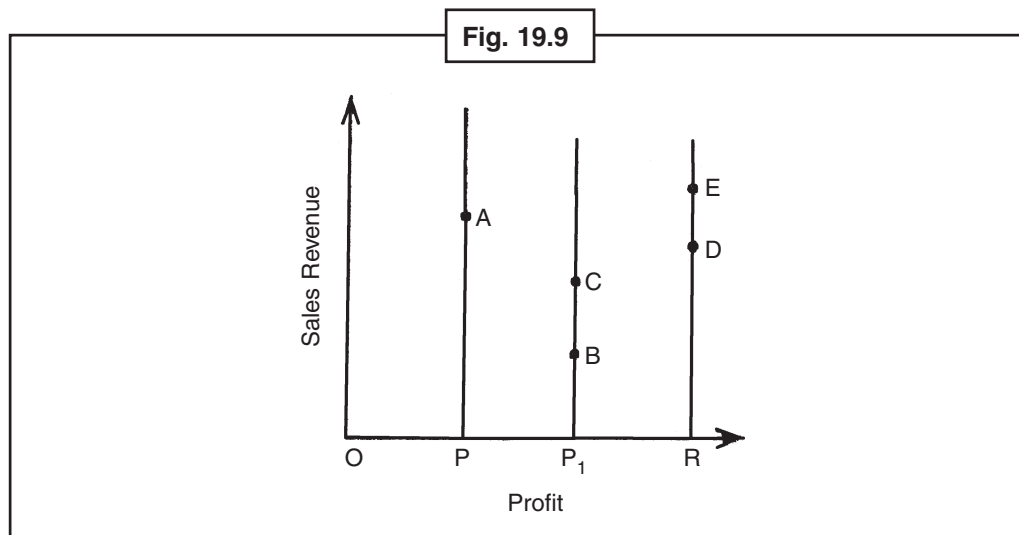

- According to **Shepherd**, an oligopoly firm needs to face kinked demand curve. If the kinked is very big then total revenue and profit will be maximum on a level only. So, the sales maximization and profit maximization firm will not produce the various level of production. But **Hawkins** has indicated that if there is any non-price competition like goods packing, free service, advertisement etc. occurs

**Notes**

then **Shepherd's** decision gets unrecognized. For example, when sales maximization expends more in advertisement, then its production profit will be more than profit maximization firm. This is so because the kinked profit of demand curve of sales maximization firm is on right side of the profit maximization firm's kink.

3. **Hawkins** has shown that generally a sales maximization firm will produce more and expend more in advertisement than a profit maximization firm, is not real. According to **Hawkins**, a sales maximization firm can select more, less or equal production and more, less and equal advertising budget. This depends upon the responsiveness of demand rather than pricing. This conclusion is for production of a product or a group of product.
4. For multiple products, **Baumol** defends that the result of revenue and profit maximization are same. But **Williamson** has shown that the result of sales maximization differs from profit maximization.
5. Another defect of **Baumol's** model is that it ignores the dependencies of pricing of oligopolistic firms.
6. According to **Koutsoyiannis**, this model of **Baumol** is not capable to rectify market conditions, where price is in non-elastic demand range for long time.
7. This model also ignores not only the real competition but also the expected competition from oligopolistic firms.
8. Again, according to **Koutsoyiannis**, model does not show that how an industry, in which all firms are sales maximized, will get equilibrium. **Baumol** has not made relation between firm and industry.

Despite these drawbacks, it can be said that sales maximization is the main purpose of modern economical firms.

### 19.3 Summary

- According to **Baumol**, the sale maximization firm will use the difference between the highest level and the lowest level of profit for increasing its revenue. He says this difference as 'rejected fund of profit'. "So every time the firm increases the production for increasing its total revenue, then the firm should need to use the rejected fund of profit. This rejected fund of profit should distribute in between various inputs, markets, inwards etc. that the monetary profit will be high. This relation indicates that in sales maximization firm, the unprofitable inward and outwards should prevent, whatever total expenditure and total revenue range is."

### 19.4 Keywords

- **Steady State:** Developed State
- **Non-Collusive:** Without Collusive
- **Profit Constraint:** Gag in Profit

### 19.5 Review Questions

1. What do you mean by Growth maximization theory of **Marris**?
2. Write comments on **Baumol's** Sales Maximization Model.
3. Explain the model with Fixed Cost.
4. Explain the implications of **Baumol's** model.

### Answers: Self Assessment

Notes

- |               |          |                    |         |
|---------------|----------|--------------------|---------|
| 1. Dependency | 2. Cost  | 3. Diversification | 4. (a)  |
| 5. (a)        | 6. (b)   | 7. True            | 8. True |
| 9. False      | 10. True |                    |         |

### 19.6 Further Readings



Books

1. **Microeconomics**—Robert S. Predik, Daniel L. Robinfield and Prem L. Mehta, Pearson Education, 2009, PBK, 7th Edition.
2. **Microeconomics – Behaviour, Institutions and Evolutions:** Sampool Bowels, Oxford University Press, 2004.
3. **Microeconomics**—Shipra Mukhopadhyay, Annie Books, 2011.

## Unit-20: Macroeconomic Theories of Distribution

### CONTENTS

Objectives

Introduction

20.1 Ricardo's Revenue Distribution Theory

20.2 Marxist Theory of Revenue Distribution

20.3 Summary

20.4 Keywords

20.5 Review Questions

20.6 Further Readings

### Objectives

After studying this unit, students will be able to:

- Know **Ricardo's** Revenue Distribution Theory.
- Know **Marxist** Theory of Revenue Distribution.

### Introduction

Total part of different sources of production of total national production of a country is calculated by Macroeconomic Theories of Distribution. In other words, under Macroeconomic Theories of Distribution groups of sources of production of total part have been calculated. Following are the Macroeconomic Theories of Distribution.

### 20.1 Ricardo's Revenue Distribution Theory

Revenue distribution theory established by **Ricardo** is an important macro theory. In this theory, whole economic system has been distributed in a group of agriculture and industry and income received through it is divided into a group revenue, wages and profit.



Notes Revenue distribution theory established by **Ricardo** is an important macro theory.

## Assumptions of Theory

Notes

- (i) Whole land is used for production of cereal and working powers engage in agriculture fixes the distribution in industry.
- (ii) The rule of decrease of production on land is regulated.
- (iii) Supply on land is unchangeable
- (iv) Labour and capital can be reduced or increased.
- (v) Demand of cereals is totally inelastic so rise in price or distribution supply does not affect demand.
- (vi) Wages are given to labours according to their standard of living.
- (vii) There is nothing progress in technical knowledge and art of agriculture.
- (viii) Rate of wages is constant and already fixed.
- (ix) Demand of labour depends on quantity of capital deposit.
- (x) There is totally competition in market.
- (xi) Both demand of labour and distribution are free from production limit means maximum production limit does not affect demand supply.

## Self Assessment

### Fill in the blanks:

1. The rule of ..... is applied on production on land.
2. There is totally ..... in market.
3. Fulfill on land is .....

## Analysis of Theory

**Ricardo's** Revenue Distribution theory is based mainly on two theories which are extra marginal and surplus theory. The marginal theory is used for determination of taxes in national productivity and the excess theory is used to distribution of wages, profit etc. from rest of the production.

The factors of production can be determined if the cereals grow is fixed. The unit of labour is the difference between the average taxes of labour and marginal production it means total taxes are the differences of average production of labour and marginal production  $\times$  the quantity of labour and capital investment on land. Profit is nothing but marginal production of labour and rate of wages. The wages of labour is determined by labour capital  $\times$  number of labour. Thus the first owner of this production of cereals is landlord and later comes labour and others.

By given figure, we can clarify taxes, cost profit or portion of national production.

In this figure on x-axis labour work and land and on y-axis agriculture production are shown. AP and MP are respectively average labour and productivity curve. Suppose that OM labour is used in agriculture then maximum production of labour is MP and average production MD is the difference in maximum and average production in labour to PD and total

$$\text{Production} = \text{OMDC}$$

$$\text{Its tax} = \text{CD} + \text{PB} = \text{CDPB}$$

$$\text{Wages} = \text{OM} + \text{KW} = \text{OWKM}$$

$$\text{Profit} = \text{BP} + \text{KW} = \text{BPKW}$$

Notes

Fig. 20.1

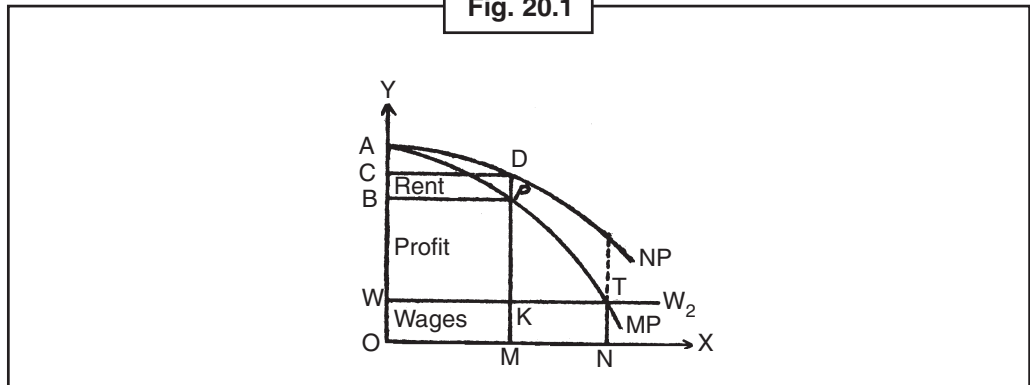

Self Assessment

Multiple choice questions:

4. For the determination of tax part in national production ..... is used.
  - (a) maximum theory
  - (b) investment curve
  - (c) distribution theory
  - (d) none of these
5. **Ricardo's** Revenue Distribution theory is mainly based on additional land and .....
  - (a) special theory
  - (b) half theory
  - (c) theory
  - (d) none of these
6. .... Found in market.
  - (a) Perfect Competition
  - (b) Competition
  - (c) Utility
  - (d) None of these

**Ricardo** in his theory found that profit is special income that means profit is that which remains after paid tax, labour cost and interest in total production.

According to **Ricardo**

$$\begin{aligned}
 \text{Rate of Profit (Y)} &= \frac{\text{Profit}}{\text{Labour Cost}} \\
 &= \left( \frac{MP - MK}{MR} \right) \times 100 \\
 &= \left( \frac{PM}{MK} - \frac{MK}{MK} \right) \times 100 \\
 &= \left( \frac{MP}{MK} - 1 \right) \times 100
 \end{aligned}$$

Self Assessment

State whether the following statements are True/False:

7. **Ricardo** in his theory found that profit is special income.
8. Demand of labour and supply both are not free from marginal production.
9. The marginal production of labour does not have any influence in demand and supply.
10. **Marx** was rigid socialist in his time.

Since MK, which is rate of labour cost of life, is unchangeable, so as cereal the rate of profit is changed with the marginal production. According to **Ricardo**, taxes increase with the progress of society and profit decreases, but the rate of real labour cost should be unchangeable. This is clarified by below diagram—

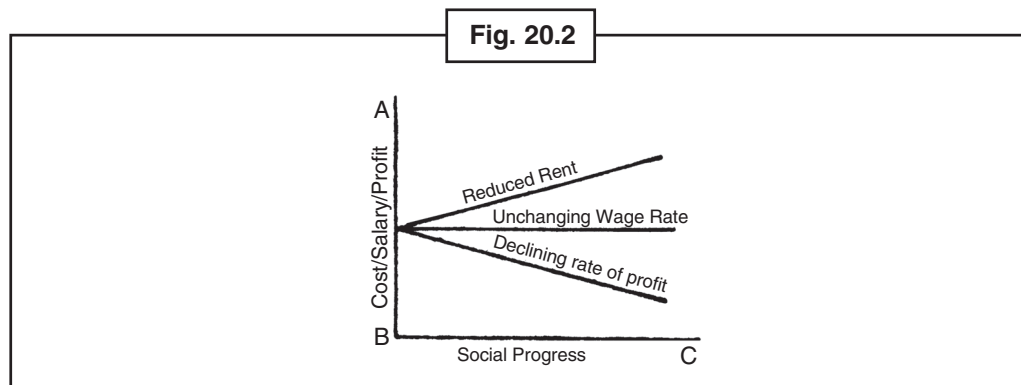

Profit is essential for capital deposit. If profit is not sufficient in quantity; it affects adversely and stops the development of economy. When the rate of profit becomes zero then the capital deposit would stop and economical situation will go to that level which **Ricardo** described as the long run stable period. The main properties of this period are – (i) rate of progress will be zero, (ii) profit will not happen or it is zero, (iii) taxes would be more and rate would be high (iv) The cost of labour would be stable in the level of life standard.



*Did u know?* **Ricardo's** theory is based on the population theory of **Malthus** and productivity loss theory.

### Criticism of Ricardo's Theory

- (i) **Unnecessary Importance to Revenue:** **Ricardo** has given more importance to taxes rather than wages, interest, profit etc. But it is necessary because every factor gets credit as per their part of services.
- (ii) **Capital and Labour is not Constant Multiplication:** **Ricardo** has accepted capital and labour as constant multiplication while this is free factor, not constant.
- (iii) **Other possible uses of land:** It is not correct that land can be used only for production of cereal but it can also be used for building construction, establishment of industry.
- (iv) **To add Interest in Profit is Incorrect:** In this theory, interest is also added in profit which is not correct.
- (v) **Based on False Assumption:** Theory of **Ricardo** is based on the utilization of theory of population and theory of production loss, but the reality is both the theories are unreal.



*Task* Express views on **Ricardo's** theory.



## 20.2 Marxist Theory of Revenue Distribution

**Marx** was a rigid socialist in his time. The theory of distribution of income established by him is based on theory of price-wages. **Marx** voted that the price of every product is based on quantity of labour. One important characteristics of labour is that it produces more than of minimum standard and he has given wages equal to minimum standard of life and difference between these two has been kept in the form of profit by landlord.

The total cost of production has following factors –

- (i) Constant Capital – Raw material and means of production.
- (ii) Changeable Stock of Capital – Wages.
- (iii) High Price – Maximum earning by labour.

Thus,

Total price of production = constant capital + changeable capital + Surplus

According to **Marx**, in capitalist economic system the exploitation of labour can be increased as following –

- (i) By increasing working hour of labour.
- (ii) By maximum use of labour.
- (iii) By technically development.

In a capitalist economic system, the parts of profit in national income have increased as technology updates and the parts of wages decrease.

### **Criticism**

- (i) **Maxist** theory of revenue distribution is unsatisfactory and incomplete.
- (ii) This theory is based on unreal assumptions.
- (iii) In this theory, variable capital has given more value.
- (iv) By law of internal structural, it cannot defect the law of rate of decreasing profit.

## 20.3 Summary

- Revenue distribution theory established by **Ricardo** is an important macro theory. In this theory, whole economic system has been distributed in a group of agriculture and industry and income received through is divided into a group revenue, wages and profit.

## 20.4 Keywords

- **Marxist:** Follower of **Marx**.
- **Revenue:** Tax.

## 20.5 Review Questions

1. What is **Ricardo's** revenue distribution theory? Clarify it?
2. Define **Marxist** theory of revenue distribution.

### Answers: Self Assessment

### Notes

- |            |                |                 |          |
|------------|----------------|-----------------|----------|
| 1. Decline | 2. Competition | 3. Unchangeable | 4. (a)   |
| 5. (b)     | 6. (a)         | 7. True         | 8. False |
| 9. True    | 10. True       |                 |          |

### 20.6 Further Readings



#### Books

1. **Microeconomics**—*Frank Cowbell, Oxford University Press, 2007.*
2. **Microeconomics**—*Robert S. Predik, Daniel L. Robinfield and Prem L. Mehta, Pearson Education, 2009, PBK, 7th edition.*
3. **Microeconomics**—*David Besenco and Ronald Brutigame, Wiley India, 2011, PBK, 4th Edition.*

## Unit-21: Macro Theories of Ricardo, Marx and Kailki

### CONTENTS

Objectives

Introduction

- 21.1 Kolder's Total Revenue Distribution Theory
- 21.2 Revenue Distribution's New Prominent Theory
- 21.3 Kailki's Distribution Theory
- 21.4 Vintrob's Theory
- 21.5 Summary
- 21.6 Keywords
- 21.7 Review Questions
- 21.8 Further Readings

### Objectives

After studying this unit, the students will be able to:

- Understand **Kolder's** total Revenue distribution theory.
- Discuss Revenue Distribution's New Prominent Theory.
- Explain **Kailki's** distribution theory.
- Know **Vintrob's** theory.

### Introduction

Many economists have given their own in relation to distribution of revenue after **Ricardo**. These economists established marginal production as the base of distribution. New prominent economists have not established a prompt theory for collective distribution.

### 21.1 Kolder's Total Revenue Distribution Theory

**Prof. Kolder** established himself a theory of total distribution of income in which he used Kensian apparatus so he called it as "Kensian Theory." According to him, the total income is earned by both - labour and owner. The returns of first group is called 'wages' and second group is called 'profit.' In wages, salary and bonus are counted and in profit, interest and revenue are counted.

**Recognition of Theory**

Notes

- (i) Perfect employment condition is available in economic system.
- (ii) In total income, total wages and total profit are mixed.
- (iii) The marginal consumption nature or saving nature is constant for labour group and owner group.
- (iv) The nature of saving is less found in labour class rather than owner group.
- (v) Additions of saving of labour and saving of owner are called Total Savings.



*Notes* The returns of first group is called 'wages' and second group is called 'profit.' In wages, salary and bonus are counted and in profit, interest and revenue are counted.

**Algebraic Explanation of Theory**

Suppose that total national income is A, total wages income is B and total profit income is indicated as C, then we can say,

$$A = B + C \quad \dots(i)$$

That means, national income is called the addition of total wages and total profit. The conception of Perfect Employment is that investment which is always equal to savings. In algebra –

$$I = S \quad \dots(ii)$$

Total savings of society will be the total addition of total wages and total profit. If savings from income of wages SB and savings SC are done due to profit income then

$$S = SB + SC \quad \dots(iii)$$

SB is used for average mentality to savings of wages and SC is the savings of getting profit earlier established in investment.

$$SB = SB \times B$$

$$SC = SC \times C$$

From equation (ii) and (iii), we get the following –

$$I = SC \times C + SB \times B$$

From (i) we have

$$B = A - C$$

Therefore

$$I = SC \times C + SB (A - C)$$

$$I = SC \times C + SB \times A - SB \times C$$

$$I = (SC - SB) C + SB \times A$$

Dividing both sides by A

$$\frac{I}{A} = (SC - SB) \frac{C}{A} + SB$$

**Notes**

Now, if we divide both sides by (SC - SB) then the equation is

$$\frac{1}{A} \cdot \frac{1}{SC - SB} = \frac{C}{A} + \frac{SB}{SC - SB}$$

Since, C is the symbol of profit and A is the symbol of national income. So, we can say that

$$\frac{C}{A} = \frac{1}{SC - SB} \times \frac{1}{A} - \frac{SB}{SC - SB}$$

Since the price of SC is fixed in the equation, so the ratio of national income (C/A) depends upon the profit of rational income 1/A. So as the rate of investment increases, the profit portion in national income would increase and the wages would be low.

**Self Assessment**

**Fill in the blanks:**

1. In economic system, perfect employment condition is .....
2. In total income, total wages and total ..... are mixed.
3. The addition of savings of wages and profit is called .....

**That condition in which conclusion is not get true:**

- (i) Real wages should be the rate of a fixed life standard wages.
- (ii) There should be a settlement between incomplete competition and traders.
- (iii) The capital product should be affected by the rate of profit.
- (iv) Total profit does not below minimum rate.

**Criticism of Theory**

- (i) **Kolder's** total revenue distribution theory is based on unreal assumption.
- (ii) It is wrong to fix the perfect employment and level of production.
- (iii) Appropriation is not free from average savings and the nature of savings.



*Did u know?* The total profit of society will be the addition of wages and profits.

**21.2 Revenue Distribution's New Prominent Theory**

After **Ricardo**, many economists have explained distribution of income. These economists have accepted marginal production as the mail base of distribution. New prominent economists do not establish any solid theory of distribution. Every prominent thought is established only by production equation of **Cobb** and **Douglass**. From the production equation of **Cobb** and **Douglass**, it is clear that how the portion of labour is unstable since 100 years.

**J. E. Meed** of Cambridge University has accepted the following assumptions by re-establishing this theory:

- (i) The rule of constant result is followed in production.
- (ii) Free and limited economical system.
- (iii) The result of every factor is equal to its marginal production.

- (iv) The factors of production have perfect employment status.
- (v) Technical knowledge rises by the time and it increases the marginal production.

Notes

### Self Assessment

#### Multiple choice questions:

4. After **Ricardo**, relation of distribution of the income discussed by .....
- (a) many economists      (b) socialists      (c) astronomers      (d) none of these
5. New prominent economists do not ..... in relation to collective distribution.
- (a) establish      (b) praise      (c) improvement      (d) none of these
6. By the production result of **Cobb** and **Douglass** establishes total new prominent –
- (a) men      (b) thinking      (c) theories      (d) none of these

### Explanation of Theory

According to **Prof. Meed**, there are three factors of production – (i) capital, (ii) Labour and (iii) Land. Corresponding portion of the means of production, nature and rate of technical development and establishment elasticity means of production depend on these two things.

### Criticisms

- (i) Theory of **Prof. Meed** depends upon unreal assumptions.
- (ii) Result of Factors is not given on the basis of marginal production because the demand of marginal theory is not possible.
- (iii) Meed has accepted factors as variable in his theory but to do this is not a easy task.



Task Express your views in **Kolder's** Total Revenue Distribution Theory.

## 21.3 Kailki's Distribution Theory

**Kailki's Distribution Theory** is based on monopoly power theory of Learner. Monopoly power means how it is independent for price evaluation. Total powerful monopoly can fix the price of his production. Total monopoly is just a delusion as Perfect Competition. The thought of **Prof. Kalki** is that the portion of wages in national income is fixed by monopoly power. As monopoly power increases, the profit increases and wages decreases but the price of raw material remains stable. In contrast if the price of raw material increases then the portion of wages increases.

### Self Assessment

State whether the following statements are True/False:

7. The factors of production get perfect employment.
8. The constant returns theory occurs in production.

- Notes**
9. According to Prof. Meed, there are three factors of production— (i) Capital (ii) Labour (iii) Land.
  10. Kailki's theory is based on monopoly power theory of Learner.

### 21.4 Vintrob's Theory

The thought of Vintrob is important in Macro Distribution Theory. According to Vintrob, the total supply curve indicates the relation on the basis of employment. Following are the receiving money – (i) Total Wages, (ii) Total Constant Expenditure and (iii) Residue or Profit.

### 21.5 Summary

- After Ricardo, many economists have given their thoughts on the distribution of income. These economists accepted marginal production as the main base of distribution. New prominent economists do not establish any solid theory of distribution. Every prominent thought is established only by production equation of Cobb and Douglass. By the production equation of Cobb and Douglass, it is clear that how the portion of labour has been unstable since 100 years.

### 21.6 Keywords

- **Revenue Distribution:** Distribution of Income
- **Wages:** Salary

### 21.7 Review Questions

1. What do you mean by Kolder's Total Revenue Distribution Theory?
2. Write Distribution Theory of Kailki.

### **Answers: Self Assessment**

- |              |           |                  |         |
|--------------|-----------|------------------|---------|
| 1. Contained | 2. Profit | 3. Total Savings | 4. (a)  |
| 5. (a)       | 6. (b)    | 7. True          | 8. True |
| 9. True      | 10. True  |                  |         |

### 21.8 Further Readings



Books

1. **Microeconomics** – Shipra Mukhopadhyay, Annie Books, 2011.
2. **Microeconomics: An Advanced Treatise** – S.P.S. Chauhan, PHI Learning.
3. **Microeconomics: Behaviour, Institutions and Evolutions** – Sampool Bowels, Oxford University Press, 2004.

## Unit-22: Marginal Conditions of Paretian Optimum

### CONTENTS

Objectives

Introduction

- 22.1 The Optimum Condition of Exchange
- 22.2 The Optimum Condition of Factor Substitution
- 22.3 The Condition of Optimum Degree of Specialization
- 22.4 The Condition of Optimum Factor Product Utilization
- 22.5 The Optimum Condition of Product Substitution
- 22.6 The Optimum Condition for Intensity of Factor Use
- 22.7 The Optimum Intertemporal Condition
- 22.8 Summary
- 22.9 Keywords
- 22.10 Review Questions
- 22.11 Further Readings

### Objectives

After studying this unit, the students will be able to:

- Know the optimum condition of exchange.
- Understand the condition of optimum degree of specialization.
- Explain the condition of optimum factor product utilization.
- Know the optimum intertemporal condition.

### Introduction

Most economists accede to that in the form of welfare standard and social welfare the practice of re-establishment has proved as a vain attempt. So prominent lecturers of modern welfare economic such as **Hicks**, **Learner**, **Lange** and others in the sense of **Pareto** have established some optimum conditions of welfare. According to **pareto** optimum, Social welfare is maximum on that time, When it is impossible to made better the condition of any power without bringing out from bad condition of other people. **Hicks** has fixed maximum condition to know social optimum of **Parato** which relates



**Notes**

to production of goods and services, uses and distribution. We show the maximum condition of prof. Rader with the help of figure.

**Their Assumptions** – Condition of first order depends on following assumptions –

- (i) That all people are free to choose among different models and do not depend on anything while their ordinal uses of result has given;
- (ii) That each production unit has freed to others;
- (iii) That it is given result to each production i.e technical knowledge has constant;
- (iv) That all means is used for production of each goods;
- (v) That each object is divisible;
- (vi) That all people by some quantity of each object;
- (vii) That each firm has tried to minimize their investment of production and maximize their production.
- (viii) That it is fully active the means of production of welfare optimum is being now describe.

**Self Assessment**

**Fill in the blanks:**

1. Each production unit has ..... others.
2. Each goods has .....
3. Means of production is totally .....
4. In production of each objects, all ..... has been used.

**22.1 The Optimum Condition of Exchange**

“The maximum rate of substitution or any two objects for each person should be equal. Which is he used.” It means that maximum rate of substitution (MRS) of any two consumer products must be equal the ratio of their price. MRS is slope of any point of curve which indicates one object. Suppose that quantity is X which a person to remain on that curve is necessary to substitute each unit of Y.

Figure 22.1 shows the optimum condition of exchange. Take A and B are two persons who have constant quantity of objects X and Y respectively.  $O_a$  is the main point of consumers and  $O_b$  is the main point of B. (See Fig. 22.1) Both axes of  $O_a$  and  $O_b$  indicate vertical side of object Y and horizontal side of X.  $A_1$ ,  $A_2$  and  $A_3$  indicate neutral map of A and  $B_1$ ,  $B_2$  and  $B_3$  show neutral map of B. Any point of this point shows possible distribution between both person and object. Take point E, Where  $A_1$  and  $B_1$  curve cut themselves. On this condition,  $O_a Y_a$  units of Y with A and  $O_a X_a$  units with X.  $O_b Y_b$  units of Y get B and  $O_b X_b$  units get X. On point E, the rate of substitution between both objects, is not in equal ratio with their prices because the slope of both curves is not equal. So between two people A and B, with two objects X and Y on point E is not the optimum condition of exchange. Let us try to find such a type of point, where the condition of a person is better than before while the condition of others would become worsen as before.

Suppose that A wants to take more objects of X and B wants to take more objects of Y. The condition of each would be better and condition of others would not become worsen under high neutral curve. Suppose that they come from point E to point R. On point R, A gets more X quantity after living some quantity of Y while B gets more quantities of Y after coming some quantities on X. The condition of B is not better because he lies at that neutral point but the condition of A on R is better because he arrives from  $A_1$  to  $A_3$  respectively high neutral point. But if A and B would come from E to P that the condition

of A is as before because he lies on that neutral point  $A_1$ . The condition of B becomes better because he goes from  $B_1$  to  $B_3$ . Only that time when both would come on high neutral curves, when they come from E to Q.

Notes

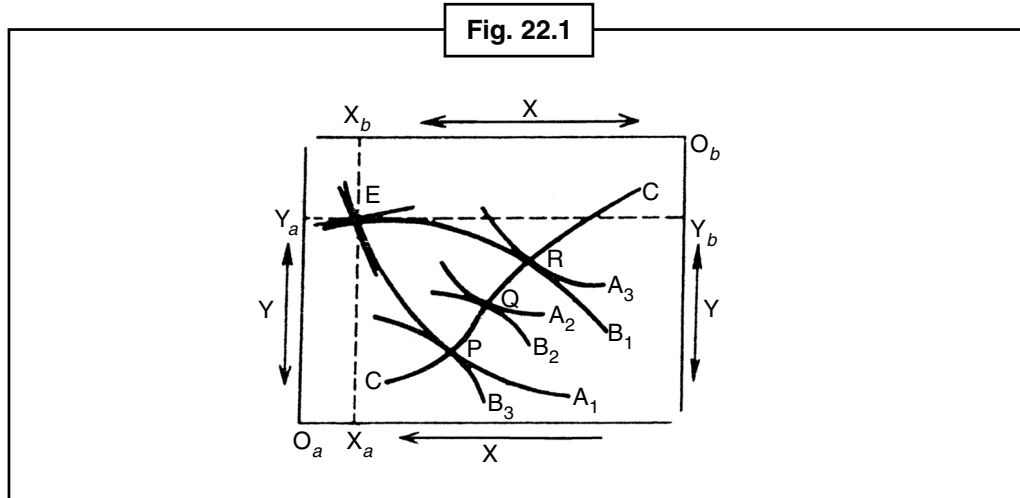

Therefore, P, Q and R are three points of exchange. Contract curve (CC) is the route of these touch-points which indicate different situations of exchange which keep equality in the rate of maximum rate of substitutions of X and Y. So on CC curve any point satisfies optimum condition of exchange. But as CC progresses in any direction, one person became better investment of others. Therefore, in the sense of Pareto, CC curve indicates optimum social welfare, but most social welfare, the real optimum points leave constant. If on the point Q of CC curve both reconsits, then this is the point of **maximum Social welfare**. But there is a fixed price. Obviously, according to **Prof. Boldring**, "In this assumption optimum point should be placed on CC curve. It is an important decision that what people want, they must get. If fixed price would accept then non-optimum point of pareto, like E, can be considered as this condition of maximum social welfare.



Notes Each person should have equal maximum rate of substitution or any two objects which he uses.

## 22.2 The Optimum Condition of Factor Substitution

The condition which relates to optimum supply demands that for any two such firms, between any two factors rate of technical substitution, should be equal by which for the production of that object these two factors are used. On the point of equal quantity of curve maximum rate of technical substitution to keep the standard production place of one other uses in the rate of substitution. This is shown in Fig. 22.1 above where we suppose X and Y are the two means and A and B are the two firms. Suppose  $A_1, A_2$  and  $A_3$  are the isopuants of firms A and  $B_1, B_2$  and  $B_3$  are the isopuants of firm B. The slope of isopuants indicates between X and Y is MRTS. Suppose that on point E, initial production is contracted. On this stage, there are  $A_1$  units of object, firm A uses  $O_a X_a$  of X and  $O_a Y_a$  of Y. Likewise for production of units of  $B_1$  of that object, firm B uses units  $O_b X_b$  and  $O_b y_b$  of X. But the maximum rate of technical substitution between both factors is not equal. By the movement of touching point between disputants the optimum condition of factor substitution is completed. CC line indicates the route of touching lines of P, Q and R. Therefore, CC curve at any point of CC curve will use the optimum of each factor'.

**Notes**

Then with CC curve, in one of the directions, production of a firm can be caused for the increment of the cost of the other firm. So, the condition indicates that any factor used for any function that will be efficient.

**Self Assessment**

**Multiple choice questions:**

5. Hicks has fixed to know the optimum of pareto ..... .
  - (a) maximum condition
  - (b) monies
  - (c) arts
  - (d) none of these
6. The factor of production is totally ..... .
  - (a) active
  - (b) motion
  - (c) efficient
  - (d) none of these
7. Each objects has .....
  - (a) divisible
  - (b) remainder
  - (c) non-divisible
  - (d) none of these
8. Each production unit with others is .....
  - (a) not free
  - (b) constant
  - (c) free
  - (d) none of these

**22.3 The Condition of Optimum Degree of Specialization**

It is necessary for the condition of optimum degree of specialisation that “For any two firms producing any two objects the maximum rate of transformation between those two objects is equal.” Maximum rate of transformation (MRT) is that rate on which the object has to leave so that on that quantity of objects maximum quantity other objects would be produced. This is measured by slope of transformation curve of any point in the figure. This condition is accepted that time, when production would be done of two objects in such a condition so that the slope of transformation is equal.

To prove this, suppose that in Figs. 22.2 (A) and (B), TA is transformation curve of firm A and PB is the transformation curve of firm B. On production possibility curve, each point of two objects, maximum possibility quantity indicates at a time. Because it is concave on main point. So, this means that for maximum production of an object maximum quantity of other objects would be left.

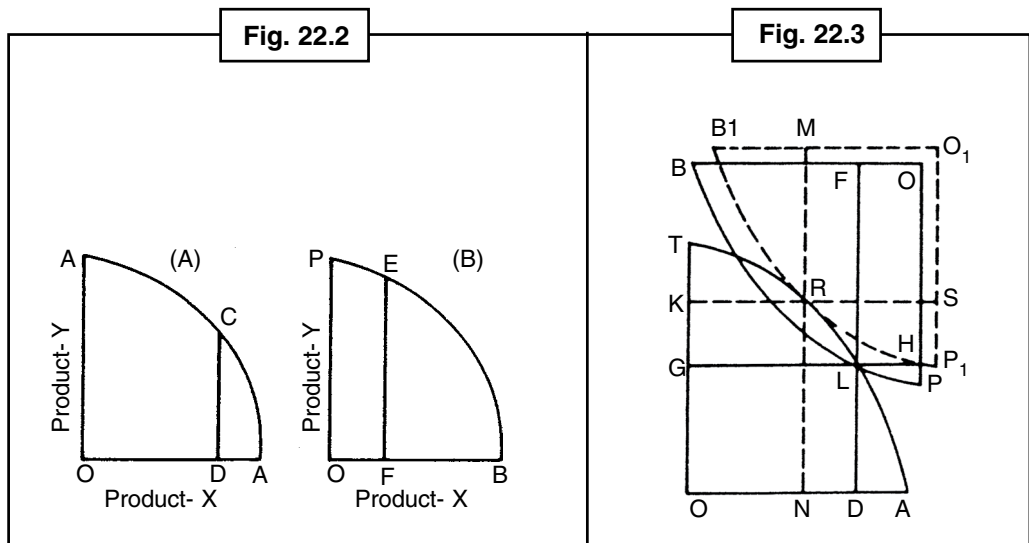

Notes

Suppose that firm A produces OD quantity of object X and DC quantity of object Y and firm B produces OF quantity of X and FE quantity of Y. Both firms produce total quantity equal to OD + OF and DC + FE of X and Y respective. Fig. 22.2 (B) keeps above 22.2 A show total quantity of X and Y in Fig. 22.3. These quantities are GH and FD respectively. Because transfer curve TA and PB cut on point L each others. So, the maximum rate of production is not equal. So, L is not the optimum point of condition because both curves are not touch point each other. But if we lift the given figure little which is shown by dash so its transferable curve  $P_1 B_1$  touches TA on  $R_1$  So the slope of both curves meet each other. This condition is accepted because maximum rate of transformation of both objects on point R is equal. This is the condition of optimum degree of specialization because total quantity produces by them is X  $KS > GH$  and  $MN > FD$  total amount of Y. It is not matter that R is the only optimum point of production for both firms. Obviously, these can be many series of this condition of optimum where both transfer curves can touch each other.

**22.4 The Condition of Optimum Factor Product Utilization**

In this condition, “between any factor and any object there should be equal transformation maximum rate which uses that factor and produces that object.’ It means that for the production of a special object, maximum rate of any factor for all firms should be equal. If maximum productivity of a factor is less to produce an object, then some units of factors transferring to more producing firm would increase total production. It has been clarified with the help of Fig. 22.4. Suppose that firm A has transferring curve if OA and Firm B has transferring curve OB which has kept opposite on the transferring curve so that axes are in parallel. Obviously, these are total producing curves and the slope has indicated the maximum rate to change of a object of factor. Product (z) produced by two firms is taken on perpendicular axis and their production is taken on horizontal axis. The point where both the transferring curve cut each other is not the point of optimum condition. To get optimum condition push curve OB upper side, so the point E touches OA curve. It is the point of optimum factor product utilization because OA and  $O_1 B_1$  slope of both transferring curves are equal and quantity of object increases from DC to KH.

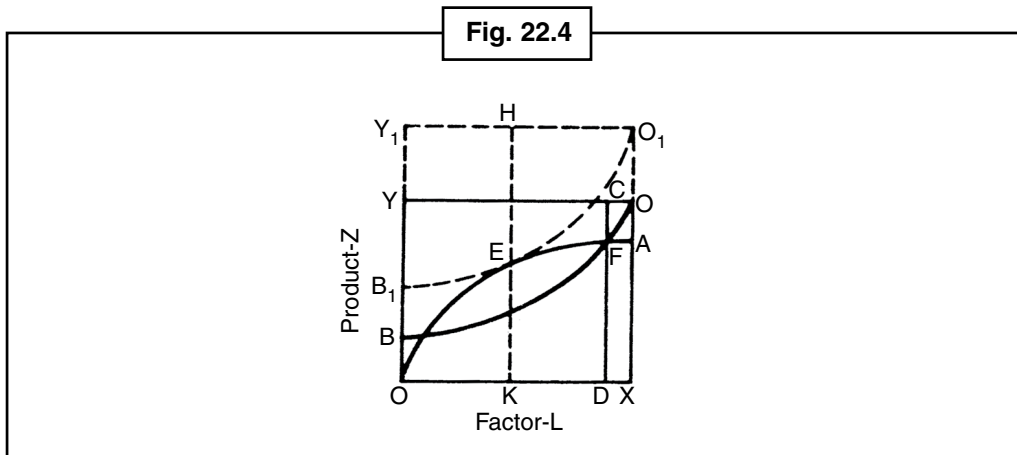

*Did u know?* For two firms producing any two objects, the maximum rate of transformation is equal.

Notes

**22.5 The Optimum Condition of Product Substitution**

It is necessary for the optimum condition of product substitute that for any person who uses any two objects (for society) transferring rate is equal to conversion transferring rate. It means that maximum rate of transferring is equal to maximum rate of any two objects. It is shown in Fig. 22.5. Suppose that curve a AB is the community transformation curve between two objects X and Y. In this figure considering  $O_1X_1$  and  $O_1Y_1$  are two axes, two objects personal consumers' neutral curves  $I_1$  and  $I_2$  are shown.

Suppose that production occurs on L where X produces ON quantity and Y produces NL quantity and consumer buys  $O_1M$  of X and ML of Y. But L is not the optimum point because the MRT is not equal to MRS on it. AB and  $I_1$  curves do not touch each other. Change from E to L and make AB and  $I_2$  curves equal. Thus point E indicates optimum condition for both producer and consumer because  $MRS = MRT$ . It means that rate on which producer is to ready to keep replacing of products X and Y equal to that rate by which X can change to Y.

According to the figure, when the consumer comes above the neutral curve  $I_2$  which at point E is the tangential to transferring curve then, from the quantity OG of X and GE of Y produced by society, consumer consumes  $O_1F$  of X and FE of Y. The last quantity OB of Y and GE of Y is remained for the cosumers of the rest of the society.

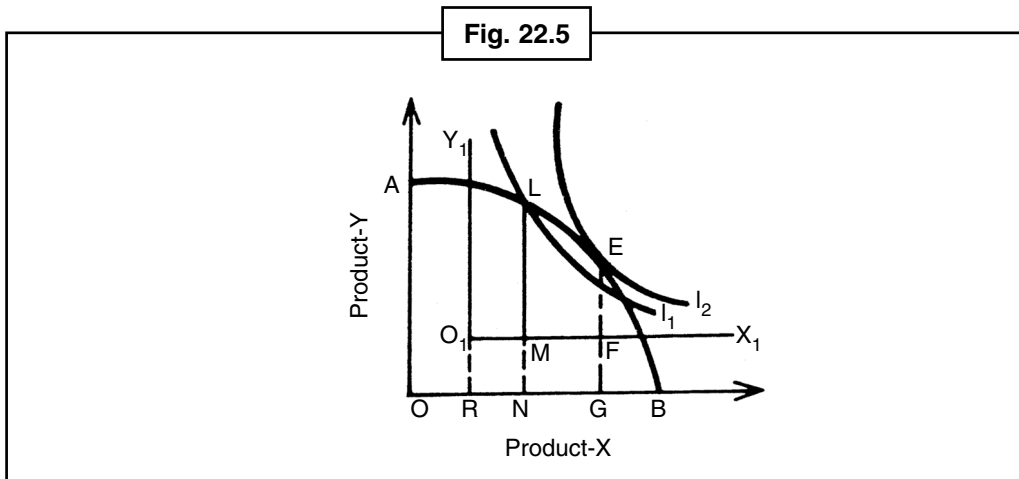

**22.6 The Optimum Condition for Intensity of Factor Use**

In the given period, the relation of a factor relates to its optimum distribution. For this, it is necessary that the transferring rate between wages of works and substitution maximum rate hour of works and maximum rate of transferring should be equal. On given period, one would feel problem to choose kindly and uses. If he uses holiday then he earns less. In reverse due to the relation between income and holiday so it has a neutral map which indicates different parts. Neutral curve indicates maximum rate of substitution between holiday and income. Likewise, factor unit object of each owner and factor unit helping in production, we consider time is a transferring curve. For this condition work and holiday the maximum of substitution, maximum rate of transformation between work and object is should be equal. If between work and holiday rate of maximum substitution work and object is greater than maximum rate 0, so time unit of factor unit transferring curves for holiday, production can be increased. Optimal condition comes on that times when the prize factor should be paid to owner factor is equal to the value of marginal productivity. It has cleared with the help of Fig. 22.6.

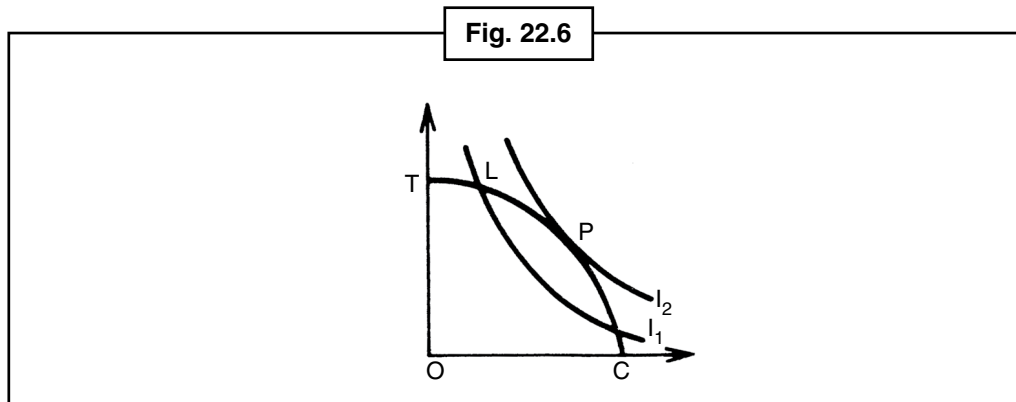

TC is transformation curve of work and production. Supposing C as a zero point of factor, factor units on parallel axis from right to left have measured horizontally. Production unit has measured vertically. So, TC curve indicates transformation between decreasing maximum rate of work and production. On the other hand, each neutral curve indicates different income with work and holiday. In this condition, income is measured on horizontal axis and holiday in hours is on vertical axis. Convexity of neutral curve indicates decreasing maximum rate of substitutions between income and holiday. This maximum condition accepts on that points where transformed curve and neutral curve both are tangent. That means their slopes are same. It is clear that L point is not point of optimum condition because on this point TC and  $I_1$  intersect each other. Maximum rate of substitution between income and holiday and maximum rate of transformation between work and production are same when a person goes above the neutral curve  $I_2$  where curve I curve TC meet each other point P. In this way this condition is satisfied at point P.

## 22.7 The Optimum Intertemporal Condition

It is important for this condition that, "The short term maximum rate of transferred between the pair of factors and object and between pair of each factor and between pair of objects, the short term maximum rate of substitutes is equal to interest on hiring without risk of securities." So, in absence of risk and uncertainty, if this condition is related to give or take loan analyzing producer. The meaning proof of this condition is that the rate of interest, on which individual product, quantity of capital is ready to take loan for taking loan producer the capital maximum productions should be equal. It can be cleared with the help of Fig. 22.6. It measures parallel axis in the form of income and vertical axis is in form of buying capability. On separate different time,  $I_1$  and  $I_2$  is neutral curve of time on different income stage with personal loan giver. It indicates decreasing maximum rate of substitution between income of present and future on neutral curve of each point. It means that on that each unit of income of a person wants high premium whose he leave for uses. TC is the time production possibility curve of personal loan. On this concave through time on each point indicates decreasing maximum rate of capital. This condition satisfies that rime when time neutral curve and time product possibility curve tangent to each other. Because both curve cuts each other on L, so this cannot be the point of optimum condition. Point P indicates optimum condition because on this point the slopes are equal on TC and  $I_2$ .



*Did u know?* Give your thought on short-term optimum condition.

**Notes** These all conditions can be collected as a whole theory as: ' the maximum rate of substitution between any two objects and factors is equal to their maximum rate of transformed and ratio of their price must be equal with each other.

### Self Assessment

**State whether the following statements are True/False:**

9. Maximum rate of transformation is that rate of which object will be quit.
10. Optimum condition comes of that time, when a factor – owner paid price is equal to maximum rate of producing of a factor.
11. Concavity income on neutral curve and decreasing indicates maximum rate of substitution of holiday.
12. Convex transformation curve and concave neutral will indicate economic minimum.

**Its Criticisms:** These marginal or first order conditions are essential for maximum welfare, but maximum welfare is not sufficient instead it can take to minimum condition in reality. Convex transformation curve and concave neutral curve will express economic minimum. So, for getting maximum welfare it is necessary to fulfill the condition of 1<sup>st</sup> type with the condition of second type. It is necessary for second type condition that all neutral curve main point should concave and all transformation curve main point should concave. But it cannot be necessary to get maximum condition. According to Prof. Bolding, "there is nothing in marginal condition which differentiates between simple mountain and Everest." So, total welfare condition of Hicks should fulfill. If we use the Bolding statement, it measure moments. It is necessary for total condition that "if welfare is to be maximum, it should impossible whose production is not done. By production of that object and whose uses are not done eluting, it should increase welfare by using that factor". Dr. Mishan is accepts these total condition as a true sufficient condition. Which if agree with maximum and second type condition then it can take to maximum of welfare. But maximum, it can be one optimum condition. Therefore in all conditions price fixation is remaining while optimum maximum condition of Pareto excludes price decision. Obviously, maximum condition is also not free from price decision. Each point on the contract curve fig. 22.1 Pareto optimal choice reflects the value judgments of them are present.

All marginal conditions satisfy in perfect competition. But in fact, these necessities are never fulfills in perfect competition because oligopoly, duopoly and monopolistic competition are found in real world. But the optimum level of Pareto can never found in monopolistic competition because the substitution rate for various consumers will never equal; the MRS will not equal to MRT for different products and factors as well as their ratio of price will never equal. To not satisfy the MRS, the main reason is the prices are always high from its marginal cost in monopoly condition,  $P > MC = MR$  by which the factors distributed faulty.

**The socialist solution:** Since under monopoly competition optimum condition of Pareto does not agree, so it enchased this statement that each Pareto optimum distribution is perfect competition and each candidate equilibrium is Pareto optimum. But Dr. Mishan clarifies that is not necessary or essential condition for obtaining optimum conditions. So the economist like Lang and Lerner have proved that under socialist for getting optimum condition, it is possible to supply prompt supply of resources. If ownership is removed in capitalizes that like capitalism, the condition of socialism can be constructed. In socialist economy planning power take the place of capitalism market and equalize the demand and supply by mixing the price of object and scripting. But distributor wishful to resources by trial and error the price of accounts can be established. Then by ratio of giving instructing to apply maximum law, optimum production and optimum factor can be receiving. When once this is obtained the efficiency of distribution then optimum condition of welfare is totally agree.

## 22.8 Summary

Notes

- Condition which relates to optimum of factory demands that for and two firms between any two factors maximum rate of technical substitution should be the same, by which for production of that object, this both type of factor is used. On any point of isopuants, the maximum rate of substitution, for production to keep the standard in place of one the rate of other factor of substitution.

## 22.9 Keywords

- **Exchange:** Change
- **Specialization:** To be special
- **True Sufficient Conditions:** Total conditions

## 22.10 Review Questions

1. What do you mean by the optimum condition of exchange?
2. What do you mean by the optimum condition of factor substitution?
3. Write a note on the optimum intertemporal condition.
4. Give four the optimum condition of produces substitute.

### Answers: Self Assessment

- |         |              |           |           |
|---------|--------------|-----------|-----------|
| 1. Free | 2. Divisible | 3. Active | 4. Fact   |
| 5. (a)  | 6. (b)       | 7. (a)    | 8. (c)    |
| 9. True | 10. True     | 11. True  | 12. False |

## 22.11 Further Readings



Books

1. **Microeconomics**—*Shipra Mukhopadhyay, Annie Books, 2011.*
2. **Microeconomics: An Advanced Treatise**—*S. P. S. Chauhan, PHI Learning.*
3. **Microeconomics: Behaviour, Institutions and Evolutions**—*Sampool Bowels, Oxford University Press, 2004.*



Notes

## Unit-23: Market Failure: Meaning and Sources

### CONTENTS

Objectives

Introduction

- 23.1 Types of Goods and Services
- 23.2 Excludable Goods and Market Failure
- 23.3 Excludable but Non-rivalrous Goods as a Source of Market Failure
- 23.4 Non-excludable Goods and Market Failure
- 23.5 Externalities and Market Failure
- 23.6 Negative Externality
- 23.7 Positive Externality
- 23.8 Externalities and the Coase Theory
- 23.9 High Transaction Costs
- 23.10 Summary
- 23.11 Keywords
- 23.12 Review Questions
- 23.13 Further Readings

### Objectives

After studying this unit, students will be able to:

- Know the Types of Goods and Services.
- Know the Externalities and Market Failure.
- Understand the Externalities and the Coase Theory.
- Explain the High Transaction Costs.

### Introduction

The market failure means the condition of market which is based upon the power of demand and supply does not capable to distribute the factors. The one of the main sources for market failure is

Monopoly Market Structure. How it happens, below are the reasons –

Notes

*In the words of J. B. Taylor, "Any situation in which the market does not lead to an efficient economic outcome and in which there is potential role of government. There are three broad sources of market failure: Public Goods, Externalities and Market Power."*

The slope of demand curve for monopoly is downward. So the average revenue is more than marginal revenue. The equilibrium condition for a firm is  $MR = MC$ . When  $AR > MR$  (and  $MR = MC$ ) then it means the price is more than marginal cost ( $AR > MC$ ). In this condition, the production is low rather than the production of perfect competition in

industry. So in the monopoly condition, however, the profit maximization is fulfilled but the satisfaction does not occur, so the market does not capable to distribute the factors.

Apart from monopoly market structure, there are some other sources of market failure. All other sources are described briefly as follows –

1. When firms work on minimum costs and exhibit the excess capacity. This type of market failure is found in monopoly. In monopolistic competition, the firm does the production on the decreasing segment of LAC, it means less of production than perfect competitive condition.
2. When property rights is not a right exclusively for an individual but an individual can use property In this condition, an individual shows his rights on a factor and it shows the maximum uses of that factor.

**Market Failure Calls Government Help**

*To get good distribution of factors, market failure seeks help from government. The government helps works on following terms –*

1. To mind on every factors of market failure correction of economical situation.
2. To help the individuals from society to accept some standard equities.
3. To affect the rate of economical development.
4. To give balance to economical situation from income and price related problems.
5. To protect and establish the property rights of individuals and couples of society.

3. When we are not able to differentiate non payers from the profit by using a product. It is generally shown in terms of roads, bridges, law systems etc. These factors are used by everyone, however, they do not pay anything for it.

4. When an economical process affects others but nobody cares about this affect. This is called Externality. It can happen either in production or consumption.

5. When imperfect information is available or information is not true or it does not spread in the market. It can be various changes or its data. Economical agents have limited information. Asymmetric information or imbalanced information is also a source of market failure.

6. When price of a product is diverged from its marginal cost by producer due to monopoly.
7. When market is not available.

**Self Assessment**

Fill in the blanks:

1. The one of the main sources for market failure is .....
2. The slope of demand curve for monopoly is .....
3. Market Failure calls .....

**23.1 Types of Goods and Services**

To get detailed information in market failure, it is necessary to get knowledge about different types of products. These types are: **Public Goods**, **Common Property Resources** and **Normal Goods**. The differences between these goods depend upon four main resources and those are –

Notes

- (i) Rivalrous or Rival Consumption
  - (ii) Non-rivalrous or Non-rival Consumption
  - (iii) Excludable
  - (iv) Non-excludable
- (i) **Rivalrous or Rival Consumption:** The consumption of a production seems competitive when the availability of this product gets low for person B if A consumes this. So both persons (A and B) cannot use that product without fulfilling the satisfaction of each other. For example, if Rahul drinks juice, Rohit cannot drink that juice; consumption by one person can exclude others from consuming a product. **So the products (like Apple, Pepsi, Cola, Machine etc.) whose availability affects by consumption of others, is called Rivalrous product.** This is also called Private product.
- (ii) **Non-rivalrous or Non-rival Consumption:** A product is non-rivalrous if a person (suppose A) consume a product but product does not get out of market. Means the similar unit is available for using more than one person.  
Park, National Security, Roads, Bridges, etc. are non rivalrous products. A park, in which everyone comes and goes and takes advantage to get relax. Thus, the persons of a nation can use the security provided by national security system.
- (iii) **Excludable:** A product is excludable when non payers cannot be differentiated from it. In other words, when the law of property rights can use as only payers can use this facility. Ramesh eats pizza but this is not available for Raju because Ramesh has ownership on this and he has only ownership to eat pizza. Thus if you have bought a car, you are the owner of car and it is your property right, so no other person can use this car without your permission. By an agreement in property right, these types of products get excluded.
- (iv) **Non-excludable:** These are the products for which no person can take rights. Roads, bridges, street lights etc., are those products which cannot be separated to use by property rights because these are the Common Property. Since the street lights are common property so it is difficult to prevent non-payers to use this.

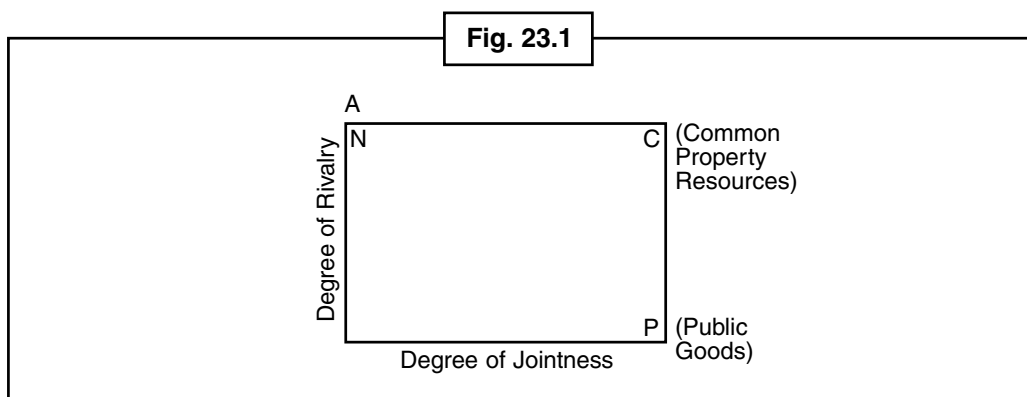

After getting knowledge about competitor, non-competitor, excludable and non-excludable products, we would learn about public goods, common property resources and common goods by the help of Fig. 23.1.

In Fig. 23.1, Degree of Jointness is mapped on horizontal axis and Degree of Rivalry is mapped on vertical axis.

**Public Goods have Characteristics of non-excludability and non-rivalry.** So we can tell that in it degree of jointness and degree of rivalry have zero quantity. In Fig. 23.1, it has shown in bottom right.

**Common Property Resources have high degree of rivalry but are also non-excludable** – This is shown by point C on the top right corner of Fig. 23.1.

**Normal Goods are Rival and also Excludable** – So it has high quantity degree of rivalry and degree of jointness is low. It has shown by point N on top left corner in Fig. 23.1.

## 23.2 Excludable Goods and Market Failure

The products produced by independent firms should generally be excluded to get profit maximization. The producer can prevent to use this product to the person who is not paying for it. If they do not do so then they will get revenue loss as well as never get profit maximization.

However, the markets can be failures even after that. Excludability is a necessary condition for market

*According to Lipsey, "Excludability is a necessary condition for goods to be produced by a firm for sale in the market."*

perfection but not a sufficient condition. Goods which are excludable may not be rivalrous. The examples are art galleries, museums, parks with boundaries etc. By using this a person cannot interrupt others. The question is that how can we

search efficient pricing system for these products? Various users will pay money as per their satisfaction level for these products.

### Self Assessment

#### Multiple choice questions:

4. The market failure is the condition which ..... the perfect economical cost.  
 (a) available            (b) agree                            (c) disagree                    (d) none of these
5. Public Goods have ..... of non-excludability and non-rivalry.  
 (a) less                    (b) emotions                    (c) characteristic            (d) none of these
6. Normal Goods are those products which do ..... to both Rival and excludable.  
 (a) available            (b) permanent                    (c) temporary                    (d) none of these
7. The producer can prevent to use this product to the person who is not ..... for that.  
 (a) work                    (b) pay                            (c) expend                    (d) none of these
8. 'Other products' are those products which fulfill the excludable characteristics but not the rival .....  
 (a) condition            (b) real                            (c) characteristic            (d) none of these

## 23.3 Excludable but Non-rivalrous Goods as a Source of Market Failure

We can say the difference between 'normal goods' and 'other goods'. **Normal Goods are Rival and also Excludable**. So these products cannot valid source for market failure. It is possible when producer fulfills the condition of differentiate means they work on that point where  $AR = MC$ .

'Other Products' are those products which fulfill the excludable conditions without any rivalry conditions. So these products are the source of market failure.



*Notes* The market failure means the condition of market which is based upon the power of demand and supply.

Notes

### 23.4 Non-excludable Goods and Market Failure

On the basis of competency, the non-excludable goods are classified into two categories:

- (i) Common Property Resources
- (ii) Public goods/products

These are some of the major market failures –

#### (i) Common Property Resources

As shown in Fig. 23.1, The Common Property Resources (CPR) has indicated on the top right side by point C where high degree of jointness and high degree of rivalry have shown. In other words, it shows rivalry and non-excludable products. So for CPR, anyone can use these products and nobody has any rights for it. To catch a fish in sea is an example of CPR. As a person catches fish is affected to another but no one can prevent or stop the other to do so, because to catch a fish in sea is nobody's exclusive right.

For example, the common land of a village has ownerships of every farmer. If a farmer grazes his sheep there, the feed for the other farmer's sheep can decrease. This is called "Tragedy of Commons" or can also be called bad episode of commons.

Thus there is unskilled use of common property. It can happen till the destruction of that property.

In CPR condition, market fails to distribute the factors in good way.

*In the words of Lipsey, "The socially optimal allocation of a common property resource occurs when the marginal cost of the last user equals the value of the marginal addition to total output."*

**Socially Optimal Exploitation of CPR** – What should the optimal exploitation of CPR? We can understand this by an example. We take example of fishing. It would be socially optimum to get a new boat for fishing if the cost to operate the boat is less than (equal to) the value of total catch by the additional boat.

Thus, in common land situation, it would be optimal if there is an increment of one sheep, if the cost of grazing (means the loss of available feed for sheep) is equal to or less than the price of milk or meat.

We have to equate marginal cost of additional user with the value of the marginal addition to total output.

**The free markets or perfectly competitive markets do not offer socially optimal solutions** – In the example of fishing, to invest in fishing industry or to put a boat in fishing depends upon that what is the cost of typical fishing boat and the cost of running new boat. In independent market, the new experimentalist of CPR increases the market until the marginal cost of last entrants is equal to average production of existing producers. Thus, the excess use of CPR shows its exploitation.

This condition is represented by Fig. 23.2.

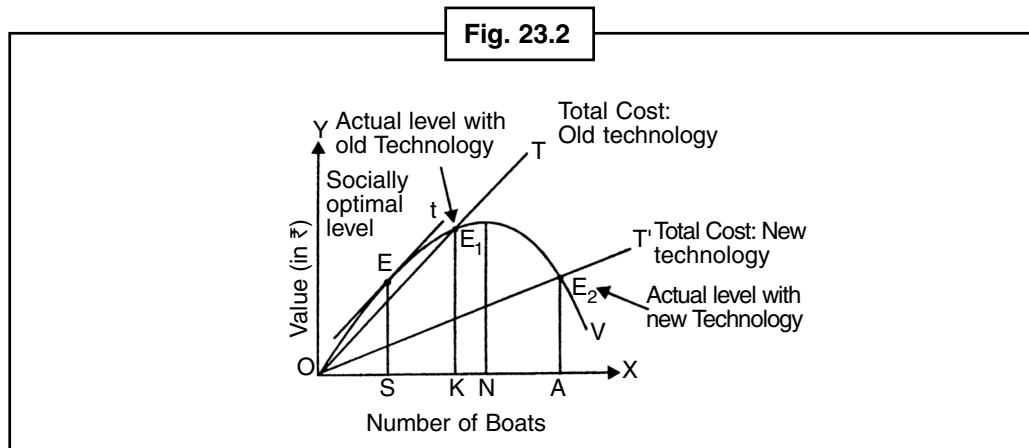

The cost of catch rises in decreased rate until ON boats not put up. After this, if extra boat is used then it shows a decreased rate. Socially, Maximum Level comes when OS boat is used.

When OS boat is used then  
T slope of curve = V slope of curve

How is it? Using old technique, the slope of curve V is equal to slope of curve V. It means that marginal profit (represented by V slope of curve as additional catch) is equal to marginal cost (represented by T slope of curve as using additional boat) means by using OS boat, Marginal Benefits = Marginal Cost.

**Note that t line is tangent to the V curve and is parallel to the T line**

In an independent market economy, the industrialist will stop at point T in fishing? The answer is NO. The reason behind this, they feel that the cost of operating an additional boat is less than expected revenue.

With old technique, fishing will continue till  $E_1$  until OK boats run and with new technique it will continue till  $E_2$  until OA boats run. Every new entrant puts his catch or average product equal to cost of operating an additional boat. But the tragedy is that he does not check his social cost in this industry. The social cost which he is missing is the loss of catch which is given to other fishermen. The reason behind this is the common property fishing is exploiting by  $E_2$  until OA boats are used till the production occurs ahead from negative marginal returns. Thus the level of production (number of boats) will high in common property factor because new entrants will not consider that loss which has given to existing fishermen.

This problem is related to all the fishery ground until the government makes a regulation in fishery.

**How can Over-exploitation of CPR be avoided?** – The CPR can be avoided or prevented by two methods.

The **first** suggestion is **Optimum Level of Use** and to restrict that level by control. It generally occurs on those conditions like hunting licenses, fishing quota etc. But there are some problems in this suggestion. However, the quantity of fishing can be restricted in sea but there is high cost include in it. If we see the international cases on quota violations then it is very high where these violations are happened after fixing the quota.

**Second** suggestion is to clarify the property rights and should make as exclusive. One CPR is rival to nature, if there is exclusive property right occurs then it means that CPR has both the characteristics of normal goods (i) Non-excludable and (ii) Rivalry. It would perfect the factors distribution in independent market situation.

But the perfection and equity has always rival. Generally in common land situation, common property rights is used to improve equity and it is definite in the cost of perfection.

The new question is that what is important–equity or perfection? The second suggestion can use after selecting from this.

**(ii) Public Goods and Market Failure**

The public goods or ‘**Collective Consumption Goods**’ is a main reason for market failure.

The public goods have characteristics of non-rivalry and non-excludability. The examples are security services, law and administration services etc. For these services, no matter who is paying for this but it is available for everyone. So these services are non-excludable. Thus the consumption of these services by one does not affect the consumption of others.

The non - rivalry virtue of public goods market can not be allocated efficiently in the plant system (in this case because the private benefits and private costs society / community get more social benefits). Therefore these objects are provided by the government and managing sources of finance.

**Notes**

When the public goods should be available and who and what should be paid? Following observations are to be noted –

(i) The public goods should be available when the addition of reservation price is equal to more than public goods. **Reserved price is the maximum price which a person is ready to pay for public goods for getting maximum or equal satisfaction.**

**Example** – The affordability of a television set in a government region of 10 families is public goods. It is non-rivalry and non-excludable. When it should be available or connected? It clarifies that the price which is ready to pay by the residents of that region is equal to or more than the total cost of television.

(ii) How much quantity should public goods be available? In normal goods situation, if a person is using goods, then others cannot use that particular goods. So in a given price, only a fixed production occurs. In other words, in the condition of general goods, horizontal summation of individual demand curve to derive aggregate demand curve and in a particular price, fixed quantity is produced. But as per the relation of public goods, some of the quantity is available for the entire person. So as the given quantity of product, its price should equal to given by every penny of a person.

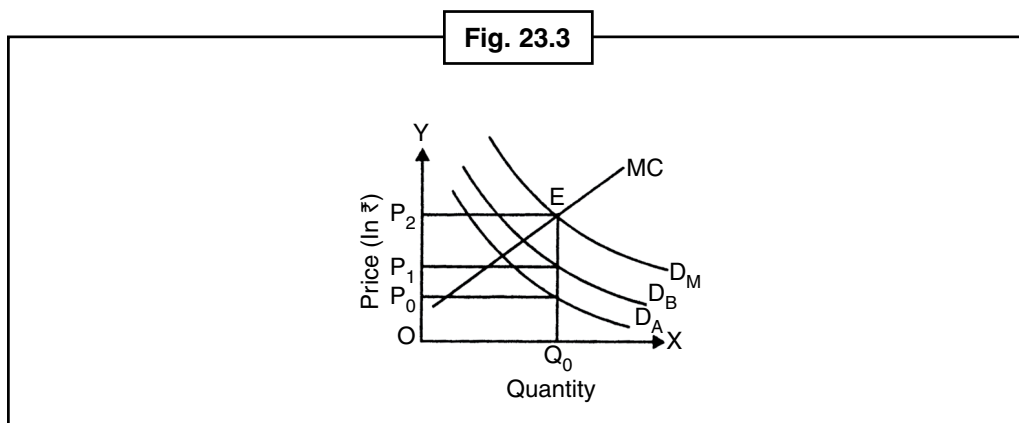

As shown in Fig. 23.3, a vertical summation for individual demand curve is extracted.

In this diagram, the demand of public goods by two persons A and B has shown as  $D_A$  and  $D_B$  curve respectively. By vertical summation, we get  $D_M$  curve which is the demand of both persons. This demand curve ( $D_M$ ) describes that how many price is ready to give for a product.

MC curve is marginal cost of public goods and it is also a supply curve.

E is an equilibrium point on which the demand is equal to supply on  $OP_2$  price. The  $OQ_0$  quantity is given for the public goods which is available for both A and B.

The cost of every unit  $OP_2$  is differentiating between both A and B. The person A pays  $OP_0$  and B pays  $OP_1$ , so  $OP_0 + OP_1 = OP_2$ .

Thus the optimum quantity is produced as  $OQ_0$  and the cost is equally distributed to its experimentalists.

But it always cannot possible that it happens by the theory of demand-supply equations. To understand this condition that the average quantity of public goods is available for all (because public goods are non-rivalry), but some experimentalists will hide the experiments of these products means they will hide of using these products.

TV in one area. In the previous example with the availability of any user other than it can use its free. in such a situation, object or substance is either not available karya TV. The cost of putting all users it has definitely not been spent for it i.e. suffered did not pay.

The government generally took the cost to get rid of free riders. The government expends the tax revenue rather than any sales revenue.

## 23.5 Externalities and Market Failure

The one of the main sources of market failure is externalities. This happens due to the lack of property rights. By 'Externality' we mean the situation when the costs or benefits related to a transaction not only affects the transactors but also other parties. This is also called **Third Party Effect**.

According to McConnel, "Externalities occurs when some of the benefits or costs associated with the production or consumption of goods 'spillover' on Third Parties i.e. or parties other than the immediate buyer or seller."

Example - If any person creates garden in outside of his home and grows various types of beautiful flowers. Now this work will not only give aroma to his neighbour but also the third person who crosses at his house. To grow the garden process is called positive externalities. Nobody will pay for it.

In contrast, if anybody fixes a generator in his house, and starts that after cutting the electricity, however that person gets light but that generator will produce noise pollution and air pollution which **negative externalities** will affect to his neighbor as well as the third party. The generator owner does not give any price for this negative externality. The negative effect bear by neighbour is called negative externality.

If this factor is not included in **decision-making**, then it creates externality and this is the reason of market failure. For example, the pollution from factories affects the health of nearby residents. But this cost cannot add in production cost. This is negative or bad externality.

To describe the externality, it is essential to differentiate the personal cost or profit and social cost or profit.

In any society, the distributions of factors are optimum when social marginal cost is equal to its social marginal benefit.

An independent market distributes factors optimally when the personal cost is equal to social cost and personal profit is equal to social profit. When social cost is more than personal cost then there will negative externality and when social profit is greater than personal profit then there is positive externality.

### The Benefits and Cost of Personal and Social

1. **Private Cost and Benefits:** In the process of production, a producer puts factors on process to get some financial award like wages, interest and taxes etc. This is private cost for a producer. **Thus the private cost is the cost which a producer bears while producing a product.** When ready product has bought and consumed by consumer and the profit gets from it is called **private profit**. This private profit and private cost has distinguished into public/social costs and public/social profits.
2. **Social Cost:** Whenever any financial process occurs, society has also bear some cost along with an individual or firm (which produces). This social cost is the social cost of financial process for society. In easy words, **the social cost is the cost which all societies bear to produce a product.** For example, the cost of vehicle runs on road is the pollution, defects of road and crowd, which is from vehicles.
3. **Social Benefits:** The social benefits are the benefits which society gets from an individual's financial process. So the society is benefited from an individual's financial work, is called Social Benefits.



Did u know? Market Failure calls the government interfere.



Notes

**23.6 Negative Externality**

When a person’s consumption or production process is affected to another person in society and he also gets negative impact and he does not get any compensation, then it is called Negative Externalities. For example, if a person established a steel factory near river and draws all pollutants in river. It clarifies that due to this process the fishes get affected. Now the question is that is this effect, the owner of steel factory would include this social cost (loss of fishing production) in his cost of steel production? Definitely not. Figure 23.4 indicates that how negative externalities become a part of market failure.

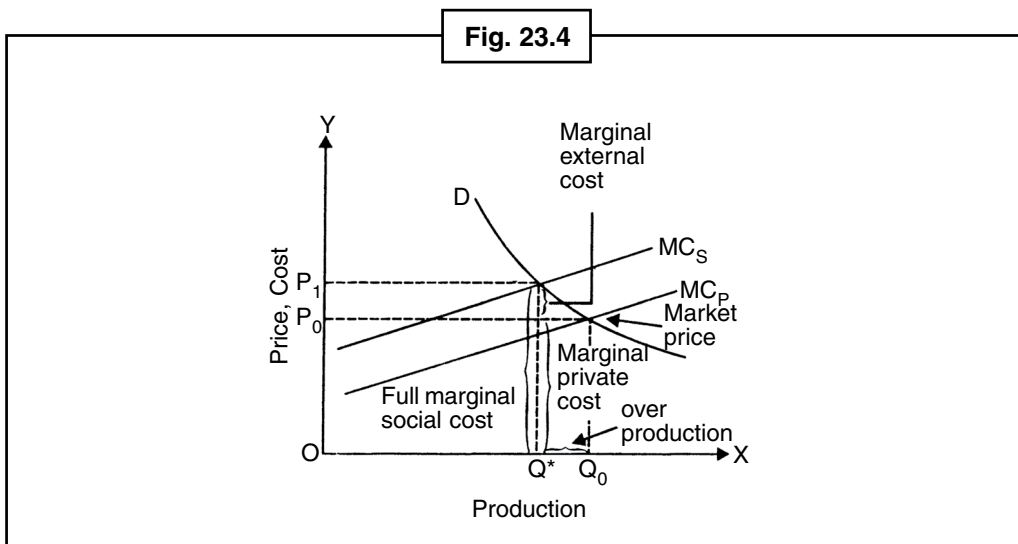

Since steel firm does not take care of its social cost, so the market price and production determination would occur by marginal cost curve and demand curve. Market equilibrium will be on  $OP_0$  price with  $OQ_0$  production. In this diagram  $MC_p$  is private marginal cost. But this does not describe the true cost because it does not include the social cost of steel manufacturer. If social cost is counted then the marginal cost curve will move to marginal external cost. The new cost curve is  $MC_s$  is which includes the external costs. The optimum production with this marginal cost curve is  $OQ^*$  units.

So the conclusion is the production will be above the optimum social level in negative externalities.

**Self Assessment**

State whether the following statements are True/False:

- 9. Independent market or perfect competitive market does not give optimum social solution.
- 10. When CPR is maximum used then nutrition is its result.
- 11. Public goods or ‘Communal consumption products’ are the main factor of market failure.
- 12. Private cost is the cost which bears by a producer to produce a product.

**23.7 Positive Externality**

When the society gets uncompensated benefit by the production produces of a producer then it is called Positive Externality. This positive externality can occur by both direct and indirect form. For example, a person has apple orchid. There is a honey farm nearby. The bees collect honey from this apple orchid, and this honey production is profitable for the farmer who is owner of honey farm. But the owner of

apple orchid does not include this profit in its marginal profit. In decision of his level of production, he only equalizes the marginal cost to his marginal benefit and does not bother about the external marginal profit of the bee farmer. Then on the basis of positive externality, which is socially expected, the minimum level of production will identify. This is represented by Fig. 23.5.

Notes

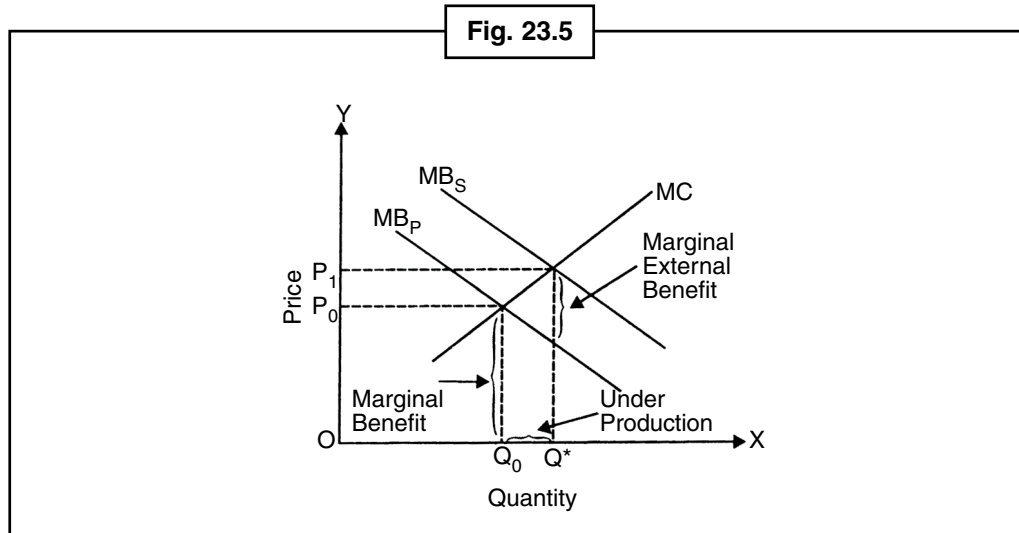

In Fig. 23.5, the productive quantity of apple displayed on axis OX, while axis OY indicates the price. The production of  $OQ_0$  units of apple occur on  $OP_0$  price, so the marginal private profit is equal to marginal cost. When outer profit is included then  $MB_P$  becomes  $MB_S$  and thus, after internalization of externality the production of apples should be increased from  $OQ_0$  to  $OQ^*$ . Thus the result is that **total output is less than the socially optimal output in case of positive externality.**



**Task** Give your opinion on Excludable Goods and Market Failure.

## 23.8 Externalities and the Coase Theory

Due to externalities, the above described problems can solve by one more method and that is the person who was responsible for this externalities should give property rights. This thinking is the base of **Coase Theory**. To develop the Coase Theory, credit goes to famous British economist **Ronal Coase** who gets the Nobel Prize of economics in 1991. According to Coase Theory, "If two factors of an externality—one who is responsible for it and the other who is affected from it can agree on an agreement that they will produce the perfect production by factors." When a product's property right is described with clarity then an agreement can sign between beneficiary and victim and then the optimum social production of that product can occur.

For example, two students A and B live in a room. A smokes, but B doesn't. Student A always smokes while reading which results bad effect on B's health. Since the air in room is collective property of both the students, so the student B cannot force student A to stop the smoking. But if the property right of air of that room can be given to one of them then, an optimum satisfaction level can be obtained from both of the students A and B. First, if property right can give to student A, then he can say to student B that to low the smoke of cigarette in air he will pay

**Notes**

suppose ₹ 1 per cigarette. Now the student B can use this money to get fresh air for himself. In contrast, if student B gets property right then he can say to student A that if he wants to smoke, he needs to pay some bucks (like ₹ 1 per cigarette). Student A can take decision of number of cigarettes and how many bucks he needs to pay to student B. Student B can take decision on money as well as the level of pollution.

### **23.9 High Transaction Costs**

Costs theory is based on the assumption that there is no agreement or transaction happens on bargain process. For example, the above cigarette smoking students, we have assumed that they can make agreement by sitting in that room. Suppose that if two agents live in two different zones then to contact each other, everyone will need to pay on telephone, fax etc. In this condition, every agent will assume his pure profit gain after transaction. He would agree for deal when he gets his profit in positive after deducting the transaction cost from his agreement. In other words, if the agreement cost is more then it may be possible then two or all parties do not ready for bargaining, no matter how well-defined the property right is.

Generally, it has been observed that in externalities, there is more bargaining costs included in profit or loss. So the private agent does not come for deal. In this situation, government includes for the perfect solution.

One more negative externality is pollution, and to prevent this, government inclusion is necessary. The three types of factor which government can use to prevent this are Direct Pollution Control, Emission Taxes and to Give Permit. Since every factor has some limitation, so it needs to use effectively in certain conditions.

### **23.10 Summary**

- Park, National Security, Roads, Bridges, etc. are non-rivalrous products. A park, in which everyone comes and goes and takes advantage to get relax. Thus, the persons of a nation can use the security provided by national security system.

### **23.11 Keywords**

- **Property Rights:** Right of Property
- **Asymmetric Information:** Disequilibrium Information
- **Rivalrous:** Opponent
- **Excludable:** Prohibition

### **23.12 Review Questions**

1. What do you mean by Excludable products and market failure?
2. Explain "Communal Property Resource".
3. What do you mean by externalities and market failure?
4. What is Negative externality? Clarify it.

### Answers: Self Assessment

Notes

- |             |           |               |          |
|-------------|-----------|---------------|----------|
| 1. Monopoly | 2. Below  | 3. Government | 4. (a)   |
| 5. (b)      | 6. (a)    | 7. (c)        | 8. (a)   |
| 9. True     | 10. False | 11. True      | 12. True |

### 23.13 Further Readings



Books

1. **Microeconomics: An Advanced Treatise**—*S.P.S Chauhan, PHI Learning.*
2. **Microeconomics: Behaviour, Institutions and Evaluation**—*Sampool Bowels Oxford University Press, 2004.*
3. **Microeconomics: Principles Application and Tools**—*Sanjay Basotiya, DND Publications, 2010.*

## Unit-24: Pigovian Welfare Economics and Externalities

### CONTENTS

Objectives

Introduction

24.1 Concept of Welfare

24.2 Pigovian Welfare Conditions

24.3 Analysis of Divergence between Private and Social Costs and Returns, or of Externalities or External Effects

24.4 Pigou's Concept of Ideal Input

24.5 Summary

24.6 Keywords

24.7 Review Questions

24.8 Further Readings

### Objectives

After studying this unit, students will be able to:

- Understand the concept of welfare.
- Know the Pigovian welfare conditions.
- Discuss the Pigou's concept of ideal output.
- Explain the external economies of production.

### Introduction

The first recognized work on the welfare economics is "*The Economics of Welfare*" by **Professor A.C. Pigou**. **Professor Pigou** is considered as the father of welfare economics because **Dr. Little** has indicated, welfare economics started with **Professor Pigou**. Prior to this, we had Joy Economics and before that Monetary economics. **Pigou's** welfare economics can be divided, for convenience, into three parts—(1) concept of welfare; (2) welfare conditions; and (3) analysis of divergence between private and social cost and returns. We will study these accordingly.

## 24.1 Concept of Welfare

According to **Pigou**, welfare exists in the mind and conscience of a person which is made out of his/her needs and utilities. Thus, the extent to which a person's needs are fulfilled is necessarily the base of his/her welfare. In a society, social welfare is considered to be the central point of the welfare of all the people. As general welfare is a detailed, critical and an unusual concept, therefore, **Pigou** has limited his study to economic welfare only. He says that economic welfare is not an indication for total welfare because several elements of total welfare such as the value of work, environment of a person, human relations, post, residence, government security, etc. do not exist today in economic welfare. Therefore, he considers economic welfare as that part of social (general) welfare which in a direct or indirect way it is addressed as the criterion of currency. Therefore, according to **Pigou** the concept of welfare is the satisfaction or use of products or services of a human being.

### Self Assessment

#### Fill in the blanks:

1. The Economics of Welfare written by **Professor** ..... is the first recognized epic on welfare economics.
2. Welfare economics was started by **Pigou**. Prior to that ..... economics existed.
3. According to **Pigou**, ..... exists in the mind and conscience of a person.

## 24.2 Pigovian Welfare Conditions

**Pigou** considers welfare and national income as, necessarily, co-ordinate. On the basis of this, he fixes two conditions to maximize the welfare.

First, the first condition specifies that when there is an increase in national income. There is an increase in welfare. If tastes and income distribution are given, the increase in national income represents the increase in welfare. According to **Pigou**, in most of the situations there will be increase in national income if there is an increase in the disutility of the work.

Second, to maximize the welfare, distribution of national income is essential. If the national income remains stable then the transfer of income from rich to poor will further the welfare. According to **Pigou**, such transfers have less impact on rich than on poor, as a result of which the economic condition of the poor improves. This welfare condition is based on **Pigou's** dual concepts "equal capacity for satisfaction" and "Diminishing marginal utility of income". **Pigou** argues that different people obtain equal satisfaction from the same real income and those who are now rich are different from those, in nature, who are now poor as the rich have more probability of consumption than poor. On implementing the rules of utility, transferring the income from rich to poor, by controlling the less immediate necessities of rich to fulfill the more immediate necessities of poor, the social welfare is increased. Thus, only economic equality can maximize welfare.

**Dual criterion** – To understand the progress in social welfare, **Pigou** adopts a dual criterion.

**First**, increase in national income or increasing some commodities without increasing some other commodities or shifting some resources for such activities, where their social relevance is maximum, is considered as a development in welfare provided there is no scarcity among the poor.

**Second**, any step in economics which increases the share of the poor without reducing the national income is considered a development in social welfare.

**Assumptions of Pigovian Conditions** – **Pigovian** conditions of welfare and dual criterion are based on following beliefs. Some of which have been already indicated.

**Notes**

1. Each person tries to fulfill his desires to maximum by spending on several objects and services.
2. There is also a belief that contentment derived from intra-personal and inter-personal form is comparable.
3. It is assumed that rule of diminishing marginal utility of income is implemented. It means when income increases, then the marginal utility of income decreases. As a result of this, with the use of extra income, a poor person gains more than a rich person loss, if we assume the income to be equal and that income is transferred from rich to poor.
4. Another belief is that "equal ability to achieve contentment" which is of the opinion that different people achieve same satisfaction with same actual income.

Only if these beliefs are given, **Pigou's** conditions of maximum social welfare can be fulfilled on the basis of dual criterion.

**Its criticisms** – Although **Pigou's** "The Economics of Welfare" is the first detailed analysis of economic welfare still its social conditions have been criticized below:

1. **The concept of Maximization is not clear:** **Pigou** emphasizes on the maximization of welfare but he does not specify the concept of maximization. His "maximization" is actually optimum. But this is a fixed point which is not correct because optimum is not fixed. It increases with increase in national income and decreases with decrease in national income.
2. **Pigou measures the welfare with the numerical cardinal process:** According to **Pigou**, welfare is measured by utility or contentment. Social welfare is considered to be combination of personal utilities of exchangeable commodities and services. Economists do not agree with this concept because utilities cannot be measured quantitatively. This is the reason the modern economists measure the utilities through the process of sequential ordinal process.
3. **National income is not the correct criterion for social welfare:** **Pigou's** "social conditions" are linked to national income. But estimating the national income is not an easy task. Then just by increasing the national income does not increase the social welfare. It is possible that due to inflation, an increase in national income may be visible and because of this the condition of the poor may worsen. Because of these reasons, modern economists measure the welfare on the basis of "election" instead of national income. For example, if any person elects A group of any commodity instead of B group then undoubtedly he gets maximum utility and contentment from A group. Thus, there is an increase in welfare.
4. **According to Prof. Robins, the belief of "Equal Ability of Man" does not make the study of Pigou's concept of welfare complete:** According to him, this belief is based on the principle of morality and not on scientific demonstration; this is not the decision of value.
5. **Pigou does not clarify the morality aspect of welfare:** The welfare economics is strongly related to ethics. But **Pigou** does not clarify it. The welfare economics is necessarily an idealist study in which valuable decisions and interpersonal comparisons are made. As **Pigou** does not relate these concepts with his "welfare" concepts, his "welfare economics" cannot be considered as actual study for welfare.

Due to these drawbacks, modern economists have formulated the thoughts of "amendment principle" and "social welfare function" which is an effort to give a new face to social economics.



*Notes* In a society, social welfare is considered as a congregation of the welfare of all people.

## Self Assessment

Notes

## Multiple choice questions:

4. When there is an increase in national income, there is an increase in ..... .  
 (a) welfare            (b) respect            (c) non-welfare            (d) none of these
5. To maximize the welfare ..... is important for national income  
 (a) time            (b) distribution            (c) respect            (d) variation
6. .... maximizes the welfare  
 (a) income            (b) expense            (c) economic equality            (d) none of these
7. To understand the development of social welfare, Pigou adopts ..... criterion.  
 (a) dual            (b) general            (c) economic            (d) social
8. Pigou necessarily considers economic welfare and national income as ..... .  
 (a) heaven            (b) unnecessary            (c) necessary            (d) none of these

### 24.3 Analysis of Divergence between Private and Social Costs and Returns, or of Externalities or External Effects

Amidst marginal personal and social expenses and benefits, deviation externalities or external effects or external economies and diseconomies are known. "External effects" are assumed when the productivity of a firm or utility of a person is dependent on such means that cannot be sold or bought; at least currently such means are not exchangeable. External effects (between person and firms) are also known as untraded interdependencies which can be mutual or uni-directional. External production leads to production and production leads to consumption. This consumption can move toward production as well. Externalities are positive and negative. Profitable externalities are known as positive externalities. Expensive externalities are known as negative externalities. In other words, if personal gains are more than social gains then these are positive externalities or external economies. Actually, externalities are incomplete market, where market does not pay for the service or disservice of any commodity. Due to these externalities, there is maldistribution of means because of which production or consumption is left short of required level. Thus, because of external effects, maximum social welfare is not possible. **Pigou** should be credited not only for analyzing the reasons for external effects but also for providing solutions to remove the deviations due to social and personal expenses and benefits, which are described below.

**Causes of divergences between social and private costs and returns** – According to **Pigou**, free from the restrictions of ignorance and rigidity, there is equality in personal and social expenses and results. But some commercial behaviour give rise to rigidities by which changes are produced in personal and social expenses which through changes, tastes, business highs and lows, war and new business become more detailed. After obtaining external economies and diseconomies, there is difference in private product and social product by which deviation is found in social and personal expenses and profits. Now we will analyze these external economies and diseconomies.

1. **External economies of production:** When any firm without using the benefit and cost of any service provides the benefit and cost of same service to some other firms, then this is the external economies of production. Because of the lack of average cost of one or more firms, the external economies of production are obtained by other firms for their activities. The external economies of production are obtained when it becomes possible for one firm to obtain for other firms' trained labour, raw material, etc. at low rate. Under all these conditions, social marginal profit is more than the personal marginal profit and personal expenses are more than social expenses. This is because the firms that do the transmission do not ask anything from other firms for the expenses and benefits.



Notes

2. **External diseconomies of production:** External diseconomies of production bring changes in personal and social expenses and benefits when the production of any service or commodity by a firm has a significant effect on other firms in business. The example provided by **Professor Pigou** regarding air-pollution clarifies these differences. Assume that a factory is situated at a rich populated area and produces smoke. The smoke emitted from the factory spoils the health, house, household items, and clothes. As a result of this, the residential expenses increase several manifolds like washing the clothes, cleaning the household goods and cleaning the house and health expenses. These are social costs for which the factory never compensates the residents and thus gains. Thus, personal costs are less than social costs and the benefits of factory are more than social benefits because the owner of the factory escapes from the work done by the residents and therefore earns personal profit. Thus, in comparison to personal costs and benefits, social costs are more and benefits are less.
3. **External economies of consumption:** External economies of consumption are obtained from the delight of different consumers' anti-market correlation. An increase in the consumption of commodity or service, which impacts the structure and desire of consumption of other consumers, is external economies of consumption. When a person buys a television set, then the contentment of his/her neighbours increases when they and their children watch various programmes. This is an example of external economies of consumption where social benefits are more than personal benefits and social cost is less than personal cost because the owner of the television set does not earn anything from the neighbours – nothing is gained in lieu of watching programmes.
4. **External diseconomies of consumption:** When a commodity or service used by a consumer has a significant effect on the structure and desire of the consumption of other consumers then it is external diseconomies of consumption. Diseconomies of consumption, in particular, are produced from clothing related to fashion and consumer goods. When a rich lady in a locality follows a new style of dressing then the old style of dressing is not only criticized by this lady but also by other ladies who try to imitate the style of dressing followed by the rich lady. This way the social costs are more than the personal costs and social benefits are less than the personal benefits. Those people who are not capable of adopting the consumption structure of their rich neighbours often experience the emotions of displeasure and envy as a result of which their productive ability is minimized and the social and personal costs and benefits see lot of differences. Another example is the noise nuisance created from loudspeakers.
5. **Public goods:** Differences in the social and personal benefits could be because of public goods which have been condemned by **Pigou**. **Professor Baumol** has defined public goods as something which when used by one person does not minimize the values of the commodity for another person. The consumption of public goods is equal. Some of the services provided by the government like national security, security of people, judiciary, disease control, etc. are public goods. Their benefits are undivided. This is available to each person irrespective of whether they give anything for this or not. That is why they do not come under exclusion principles. Another feature of public goods is that their benefits are available at zero margin cost. That is their benefits can be provided to anyone without any additional cost. For example, the cost to provide justice does not increase when another person demands justice from court. The third feature of public goods is that they bring changes in external and social and personal benefits. Externalities are produced when one person provides public goods then he provides benefits to other people and thus produces social benefits which is more than the personal benefits. For example, when a person, by taking initiative, sets up an electricity pole in the street near his house, then all other residents gain from it. As a result of this, the social benefit is more than the personal benefit.

## Self Assessment

## Notes

State whether the following statements are True/False:

9. According to **Pigou**, due to external effects there is no maximum social welfare.
10. Compared to personal costs and benefits, social costs are more and profits are less.
11. **Pigou** does not consider national benefit as an indicator of welfare.
12. Like **Pigou**, **Bomol** suggests that by the method of taxes and subsidy, external effects can be controlled.

**Remedial measures – Pigou** preferred state interference to bring equality in personal and social costs and benefits. **Pigou** suggests introducing taxes, economic assistance, and other social control measures to stop the differences in the cost and benefit that occur because of production and consumption externalities. We describe this below:

1. **Social control measures:** Primarily, **Pigou** suggests social control measures to obtain ideal output or optimum welfare. According to him, national benefit would be more if the value of social net product is equal to the every possible experiment. If the price of social net product of factor is less than a practice to the other then the national income benefits can be increased by transferring the factors. This is possible only by social control. For example, the government can provide adequate facilities to factory emitting smoke and then ask the factory owner to move the factory out of the residential area. By doing so, the differences in social and personal costs and benefits produced from the smoked nuisance are free from state interference. Regarding consumption diseconomies, the state, by restricting the use of loudspeakers for important events, can stop the noise. In monopoly situation, **Pigou** was in favour of any types of nationalization or social control.
2. **Taxes and subsidies:** Apart from this to end the differences between social and personal cost and benefits, **Pigou** suggests the use of taxes and subsidies. According to him, the state can impose taxes on external diseconomies of production and consumption. For example, the government can impose taxes on each family and then provide the collected amount to the factory owner to make him move out of the residential area. In the condition of external diseconomies of production, by providing financial assistance to the state consumers, the national benefits can be increased so as to achieve an ideal production. By providing tax relief to consumers, the government can increase the consumption ability of the consumers and thus helps in maximizing their desires.

This is described by the curves of demand and supply. A demand and supply curve of a complete competitive market can only describe the visible personal benefits and cost but not the externalities. Externality exists if the full competitive market will not provide a socially optimal level. The government by imposing taxes and paying subsidies can internalize the externalities. Assume that social benefits are more than personal benefits which indicate negative externalities. In such cases, there is over-production of commodities that are required in society. To minimize this **Pigou** suggested imposing taxes on commodities. This is shown in Fig. 24.1 where D and S are, respectively, demand and supply curves. They intersect at E point and produces OQ. Curve S includes the cost of the commodities used by the consumers. This does not include negative externalities. When market supply curve S becomes identifiable and internalized the supply curve  $S_1$  is created. Now, curve D intersects curve  $S_1$  at point  $E_1$  and  $OQ_1$  production is fixed which is less than OQ. This is the social limit of production. On imposing taxes on consumers' commodities per unit T, the production of commodity will become less from OQ to  $OQ_1$  which will decrease the negative outputs of OQ production. Thus, over production will be ended and social and personal benefits will be equal.

When personal benefits are more than social benefits then these are positive externalities. In such cases, there is less production of commodities, as required by society. To increase this, **Pigou** has suggested providing per unit subsidy for the commodities of the consumers. This is shown in Fig. 24.2 where D and S are, respectively market demand and supply curve. This

Notes

intersects at point E and produced OQ. But this is not the optimum social limit of production. To encourage the production of commodity from which positive externalities are obtained, the government provides the consumer subsidy equivalent to B by which the demand curve D moves upwards and becomes  $D_1$ . By this, the quantity of the produced commodity increases from OQ to  $OQ_1$  which is the social optimum limit. Thus, to bring equality in social and personal costs and benefits, tax and subsidies are effective measures.

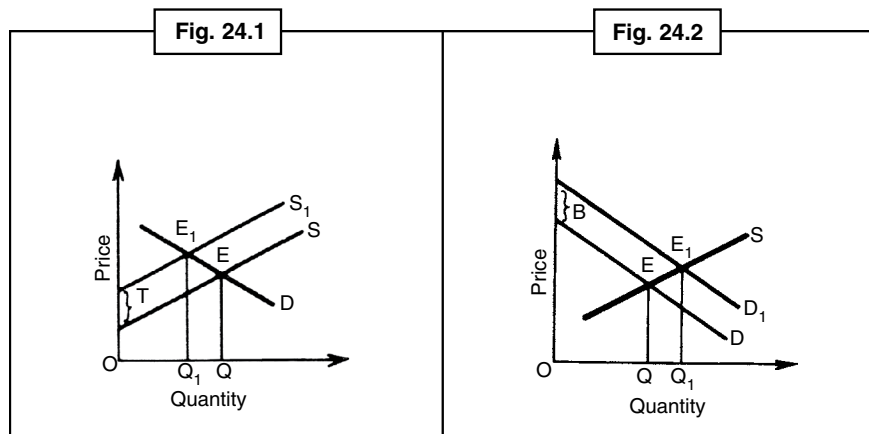

3. **Public goods:** If the number of probable consumers of a public goods is more, then only with the assistance of public authority can the commodity be distributed among consumers. Because the benefits of common commodities are undivided, the government should adopt such measures that the cost of common commodities can be distributed among public so that each person can use it and thus lead a better life. Apart from this, if the probable benefit of public goods is greater than its cost, in which the government's imputed cost of expanding the workable is mixed then this, is within law of social welfare in the area of public activity.
4. **Unitization:** Another measure is amalgamation of externalities in production. When the firms are established in oil production in the same area, then drilling and pumping are done from it from which there are diseconomies of production. With the merger of firms and without the production diseconomies, oil can be produced very effectively.
5. **Property rights:** Prof. Ronald Coase has stated that the main source of externalities is the inappropriate assignment of the property rights. According to him if property rights are clearly defined then the affected person would adopt principle for amalgamation of externalities. Therefore, it is necessary that property rights are marketable so that personal dealings can be done. According to him the market may be goes into **Pareto Optimum**.

*Did u know?* Economic equality makes greater to the welfare.

### 24.4 Pigou's Concept of Ideal Output

Pigou's concept of ideal output is related to the highest level of welfare in economic methodology. By Pigou the national dividend is considered an indicator of welfare. According to Pigou, when the price of marginal social products is equal in all possible uses, then the national profit gets maximum. Where there

is complete contest, the scenario of superior or ideal output is created. But, contrary to other experiments, in any one experiment if the value of marginal social output of institutions is less, then the unique product can obtain by changing more profitable factors through social restriction and taxes and subsidies.

**Professor Baumol** has given new description to **Pigou's** concept of ideal output and related it to **Pareto's** complete control. According to his definition, ideal output is that on which there can be no re-division of various experiments of economic institutions which can take society, compared to previous state it was in, to a better place. The definition of this ideal output is similar to that **Pareto** condition according to which welfare is maximum when through any economic regrouping the condition of one person, without changing the situation in the other, can be made better than it was earlier.

**Baumol** has described the problems of ideal output in the dictionary of modern analytical tools of economic welfare. His analysis is based on following assumptions—(1) there is competition in the demand for readymade goods in market. (2) There is proper distribution of all goods in the society. (3) Taste and technology never change in society. (4) Every person in a society gives preference to the maximum volume of the product and not the least volume. (5) The limit of placement of institutions is given. (6) There are no external effects of consumption and output. (7) The indifference curves do not intersect each other. (8) In economics, only two goods, X and Y, are produced.



Task

Please state your thoughts on **Pigou's** concept of ideal output.

When these assumptions are provided, **Baumol** has proved in graphical form how a society reaches a situation of ideal output. Just concentrate on Fig. 24.3. In this figure, the production of object X is measured on horizontal axis whereas the production of object Y is measured on vertical axis.  $I_1$  and  $I_2$  are indifference curves which show the various coincidences of objects available to society. On any point the indifference curve shows the gradient of the objects between X and Y the rate of substitution ( $MRS_{xy}$ ). TC is a pictorial curve that, using available institutions and technology, shows various production co-incidences. A gradient of transfigurational curve on any point proportionally measures the social marginal cost (SMC) of X from the social marginal cost of Y. The gradient of transfiguration curve, in our example, is marginal rate of substitution between X and Y. This value line of  $MRT_{xy}/MSC_x/MSC_y$  is PL whose gradient makes  $P_x/P_y$  appear.

On point E, the society achieves a state of ideal output where transfiguration curve TC touches the highest possible group curve  $I_1$ . On this highest level, the society produces and consumes object  $OX_1$  of X and  $OY_1$  of Y. If there is any other speed other than point E on curve TC then would appear compared to group at much less indifference curve, like the I curve, and compared to welfare may appear at lower limit.

It can be proved that this ideal output is actually a competitive output. Because the belief is that there is total competitiveness and there is lack of external effects; therefore in the entire market the price of both commodities remains same. Thus from the demand side, control is exercised on point E where the value line PL touches the marginal curve  $I_1$ . Thus on point E.

$$MRS_{xy} = P_x/P_y \quad \dots(i)$$

From the supply side, it is essential, for competitive control, that the gradient of value line is certainly equal to the gradient of transfiguration curve, that is

$$P_x/P_y = MRT_{xy} \quad \dots(ii)$$

In the complete market,  $MRT_{xy}$  marginal personal cost of  $MC_y$  of Y is equal to the rate of marginal personal cost of  $MC_x$  of X. Because it is assumed that there is no effect in production and therefore marginal personal cost of production is equal to marginal social cost of production. Thus, the transfiguration curve says

$$MRT_{xy} = MC_x/MC_y = MSC_x/MSC_y$$

**Notes**

The output of (i) and (ii) states that competitive production is fixed at that place where value line and indifference curves are mutually tangent that is  $MRT_{xy} = P_x/P_y = MRT_{xy}$  this is point E on Fig. 24.3. Actually, this competitive control is **Parotean** complete control or **Parotean** optimization. But ideal output is fixed at that place where transfiguration curve touches indifference curve. However, it is in the absence of external effects that the situation of competitive production and ideal output is same, which is shown as E in Fig. 24.3.

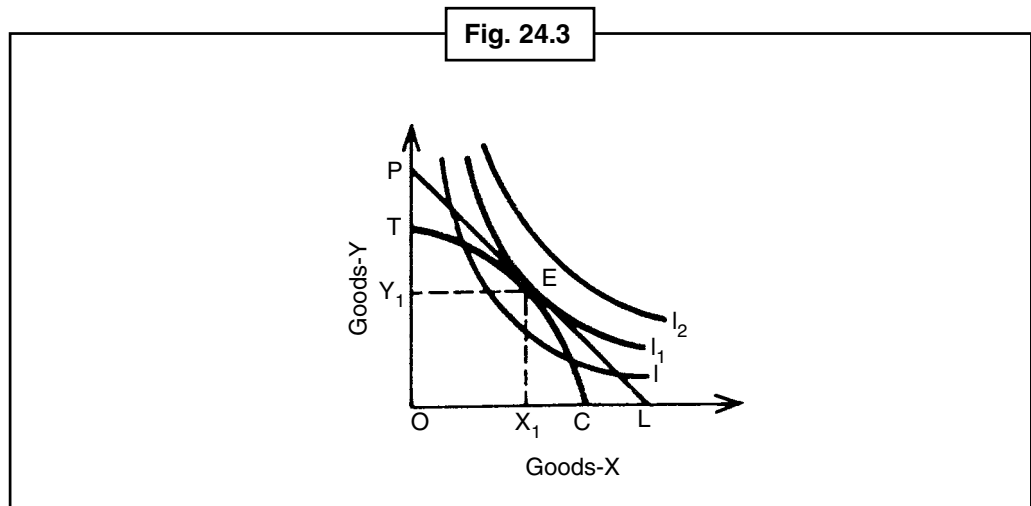

But if those who produce commodity X exist in business by external effects, then their marginal social cost will diverge from the marginal personal cost. Thus in this business, the average of marginal social cost and producers of commodity Y will not equal. In other words, transfiguration curve and value line are mutually not tangent.

First think of that situation where external effects are found in the production of commodity X. To control production, the required value line is shown as *bb* line in Fig. 24.4. The gradient of this line is more than the gradient of curve TC which means that the marginal personal cost is more than marginal social cost. Now think that external effects exist in the production of commodity X. Value is shown as *dd* line whose gradient is less than the gradient of transfiguration curve. Here compared to marginal personal cost, marginal social cost is more.

In the lack of external effects, point E is the point of ideal output where indifference curve  $I_1$  and transfiguration curve TC touch each other. This is what the situation is for competitive production as well because value line touches to indifference curve  $I_1$  and transfiguration curve TC. If during the situation of external diseconomies of production, commodity X is produced then control point is B which is to the right of E. Here value line is tangent to point B of indifference curve I where commodity X will be produced and therefore the control point is D which is to the left of E. Here value line dd touches indifference curve at point D where the output of commodity X  $OX_2$  which is comparatively higher than its ideal output  $OX$ . Point B and D cannot be ideal output as they comparatively are placed below at indifference curve whereas point E is comparatively placed above curve  $I_1$ .

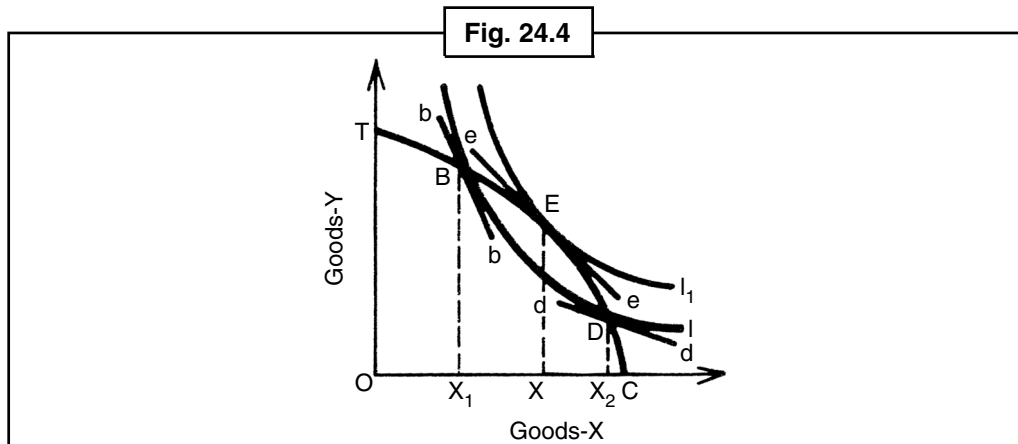

Like **Pigou**, **Baumol** suggests that external efforts can be rectified through the methods of tax and subsidies and ideal output can be achieved. If the output of commodity X is more than the ideal output like on point D then by imposing heavy taxes on each unit of output, the output can be reduced. On the contrary, if the production of commodity X is less than ideal output as on point B, then by giving subsidy for each unit of output, we can increase the output. We can achieve ideal output only when the amount collected as tax can equal the subsidy paid by the government.

## 24.5 Summary

- To maximize the welfare, the distribution of national income is significant. If national income is fixed then transfer of income from rich to poor will further the welfare. According to **Pigou**, such transfers have less impact on rich compared to poor as a result of which the economic condition of poor improves. The condition of welfare is based on **Pigou's** dual concept "equal capacity for satisfaction" and "Diminishing marginal utility of income".

## 24.6 Keywords

- **Dual Criterion:** Two types of principles
- **External Effects:** Outer Effect
- **Over Production:** More Production
- **Unitization:** Process of being one

## 24.7 Review Questions

1. What are **Pigou's** welfare concepts? Explain.
2. Comment on external economies of production.
3. What are the measures of social restriction proposed by **Pigou** to obtain ideal output or highest welfare?
4. What do you understand by **Pigou's** concept of ideal output?

Notes

**Answers: Self Assessment**

- |                |             |            |          |
|----------------|-------------|------------|----------|
| 1. A. C. Pigou | 2. Pleasure | 3. Welfare | 4. (a)   |
| 5. (c)         | 6. (b)      | 7. (a)     | 8. (a)   |
| 9. True        | 10. True    | 11. False  | 12. True |

**24.8 Further Readings**



*Books*

1. **Microeconomics: An Advanced Treatise**—*S.P.S. Chauhan, PHI Learning.*
2. **Microeconomics: Behaviour, Institutions and Evolution**—*Sampool Bowels, Oxford University Press, 2004.*
3. **Microeconomics: Principles, Applications and Tools**—*Sanjay Basotiya, DND Publications, 2010.*

## Unit-25: The Social Welfare Function

### CONTENTS

Objectives

Introduction

25.1 Bergson's Social Welfare

25.2 Summary

25.3 Keywords

25.4 Review Questions

25.5 Further Readings

### Objectives

After studying this unit, students will be able to:

- Know about Social welfare function.
- Explain the criticism of the social welfare function.
- Discuss the equation of social welfare function.
- Study the majority rule.

### Introduction

**Prof. Bergson** presented the theory of social welfare function for the first time and later **Samuelsson**, **Tintner** and **Arrow** have further developed this theory. Their opinion is that without adding value judgments, there cannot be any meaningful propositions in welfare economics. The concept of social welfare is an attempt to present the idealistic study of welfare economics from scientific view.

### 25.1 Bergson's Social Welfare

Social welfare function represents those factors on which welfare of society is assumed to be dependent. According to the definition given by **Bergson**, it is "either function of welfare of each individual of the community or is the function of goods consumed by each individual of the community and services rendered." In its original form, **Bergson** has presented social welfare function in an ordinary way. "This is that function which relates social welfare and all those possible variables which affect welfare of each individual like services and consumption of each individual. It can be assumed that "it is each individual's welfare function which successively depends as his personal evaluation of relation between that individual's own best state and distributed welfare among all members of the



**Notes** community.” Thus, social welfare function is the function of ordinary numerical indication welfare of the society and individual ability. This is represented as:

$$W = F (U_1, U_2, \dots, U_n).$$

**Self Assessment**

**Fill in the blanks:**

1. Theory of Social Welfare function is presented primarily by .....
2. Social welfare function theory is further developed by **Arrow , Tintner** and .....
3. The concept of social welfare is an attempt to present idealistic study of .....



*Notes* Social welfare function represents those factors on which welfare of a society is assumed to be dependent.

Where *W* is economic welfare of the society, *F* function is from  $U_1, U_1, \dots, U_n$  as 1, 2, ..., *n* level of using the individuals. *W* is increasing function of these utilities.

Weighing products on both axes drawing, well behaved social indifference curves series, social welfare function can be represented on figure. Every indifference curve represents different distributions of utilities among those individuals, whose level of social welfare is equal. These curves help the policy makers in knowing that whether a particular economic policy will lead to progress or not. If any single change can take individuals to a more high indifference curve position, then it is assumed that there is an increase in social welfare.

**Self Assessment**

**Multiple choice questions:**

4. **Bergson’s** social welfare function is based on some definite ..... .  
 (a) assumption      (b) narration      (c) rituals      (d) none of these
5. The concept of social welfare is an attempt to present ..... study of welfare economics by scientific view.  
 (a) idealistic      (b) communist      (c) economically      (d) none of these
6. Every welfare curve presents the ..... social welfare.  
 (a) base      (b) economical status      (c) level      (d) none of these
7. According to Bergson’s theory, the social welfare depends upon the money and ..... .  
 (a) Capital      (b) Level      (c) Income      (d) None of these

Social welfare function is explained in Fig. 25.1.  $FF_1$  is utility frontier, which expresses the boundary of all possible utility combinations derived from given function of the economy. It enters when many utility possibility curves covered on another. In Fig 25.1, *W*,  $W_1$  and  $W_2$  expressing the social welfare function are family of curves. Each welfare curve expresses the focus of welfare combination of utilities of two persons A and B, for which both the individuals are indifferent. Every welfare curve shows the level of social welfare. Welfare curve  $W_1$  shows higher level of social welfare than *W* and  $W_2$  shows higher level of social welfare than  $W_1$ . Maximum social welfare or optimum situation is that where utility frontier  $FF_1$  touches welfare

curve  $W_1$ . In the diagram, point E clearly shows the maximum social welfare state or Bliss point. Constraints of given technology and fixed quotation of inputs whatever with the given technology and constraints of fixed quantities of inputs with society whatever the welfare combinations are obtained E is the maximum society values. Point L lies the lower welfare curve  $W$  and expresses low level of social welfare where point C situated in  $W_2$  is outside utility frontier of society  $FF_1$ . So the point E expresses the maximum social welfare.

Notes

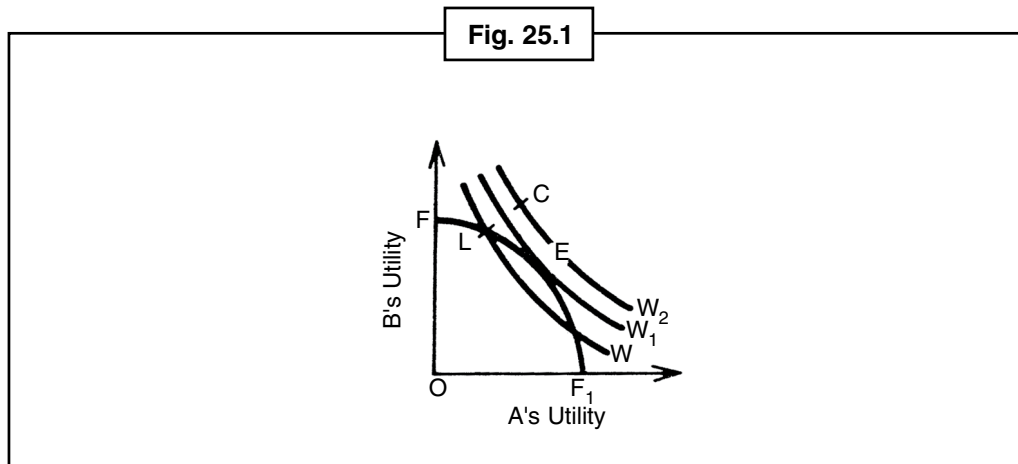

*Did u know?* Social welfare function is the function of ordinal numerical indication of social welfare and individual utility.

**Its Assumption** – Bergson’s social welfare function is based on some assumptions –

1. This theory assumed that social welfare is dependent on income and capital of every individual and welfare of each individual depends on his personal property and income as well as the distribution of welfare of the members of the society.
2. It acknowledges the presence of outer economy and diseconomy and their effect in present.
3. It is based on ordinal numeric ranking of combinations of variables affecting the individual welfare.
4. In this function, the interpersonal comparisons of utility, in which price decision includes, are found.

**Its Criticisms** – With these assumptions, the social welfare function according to **Prof. Samuelson** “becomes as broad and empty as essential language.” Other economists welcomed it as “major contribution in welfare economics”, where the opinion of **Dr. Little** “completes formal mathematical settlement of welfare economics.” **Sketovosky** believes it as “totally ordinary” and his aim is to identify the formal and rigorous restatement. For instance incorporating of social welfare function can remove the uncertainty found in Pareto Optimum. But this function has also some limitations.



*Task* Expresses your views on Bergson’s social welfare.

## Notes

1. **No relation to practical policy:** Dr. Little comprehends it as impractical in totalitarian state and it is also the more impractical in democratic state “where there are many faded social welfare functions as per their member. It can be accepted as essential formal factor for a general independent adjustment of the welfare which has no relation with the practical policy.”
2. **Difficult to construct social welfare function:** One more difficulty arises in the construction and shape of welfare function. On adding the preference of each individual, social welfare function is constructed. But the problem is individual preference should be given equal weight of different. It makes a hard talk to create a social welfare function.
3. **Equations and curves arbitrary and imaginary:** Representation social welfare function in equations or social indifference curves does not help in solving the problem as individual welfare function cannot be estimated. Thus all the equations and curves representing social function are arbitrary and imaginary.
4. **Without empirical significance:** According to **Dr. Little** the concept of maximum is without any possible empirical significance, so it would be better not to use it at all. It is more meaningful to derive the optimum conditions in adequate state without trying to define a maximum situation.
5. **Not possible to construct social welfare function based on individual preferences:** Prof. Arrow described that if individuals has to choose from two or more alternatives then constructing social welfare function, the basis of ordinal member preference had to mutually oppose results. Suppose there are three persons, A, B, C, who are to choose from these possible social situations X, Y, Z members 1,2, 3. The obtained statistics are shown in Table 25.1. A will give preference to X as compared to Y, and to Y than Z, so he gives more preference to Z in comparison to X. B prefers Y than Z, Z than X and so Y is preferred more than X. C prefers Z than X, Y so prefers Z in comparison to Y. If individual preferences are given equal significance, then on the basis of majority rule, social function can be constructed. But majority rule leads to mutually opposing results. Two person (A and C) give preference to X more than Y and two persons (B and C) give more preference to Z than X. It clarifies the paradox of majority rule, which according to **Prof. Arrow** is deadlock and so creates undesired inaction in respect to socialization. Thus, the creation of a social welfare function is not possible, which considers preferences of every individual.
6. **Not helpful in solving the main problems of welfare economics:** According to **Prof. Baumol**, “social welfare function does not come and equipped with that kind of instructions, which is required for it.” Thus, the welfare is not very helpful to solve the main problems of economics.

## Self Assessment

State whether the following statements are True/False:

8. As per Dr. Little opinion, “The welfare completes the formal mathematical task of economics.”
9. One more difficulty arises in the construction and shape of creation of welfare function.
10. Incorporating social welfare function can remove the uncertainty found in Pareto Optimum.

## 25.2 Summary

- Social welfare function represents those factors on which welfare of a society is assumed to be dependent. According to the definitions given by **Bergson**, it is “either the function of welfare of each individual of the community, or the function of goods consumed and the services rendered by each individual of the community.”

### 25.3 Keywords

Notes

- **Bliss Point:** Point of much pleasure
- **Technology:** Technical

### 25.4 Review Questions

1. What do you understand by Bergson's social welfare?
2. The social welfare function is not possible by individual presence. Why?

### Answers: Self Assessment

- |                      |               |                         |         |
|----------------------|---------------|-------------------------|---------|
| 1. Professor Bergson | 2. Samuelsson | 3. From Scientific View | 4. (a)  |
| 5. (a)               | 6. (c)        | 7. (c)                  | 8. True |
| 9. True              | 10. False     |                         |         |

### 25.5 Further Readings



Books

1. **Microeconomics**—*Frank Cowbell, Oxford University Press, 2004.*
2. **Microeconomics**—*Robert S. Pindick, Daniel L. Rubinfeld and Prem L. Mehta, Pearson Education, 2009, PBK, 7th Edition.*
3. **Microeconomics**—*David Bosanko and Ronald Brutigame, Wiley India, 2011, PBK, 4th Edition.*

## Unit-26: General Equilibrium Theory

### CONTENTS

Objectives

Introduction

26.1 Problems of Existence, Stability and Uniqueness of General Equilibrium

26.2 The Walrasian General Equilibrium Model

26.3  $2 \times 2 \times 2$  Graphical General Equilibrium Model

26.4 Summary

26.5 Keywords

26.6 Review Questions

26.7 Further Readings

### Objectives

After studying this unit, student will be able to:

- Know Problems of Existence, Stability and Uniqueness of General Equilibrium.
- Study The Walrasian General Equilibrium Model.
- Understand Graphical General Equilibrium Model.

### Introduction

In this unit, you can learn The **Walrasian** General Equilibrium Theory, Graphical  $2 \times 2 \times 2$  General Equilibrium Model and the significance of general equilibrium, stability and uniqueness problems. Marginal equilibrium, general equilibrium and other equilibrium theories have included in the first unit of the book "Concept of Equilibrium".

### 26.1 Problems of Existence, Stability and Uniqueness of General Equilibrium

Problems of Existence, Stability and Uniqueness of General Equilibrium are included in general equilibrium analysis. It is described by the demand and supply curves of marginal equilibrium and the results are used in general equilibrium analysis.

## 1. Existence of General Equilibrium

The existence of General Equilibrium relates to the behaviour of sellers and buyers and how it affects the demand and supply curves. When demand and supply curves are equal on a positive price, this is equilibrium. This price is called Equilibrium Price. The demand and supply on this price is called Equilibrium Quantity. There is neither excess demand nor excess supply on equilibrium price. Symbolically,

$$E_D = Q_D - Q_S = 0$$

Where  $E_D$  is excess price;  $Q_D$  is quantity of demand and  $Q_S$  is quantity of supply. The excess price is that point where the demand curve intersects supply curve in a specific price. These curves should intersect each other in a positive price for existing of general equilibrium. The condition of general equilibrium is –

1. In this price, consumer gets full satisfaction as well as producer gets profit maximization.
2. All markets get empty on this price means the products are equally supplied and demanded in a market in a positive price.

## Self Assessment

### Fill in the blanks:

1. Problems of Existence, Stability and Uniqueness of General Equilibrium are included in ..... analysis.
2. The existence of General Equilibrium relates to the behaviour of sellers and .....
3. The quantity of demand and supply in a price is called .....

The Fig. 26.1 represents the general equilibrium, when the demand curve D intersects supply curve S on point E and OP is fixed price which is positive. This price equalizes the OQ quantity of demand and supply in market. This figure can be applied on market factor and product factor where the equilibrium comes at a time.

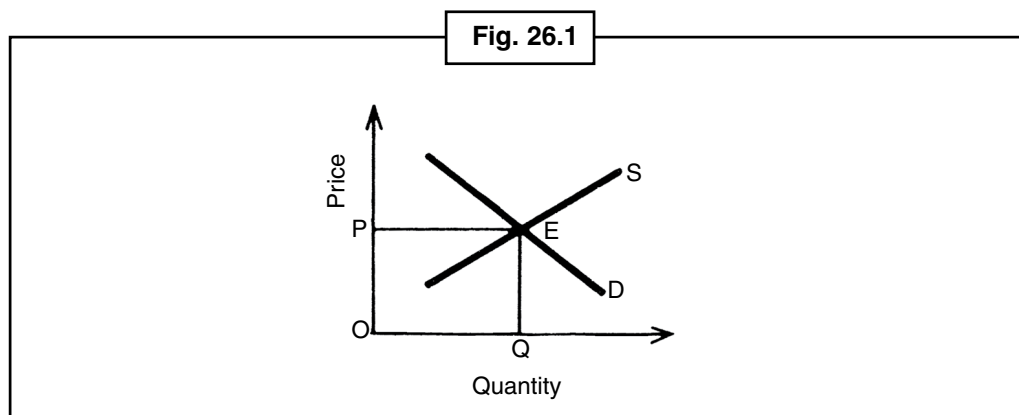

According to **Airo and Debro**, when in a perfect competitive market, the difference factor does not found then there general equilibrium exists.

Notes



Notes The existence of General Equilibrium relates to the behaviour of sellers and buyers.

## 2. Stability of General Equilibrium

The general equilibrium exists when the equalization of demand and supply dismissed and the excess demand or supply takes the demand and supply to its equilibrium state. Diagrammatically, when demand curve intersects supply curve from upward, then the general equilibrium happens. The equilibrium state is shown on Fig. 26.2 where D demand curve intersects S supply curve on point E which is equilibrium point. In OP equilibrium price, OQ product quantity is sold and bought. If the price falls from OP to  $OP_2$  then demand  $P_2d_1 > P_2s_1$  supply and  $s_1d_1$  is excess demand. Since demand is greater than supply so the price  $OP_2$  would come on equilibrium price OP. If price goes from OP to  $OP_1$  the supply  $P_1s > P_1d$  where  $ds$  is excess supply. Since demand is lower than supply so every seller will sell their product by decreasing its price. Thus, the competition in seller the  $OP_2$  price will come in equilibrium price OP. Thus, in OP price point E represents the equilibrium state.

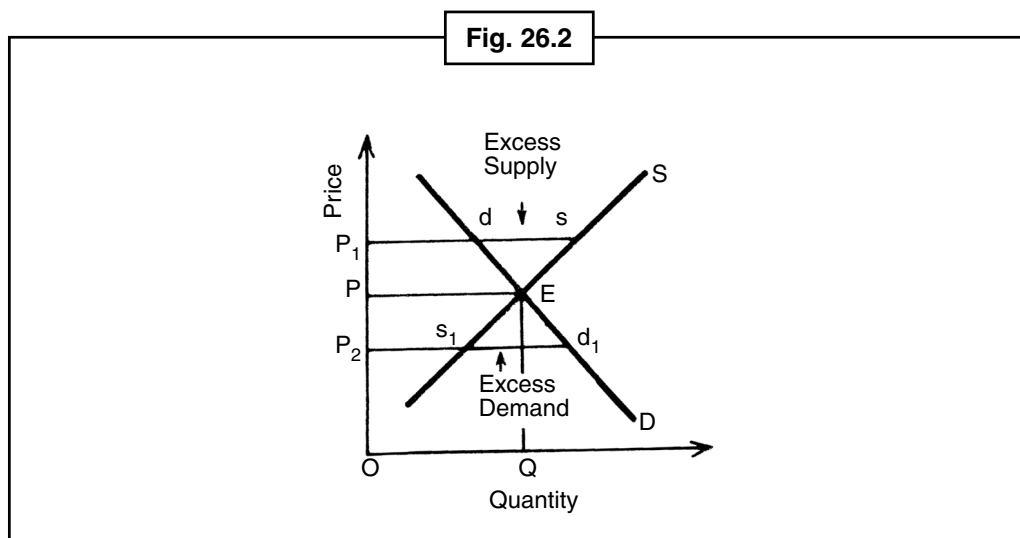

On the other hand, non-equilibrium is the state where the equilibrium does not exist if once changes. In geogramatical view, when demand curve intersects the supply curve downward then there is non-equilibrium stage. This is represented in Fig. 26.3 where D demand curve is upward slopping and cuts S supply curve in point E downward and OP is equilibrium price. If the price increases from OP to  $OP_1$  then demand is  $P_1d > P_1s$ . The price goes up when demand is greater than supply and the excess demand will not end even the price rises. This increases the problem because the equilibrium stage E never gain again. Similarly, the instability is found downstream. When price falls from OP to  $OP_2$  then  $d_1s_1$  is excess supply which again falls the price and thus, the equilibrium stage E never happens.

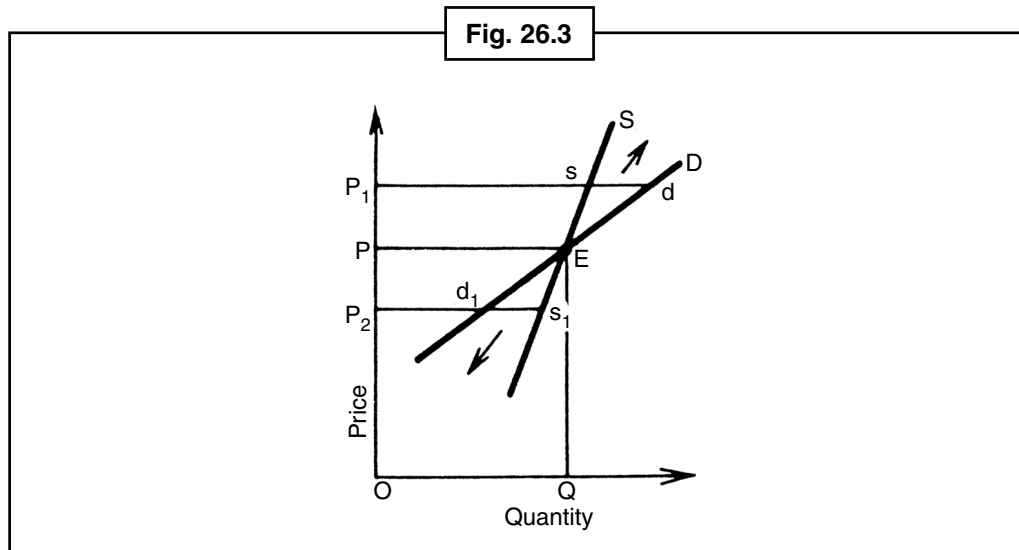

## Self Assessment

### Multiple choice questions:

4. When in a perfect competitive market, the difference factor does not found then there ..... exists.
 

(a) general equilibrium	(b) market equilibrium
(c) financial equilibrium	(d) none of these
5. One equilibrium comes when demand and supply curve equals ..... .
 

(a) in a negative price	(b) in a positive price
(c) in a general price	(d) none of these
6. Walrasian General Equilibrium needs market equilibrium ..... .
 

(a) never	(b) always
(c) no	(d) none of these

**Multiple Equilibrium** is also represents non-equilibrium as well as equilibrium stage. **Marshall** has proposed many equilibrium and non-equilibrium stages by the help of multiple equilibriums which is shown in Fig. 26.4. He describes, "The equilibrium of demand and supply depends upon the intersections of demand and supply curves."

The multiple equilibrium is shown in Fig. 26.4 where the demand curve  $DD_1$  and supply curve  $SS_1$  has 3 equilibrium curves A, B and C. Point A and C are fixed equilibrium. Point A is of fixed equilibrium because when the price goes up by  $OP_3$  then the supply is greater than demand. The competition to excess selling in sellers drops the price and equilibrium comes again on  $OP_3$ . If the price is lower than  $OP_3$  then the demand is greater than supply. The competition between sellers for lower supply, price again comes on  $OP_3$ . Thus point C is fixed. When price goes up from  $OP_1$  then the supply is greater than demand, the competition between sellers will lower the price on  $OP_1$ .



Notes

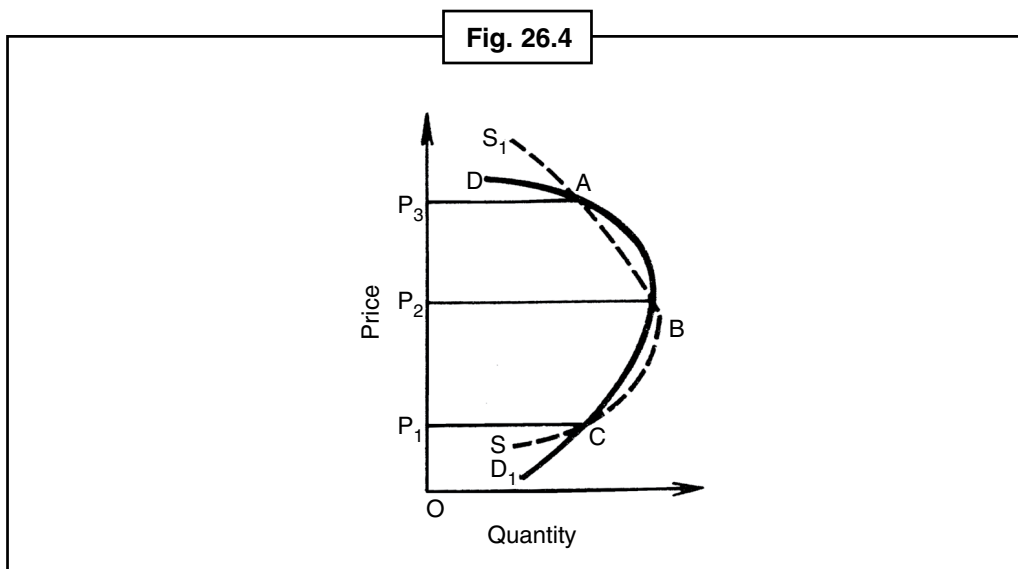

If price falls from  $OP_1$  then the competition between sellers will higher the price and price will come on  $OP_1$ . The point B is unstable equilibrium point. If price goes up from  $OP_2$  then there is excess demand and due to the competition of sellers the price will go up from equilibrium point. In other hand if price falls from  $OP_2$  then there is excess supply. The sellers will lower their price due to the competition to sell more till the point C does not get new equilibrium level.

Above analysis is based on **Marshall's** Equilibrium conditions. But in the view of **Walrasian**, the condition gets opposite in fixed and variable equilibrium. The equilibrium will be fixed where the demand curve cuts supply from upwards while equilibrium will variable where it cuts downward. So for Walras, the condition of A is fixed equilibrium, B is equilibrium and C is for variable equilibrium. This happens because the condition of fixed equilibrium of **Marshall** is based on price determination concept while Walras's Quantity determination concept.

Thus, in The **Walrasian** General Equilibrium the market is always in the fixed equilibrium. This comes by repetitive process. If there is variable equilibrium then every market will search for their equilibrium price. When this quantity price is repeat then the economical condition gets general equilibrium by groping as well as trial and error process. **Aero** and **Hurwitz** have shown that the **Walrasian** system is fixed while some economists have proved this variable. According to **Aero** and **Debro**, the **Walrasian** system is fixed when the factors of scale are decreasing or fixed, no changes in consumption and production and every product is gross substitute means by increasing one product's price, others get positive excess demand.

### 3. Uniqueness of General Equilibrium

When one set of quantity and price fulfils the conditions of equilibrium, then this is unique equilibrium. For example, the equilibrium is fixed and unique in Fig. 26.1 because only one price  $OP$  and quantity  $OQ$  comes stability in market which is unique.

The uniqueness of equilibrium can also be defined by the concept of excess demand. The excess demand ( $E_D$ ) is the difference between demand ( $Q_D$ ) and supply ( $Q_S$ ).

$$E_D = Q_D - Q_S$$

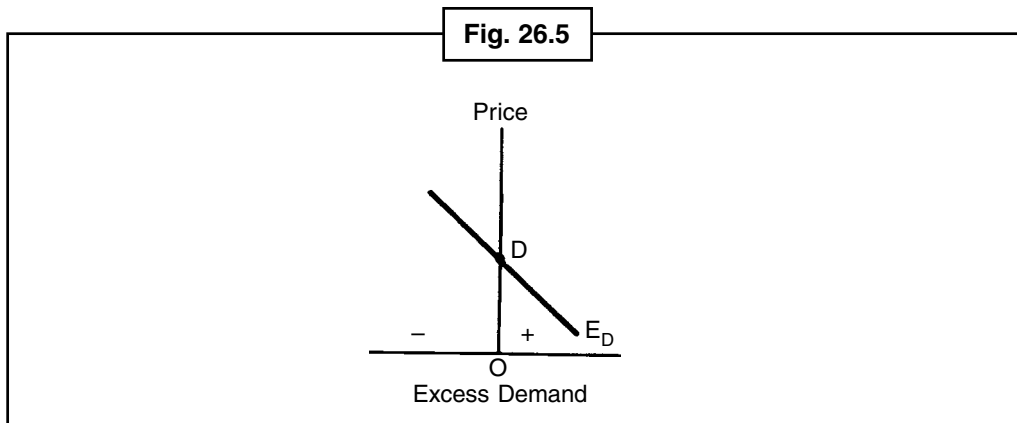

In geometrical form, the excess demand is shown by excess curve which is drawn by a price of the difference between demand and supply curve. For Figs. 26.2, 26.3 and 26.4, the excess demand curves are drawn until Fig. 26.5 to 26.7.

Let's take Fig. 26.2. When D curve intersects curve S on OP price then both the curves are in equilibrium on point E. The excess demand is zero here means  $E_D = 0$ . On that reason where D is greater than S ( $P_2d_1, P_2s_1$ ) excess demand is **positive** and where S is greater than D ( $P_1s, P_1d$ ), the excess demand is **negative**. The slope of excess demand curve is negative (downward from left to right) for general D and S curve means  $E_D < 0$ . When the slope of excess demand curve is negative on point after intersects the axis of price as shown in point D in Fig. 26.5, the equilibrium is fixed and unique.

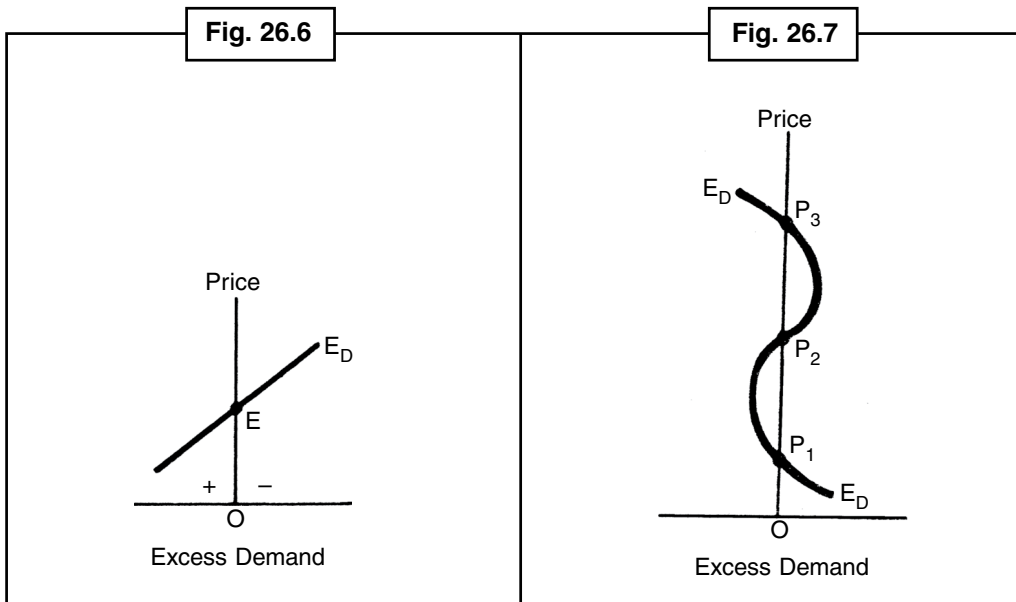

Now take Fig. 26.3 where demand curve intersects supply curve downward. The excess demand is positive below equilibrium price OP and above this, it is negative. So, the slope of excess demand will be positive, means  $E_D > 0$ . When the slope of excess demand curve is positive by intersecting the price axis, as shown in Fig. 26.6 on point E, then the equilibrium is variable and unique.

**Notes**

Figure 26.7 represents multiple equilibriums when it is drawn in basis of excess demand of Fig. 26.4. The curve  $E_D$  cuts the concave price axis on  $P_1$ ,  $P_2$  and  $P_3$  points which describe the multiple equilibriums. The slope of  $E_D$  curve is positive on point  $P_1$  and  $P_3$  while both equilibrium conditions are unique and fixed. But the slope of  $E_D$  curve is positive in point  $P_2$  which represents variable but unique equilibrium. To take the above analysis and uniqueness of equilibrium can rise until general equilibrium with relation of production and market and its dependencies.



*Did u know?* The quantity of demand and supply on price is called equilibrium quantity.

## 26.2 The Walrasian General Equilibrium Model

The French economist **Leon Walras** was the first who proposed a model of general equilibrium in his book **Elements of Pure Economics** in 1874. **Walras** has proposed that in every market, all the prices and quantities determines by affecting each other. **Walras** was used a system of equations for describing the functions of buyers in markets and told that the price of every related products and factors can be determine with this model.

### Its Assumptions

The Walrasian General Equilibrium Model is based on these following assumptions –

1. The product and factor are in perfect competition in market.
2. The interest of consumer is given and fixed.
3. There is no joint product.
4. There is no development.
5. There is no investment or disinvestment.
6. Factor of scale is fixed.
7. All units of a factor's service are equal.
8. The factors of production are in motion.
9. There is full employment.
10. There are no externalities in consumption or production.
11. Every product is substitute of each other.

### The Walrasian System or Model

If above assumptions are given, **Walras** has proposed a system by differentiating the correlate product market and factor service market. In product market, consumer buys products which are supplied by firms and they sell their services to the firms. Thus, the firms sell their product to consumer and buy factor services from consumers. Thus, there is a set of correlate dependencies of firms and consumers. The unknown variable in this system is the price and products of all services and products.

To describe the Walrasian Model, we are using the same sign –

$a, b, c \dots n$  represents the product.

$p_a, p_b, p_c \dots n$  represents the relative price of product.

$t, p, q \dots m$  represents the factors of production  $m$  for production of readymade product.

$p_t, p_p, p_q \dots m$  represents the price of factors of production.

To get rid from the complexity of capital, **Walras** used a product  $a$ , which he called numeraire and the price of all products are represented by this unit. The price of numeraire is  $p_a = 1$ .

The initial quantity ( $q_t, q_p, q_q \dots$ ) of factor service on given price ( $P_t, P_p, P_q \dots$ ), every consumer gets maximum satisfaction when the quantity of factor services ( $O_t, O_p, O_q \dots$ ) multiplied its price ( $p_t, p_p, p_q \dots$ ) equal to demanded quantity of product ( $d_a, d_b, d_c \dots$ ) multiplied its price ( $p_a, p_b, p_c \dots$ ). Thus the equation comes as –

$$O_t p_t + O_p p_p + O_q p_q + \dots = d_a p_a + d_b p_b + d_c p_c + \dots$$

This is budget equation.

Now we need  $m$  **individual demand equation for consumer** products which depend upon the price of one product and all other products which he can buy and on that price which he sells to firms for his services. This relation is represented by the following set of equation –

$$d_a = f_a(p_t, p_p, p_q, \dots, p_a, p_b, p_c, \dots)$$

$$d_b = f_b(p_t, p_p, p_q, \dots, p_a, p_b, p_c, \dots)$$

Now we create  $n$  **individual supply equation** for factor services.

$$O_t = f_t(p_t, p_p, p_q, \dots, p_a, p_b, p_c, \dots)$$

$$O_p = f_p(p_t, p_p, p_q, \dots, p_a, p_b, p_c, \dots)$$

By addition the above equations, we get –

(1) The market demand equation for  $m$  product is –

$$D_a = \sum d_a = F_a(p_t, p_p, p_q, \dots, p_a, p_b, p_c, \dots)$$

$$D_b = \sum d_b = F_b(p_t, p_p, p_q, \dots, p_a, p_b, p_c, \dots)$$

(2) The market demand equation for  $n$  factor service is –

$$O_t = \sum O_t = F_t(p_t, p_p, p_q, \dots, p_a, p_b, p_c, \dots)$$

$$O_p = \sum O_p = F_p(p_t, p_p, p_q, \dots, p_a, p_b, p_c, \dots)$$

When market demand equation for product is equal to market supply equation of services then Walrasian Market Equilibrium happens. Thus, from (1) and (2) we get –

$$D_a = O_t$$

And

$$D_b = O_p$$

Then in Walrasian system, the factor services should be equal to its supply quantity and the price of product should be equal to its average cost of production. These two conditions again give two sets –

1. The quantity of factor services should be equal to its quantity of supply for clearing the market for  $n$  factor service –

$$O_t = a_t D_a + b_t D_b + c_t + D_c + \dots$$

$$O_p = a_p D_a + b_p D_b + c_p + D_c + \dots$$

## Notes

2. The average cost of production is equal to the price of  $m$  product –

$$a_t p_t + a_p p_p + a_q p_q + \dots = 1$$

$$b_t p_t + b_p p_p + b_q p_q + \dots = p_b$$

Thus the equation is  $2m + 2n$ . No equation is independent because the budget equation needs to be equal for every human to satisfy this equation. We have left with  $2m + 2n - 1$  independent equation and this is equal to the number of unknown of determined-(1)  $n$  quantity of supplied factor services; (2)  $m$  quantity of demanded products; (3)  $n$  price of services and (4)  $m - 1$  price of product because  $p_a = 1$  is described.

Since the number of independent equations is equal to number of unknowns, so the Walrasian General Equilibrium model is fixed. But the equalization of number of independent equations and number of unknowns is not an essential condition for solution of model. This is not uniqueness and not an essential condition. This is because the Walrasian system is does not include the negative price of factor services and products and negative quantity of products and factors. In this model, we cannot determine absolute prices. So, the Walrasian Model is not determined because no equation is independent from equations which assume that there is low equations than low unknown as  $p_a = 1$ .

Walras has solved the problems of determination of general and fixed equation by using tatonnement and groping. Suppose that all sellers and buyers disclose the quantity which they want to sell or buy on prices. The business is an auction in perfect competitive markets. The auction man auctions the product and businessman tells the price. But the price and agreement are not happens until a set of equilibrium prices does not reach. If the demand is high for a set of any products then auction man increases the price of that particular product and lower the price if supplies more. They make this type of announcement until they do not reach in a price which makes equilibrium in general market. To sell and buy the production services, Walras has proposed that producer gives "tickets" by which they can buy a given quantity of services. These "tickets" tie temporarily to the producers and sellers. Only the price of all systems will come in equilibrium when the agreed price should be matched with equal demand and supply of services. Thus the Walrasian Model represents the determination of general market equilibrium and how it fixes.

**Its Criticism** – There are some limitations in Walrasian General Equilibrium along with determination problem.

**First**, it is based on many real conditions which are unreal in world. The perfect competition, which is based on this concept, never happens.

**Second**, this model is fixed. In this model, every producer and consumer, without wasting any time, consumes and produces fixed products. Their interests, preferences and economical decision are similar to each other. In fact, it never happens. The producer and consumer never think in a similar way and never work accordingly. The preferences and interests are always changed. The factors of scale never fixed and no two factors are equal. Thus the production cost of every producer is different. Since the condition, given by **Walras** has always changed, so the movement towards general equilibrium stops and nobody can achieve it.

**Last**, we cannot remove many concepts because the model of **Walras** is set of simultaneous equations which end in lack of those concepts. Thus this model starts with the base of equations which make it difficult. So the usefulness of this concept ends for normal student of economics.

### Self Assessment

**State whether the following statements are True/False:**

7. Diagrammatically, excess demand is shown by excess curve.
8. The French economist **Leon Walras** was the first who proposed a model of general equilibrium in his book *Elements of Pure Economics* in 1874.

9. There is no perfect competition in product and service market.
10. There is no externality of production or consumption.

### 26.3 $2 \times 2 \times 2$ Graphical General Equilibrium Model

Below we have studied a graphical condition of a static perfect competitive economy in which there are two consumers, two products and two factors. This is called  $2 \times 2 \times 2$  equilibrium model.

#### Its Assumptions

This model is based on following assumptions –

1. There is perfect competition in product and service market.
2. Labour and capital are two similar and completely divided factors of production. Both are available in fixed quantity.
3. Both the factors are in full employment.
4. Only two similar products X and Y are produced in economy. These products are available in limited quantity. The production equation of every product has given and does not change. Every production shows fixed factors of scale. There is MRTS with any Isoquant curve. It means that Isoquant curve is convex to its origin.
5. There is no externality of production.
6. There are two consumers A and B in economy which consume all quantities of X and Y. Every consumer has a set of convex indifference curves towards origin.
7. There is no externality of consumption.
8. Every consumer wants to maximize his satisfaction on a given income.
9. The consumer is owner of both the form of production.
10. Every firm (producer) wants to profit maximization on a given production equation.

On these given assumption, the economic is in general equilibrium state when two product markets and two factor markets, and two consumers and two firms individually are in equilibrium in a set. There are three characteristics of this general equilibrium model – (i) General Equilibrium of Exchange or Consumption (ii) General Equilibrium of production and (iii) General Equilibrium of Exchange and Production.



**Task** Give your views on Walrasian General Equilibrium Model.

#### (i) General Equilibrium of Exchange or Consumption

To general equilibrium of exchange, it is necessary that the marginal substitutional rate of two products should be equal and consumes both the products. It means MRS should be equal to its average price between two consumer products. Since in perfect competition, every consumer wants to maximize his satisfaction, so he will equal to his MRS to its average price ( $P_x/P_y$ ) for product X and Y. In this model, if there two consumers A and B, two products X and Y and on given price average  $P_x/P_y$ , the general equilibrium comes when consumer A selects X and Y like  ${}_A MRS_{XY} = P_x/P_y$  and consumer B selects X and Y like  ${}_B MRS_{XY} = P_x/P_y$ . So, the condition of general equilibrium for both the consumers:

$${}_A MRS_{XY} = {}_B MRS_{XY} = P_x/P_y.$$

**Notes**

The Fig. 26.8 represents the general equilibrium of exchange. Let's take two consumers A and B, they have quantity of product X and Y respectively.  $O_a$  is original point of consumer A and  $O_b$  is original point of consumer B (revert the diagram to understand). The horizontal lines of both the product  $O_a$  and  $O_b$  represent product Y and vertical line represents product X.  $A_1, A_2$  and  $A_3$  curves represent the indifference drawing of product A while  $B_1, B_2$  and  $B_3$  for B. Any points in this box represent the expected distribution of production between both the consumers. See point E where  $A_1$  and  $B_1$  indifference curves intersect each other. In this stage, A has  $O_a Y_a$  units of product Y and  $O_a X_a$  units of products X. B has  $O_b Y_b$  of Y and  $O_b X_b$  units of X. The MRS on point E is not equal to its price because the slope of curve is not equal. Thus the equilibrium exchange point E is not for product X and Y to A and B. But both have the base of exchange.

Suppose that A needs more of product X and B needs more of product Y and they come from E to R. A gets more quantity of X in point R, while B gets more quantity of Y on it. The condition of B does not change because he still on that indifference curve  $B_1$ , but A is in better condition on R because he steps ahead from  $A_1$  to  $A_3$  indifference curve. But if A and B both come from E to P then the condition of A remains same because he is still on that indifference curve  $A_1$ . Since B goes onto  $B_3$  so his condition gets better. They both in good indifference curves  $A_2$  and  $B_2$  respectively when they step from E to Q.

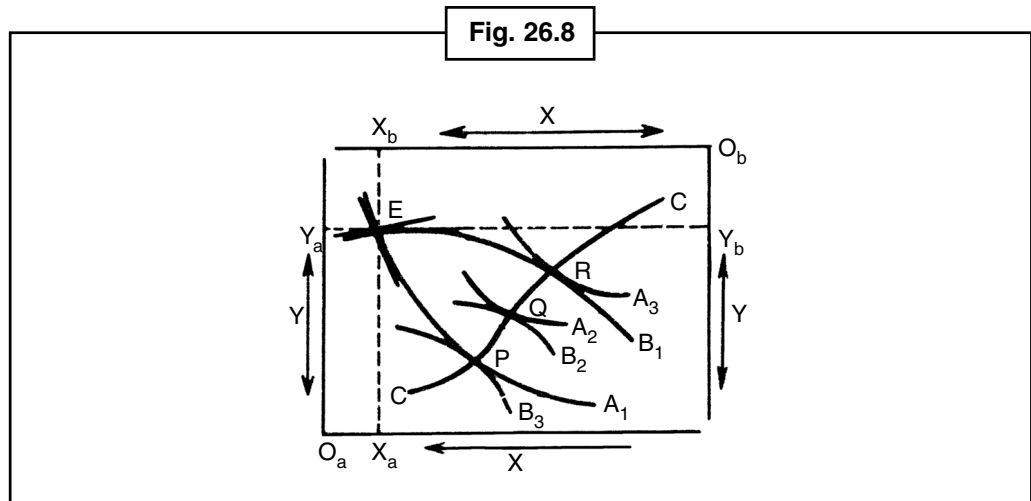

Thus, P, Q and R are three thinkable points in exchange. When these points are added by CC line, then contract curve has made. The general equilibrium of exchange will always on contract curve where  $MRS_{XY}^A = MRE_{XY}^B$ . This general equilibrium of exchange is not unique because it can happen in any point of contract curve.

**(ii) General Equilibrium of Production**

The general equilibrium of production comes when the MRTS between labour and capital of product X ( $MRTS_{LK}^X$ ) is equal to MRTS of the same of product Y ( $MRTS_{LK}^Y$ ).  $MRTS_{LK}^X = MRTS_{LK}^Y$ .

The Fig. 26.9 describes the general equilibrium of production. To produce two products X and Y, economy has limited two factors labour (L) and capital (K).  $O_Y$  is the original point of labour factor. Labour has indicated vertically while capital is on horizontal line with original point  $O_X$ . The vertical line  $O_X$  and  $O_Y$  represent product X and horizontal line represents to Y.

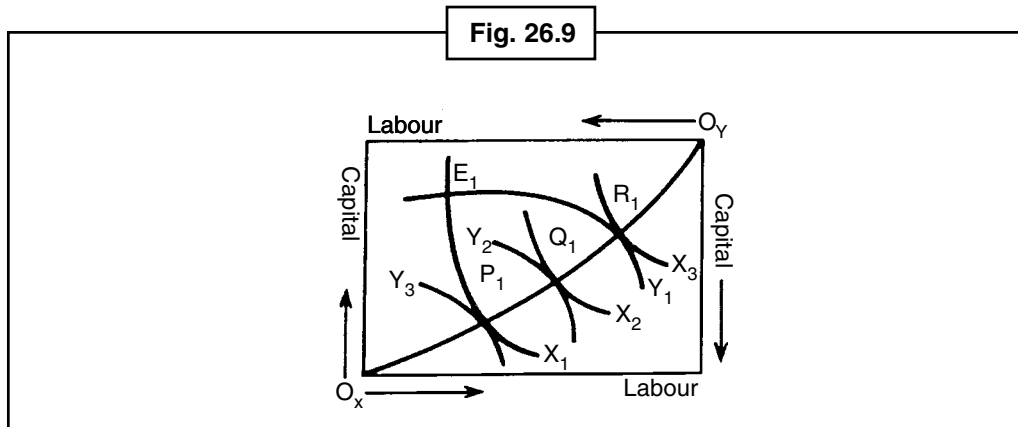

The production equation of every production comes from similar curves. The characteristics of it is fixed factors of scale and decrease MRTS. For product X, which original point is OX, has similar curves  $X_1$ ,  $X_2$  and  $X_3$  while for product Y, which original point is OY, has similar curves  $Y_1$ ,  $Y_2$  and  $Y_3$ . If initially the economical system is on point E then it does not maximize the production of X and Y because on point  $E_1$ , the slope of  $X_1$  is greater than  $Y_1$  -  $MRTS_{LK} > Y_1$   $MRTS_{LK}$ . To substitute labour for capital, firms will move from point  $E_1$  to either  $R_1$  or  $P_1$ . The production of one product will increase while another will be fixed. Thus to substitute labour and capital, firm can go to point  $Q_1$  and increase the production of product X and Y. The similar curve of product X is cogent to product Y on  $P_1$ ,  $Q_1$  and  $R_1$  and so it fulfills the condition  $X$   $MRTS_{LK} = Y$   $MRTS_{LK}$ . To conjugate these points, the contract curve  $O_X P_1 Q_1 R_1 O_Y$  is created. This shows all combinations of capital and labour which equalize  $X$   $MRTS_{LK} = Y$   $MRTS_{LK}$  on contract curve. But this general equilibrium of production is also not unique because it can happen on any point of contract curve.

The production related to contract curve  $O_X P_1 Q_1 R_1 O_Y$  from Fig. 26.9 is indicated as TC in Fig 26.10. This indicates the combinations of X and Y which can create by using fixed quantity of labour and capital. Concentrate on point P in Fig. 26.9.  $Y_3$  indicates 600 similar units of product Y and  $X_1$  indicates 100 units of product X. This has drawn as point P in Fig. 26.10. By adding points P, Q and R we creates expected production curve TC for product X and Y. If the labour and capital is fixed as well as technology, then economy cannot reach above TC curve. Also there is no economical point inside TC curve. So to maximize the production of X and Y, it is necessary to stable the economy on TC curve. In Fig. 26.10 the slope of any point on expected production curve indicates the MRT of X from Y. In other words, to produce an extra unit of product X by substituting capital and labour, how much production of product Y should less.

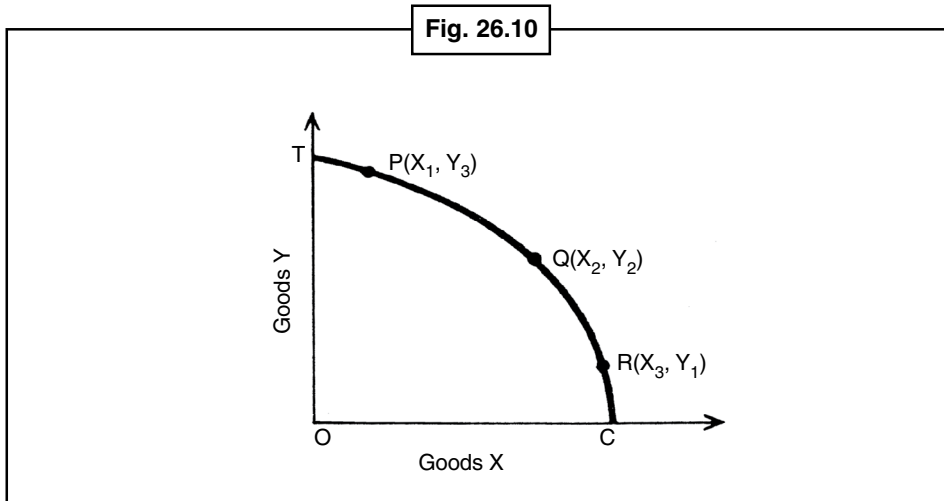



**Notes**

In perfect competition, the firm having profit maximization will be on production equilibrium when isorevenue line touches transformation curve. It means to get equilibrium of firm,  $MRS$  should be equal to its average price between both X and Y product— $MRT_{XY} = PX/PY$ . This law is demonstrated in Fig. 26.11.  $MRT_{XY}$  is measured on any point of transformation curve  $PP_1$ . TR is isorevenue line whose slope indicates  $P_x/P_y$ . The slope of transformation curve  $PP_1$  is equal to the slope of isorevenue line TR on point E. Thus,  $MRT_{XY} = P_x/P_y$ . Thus, every firm increases its production by producing and selling of  $OX_1$  units of X and  $OY_1$  units of Y.

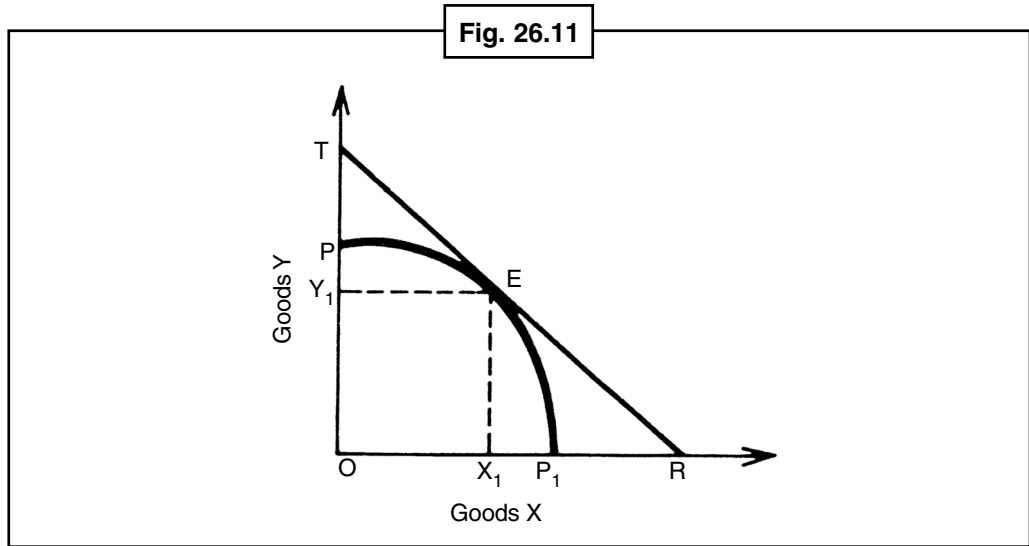

Actually, the for X MRT of Y is equal is ratio of marginal cost ( $MC_x$ ) of product X and marginal cost ( $MC_y$ ) of product Y. Means  $MRT_{xy} = MC_x/MC_y$ . But every firm produces the production where its marginal cost is equal to its market price. Thus for every firm  $P_x = MC_x$  and  $P_y = MC_y$ . So  $MC_x/MC_y = P_x/P_y$ .

**(iii) General Equilibrium of Exchange and Production**

Now we study general equilibrium of exchange and production under perfect competition. For this it is necessary that the  $MRS$  and  $MRT$  is equal between two products. Since the ratio of price of two products for consumer and firm is equal in perfect competition, so the  $MRS$  of all consumers will equal to  $MRT$ . Thus, both products will exchange and produce. Thus,  $MRS_{xy} = P_x/P_y$  and  $MRT_{xy} = P_x/P_y$ . So  $MRS_{xy} = MRT_{xy}$ .

The general equilibrium of exchange and production are shown in Fig. 26.12. TC is transformation curve for X and Y.  $MRT (MRT_{xy})$  shows by any point on TC curve for products X and Y, where production is in general equilibrium. Take any point Q on TC curve resulting the total production is OX and OY for X and Y respectively. This production determines an Adworth box dimensions for exchange. Drop the line from point Q to X and Y axis. Now O gets original for consumer A which names  $O_A$ . Thus Q is original for consumer B which names  $O_B$ . Since both the consumer has fixed preference so there is A and B indifference curve. Curve  $A_1, A_2$  and  $A_3$  represents indifference map of A and curve  $B_1, B_2$  and  $B_3$  represent indifference map of B. The tangent point of A and B is E, F and G. To mix these points, there is a transformation curve i.e.  $Q_A EFG O_B$ . On this transformation curve every point is equilibrium point for exchange where  ${}_A MRS_{xy} = {}_B MRS_{xy} = P_x/P_y$ .

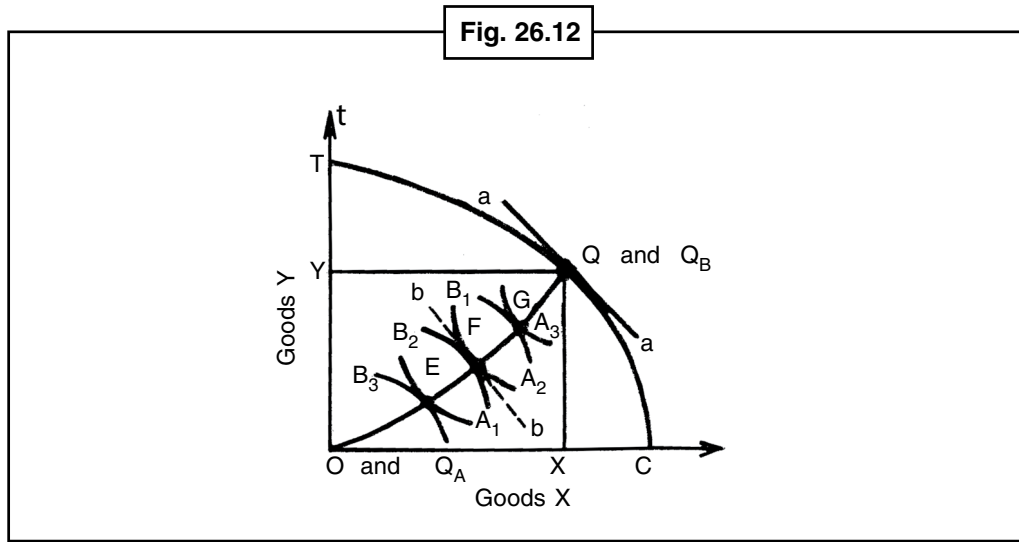

The equilibrium of exchange and production happen where  ${}_A MRS_{xy} = {}_B MRS_{xy} = MRT_{xy}$ . This happens when the exchange point F tangent *bb* is parallel to tangent *aa* drawn on curve TC of point Q. But this does not give unique solution. This is so because any tangent drawn on E or G can parallel to tangent *bb*.

### 26.4 Summary

- The existence of General Equilibrium relates to the behaviour of sellers and buyers and how it affects the demand and supply curves. When demand and supply curve are equal on a positive price, this is equilibrium. This price is called Equilibrium Price. The demand and supply on this price is called Equilibrium Quantity. The excess demand is zero on that price.

### 26.5 Keywords

- **Excess Demand:** More Demand
- **Excess Supply:** More Supply
- **Multiple Equilibrium:** Fixed and Variable Equilibrium.

### 26.6 Review Questions

1. What do you mean by existence of general equilibrium?
2. Write comments on The Walrasian General Equilibrium Model.
3. Describe the general equilibrium of exchange (consumption).

### Answers: Self Assessment

- |                        |            |                |         |
|------------------------|------------|----------------|---------|
| 1. General Equilibrium | 2. Sellers | 3. Equilibrium | 4. (a)  |
| 5. (a)                 | 6. (b)     | 7. True        | 8. True |
| 9. False               | 10. True   |                |         |

Notes

## 26.7 Further Readings



Books

1. **Microeconomics** – *Shipra Mukhopadhyay, Annie Books, 2011.*
2. **Microeconomics: An Advanced Treatise** – *S.P.S. Chauhan, PHI Learning.*
3. **Microeconomics: Behaviour, Institutions and Evolutions** – *Sampool Bowels, Oxford University Press, 2004.*

## Unit-27: Production Versus Consumption

### CONTENTS

Objectives

Introduction

- 27.1 Thoughts about Employment
- 27.2 Thoughts about Weakness
- 27.3 Production Limits the Consumption
- 27.4 Summary
- 27.5 Keywords
- 27.6 Review Questions
- 27.7 Further Readings

### Objectives

After reading this unit, students will be able to:

- Study the thought about employment.
- Know the thought about weakness.
- Explain production limits the consumption.

### Introduction

There are mainly two ideologies in economics. First, the economists of 19th century who think mainly about supply, which is related to production. In this, the main economists were **Adam Smith**, **David Ricardo**, **J. B. Say** and others. These economists mainly support to open market means no interference of government. Where the second ideology is of 17th century economists. This ideology was accepted by the 20th century economists who were called 'God of Economics'. The analysis of **Keynes** was mainly depended upon demand. Demand is directly attached with consumption. The analysis of **Keynes** was determined the consumption by demand in short time. Means to conclude we can say that one ideology supports supply i.e. production and second supports demand means consumption. It means both ideologies are different.



Notes Demand is directly related to consumption.

**Notes**

When human takes birth in globe, he has some basic necessities which comes from his desire and desire can be satisfied by consumption of product. **Adam Smith** has written in his book *Wealth of Nation* that economical process draws from money. However, the economists of 19th century thought that supply creates its own demand. In contrast, the economists of 20th century thought that demand creates its own supply. Means both ideologies are on different concepts.



*Did u know?* When human takes birth in globe, he has some basic necessities.

### 27.1 Thoughts about Employment

The economists of 19th century knew that if the supply is increased means people will get employment. If production is increased this will eliminate the unemployment problems. However, they regarded unemployment as temporary problem. Means unemployment can be omitted by decreasing rate of wages. In brief, they told that increase of production gives opportunity to people to get employment. In contrast, consumptionist means the economists of 20th century didn't like that theory. They thought that only expanding of production does not end the unemployment. They believed that more production creates crisis in a country. Means the production should be increased only of those products which are in demand. Means products should be supplied as per their demand. They thought that if production increases then unemployment will increase.



*Task* Give your views on Employment.

### Self Assessment

**Fill in the blanks:**

1. There are mainly ..... ideologies in economics.
2. Demand is directly depend upon .....

### 27.2 Thoughts about Weakness

Weakness means decrease in capital. After the Second World War, the consumption power of people was decreased. Productionists or the economists of 19th century thought that the investment of capital is the way of prosperity. While the economists of 20th century think that destruction of capital is the way of prosperity. Both ideologies support money. Because the economists of 19th century thought that the production can increased by investment of money and by this people can get employment and products. While the economists of 20th century think that capital can increase consumption and this helps to omit crisis and increment of employments. They supported big demand can omit the crisis.

**Self Assessment**

Notes

**Multiple choice questions:**

3. The economists of 19th century emphasizes..... .  
 (a) on supply      (b) on expenditure      (c) on buy      (d) to sale
4. The weakness means..... .  
 (a) shortage of money (b) physical shortage      (c) shortage to buy      (d) none of these
5. .... economists knew that supply creates its own demand.  
 (a) 20th Century      (b) 19th Century      (c) 18th Century      (d) 17th Century
6. .... economists knew that demand creates its own supply.  
 (a) 19th Century      (b) 20th Century      (c) 18th Century      (d) 17th Century

**27.3 Production Limits the Consumption**

Productionists means the economists of 20th century think that to care the children, parents expend and they expend on productive products. The market gets products by production and the production occurs for those products which are in desire. However, the supply of all desires is not possible. So production limits the consumption.

**Self Assessment****State whether the following statements are True/False:**

7. Demand is directly related to consumption.
8. The analysis of Keynes was mainly depends upon demand.
9. 'Wealth of British' is written by Adam Smith.
10. Production cannot possible without consumption.

**27.4 Summary**

By the above analysis it is evident that consumption and production is not opposite to each other but they are is directly proportional to each other. Because, if there is no consumption, production will not happen and if consumption is not possible without production.

**27.5 Keywords**

- **Production:** To create
- **Consumption:** Consumption

**27.6 Review Questions**

1. What do you mean by Production and Consumption? Explain it.
2. "Production limits consumption". Explain it.
3. Give your views on weakness.

Notes

**Answers: Self Assessment**

- |          |                |         |         |
|----------|----------------|---------|---------|
| 1. Two   | 2. Consumption | 3. (a)  | 4. (a)  |
| 5. (b)   | 6. (b)         | 7. True | 8. True |
| 9. False | 10. True       |         |         |

**27.7 Further Readings**



*Books*

1. **Microeconomics: An Advanced Treatise**—*S.P.S. Chauhan, PHI Learning.*
2. **Microeconomics: Behaviour, Institutions and Evolutions**—*Sampool Bowels, Oxford University Press, 2004.*
3. **Microeconomics: Principles, Applications and Tools**—*Sanjay Basotiya, DND Publications, 2010.*

## Unit-28: Economics of Risk and Uncertainty

### CONTENTS

Objectives

Introduction

28.1 Individual Consumer's Behaviours Towards Risk

28.2 Risk Preference: Attitude Towards Risk

28.3 Gambling

28.4 Summary

28.5 Keywords

28.6 Review Questions

28.7 Further Readings

### Objectives

After studying this unit, students will be able to:

- Know the individual consumer's behavior towards Risk.
- Explain about the gambling.
- Study about the insurance.
- Know about the assets portfolio selection.

### Introduction

Uncertainty is a factor of human life. So, there is risk in all financial transaction. Wherever, there is uncertainty, there is risk. This is important to know the difference between uncertainty and risk. Risk is a situation, in which the probability of an incident can be measured. On the other side, uncertainty is a situation, where the probability cannot be measured. So, here are one or more incidents in the situation of risk and the risk taker is aware about the all possible incidents and know about the probability of every incident. In the situation of uncertainty, we neither know the right nature of incidents nor can distribute the probabilities. There is uncertainty in the real life and in lots of objects and services, like the investments in share and stock, insurance and gamble etc. So, such decisions would be taken whose result cannot be known prior.

Before the analysis of the theory of risk, it would be beneficial to understand the assumptions that to be used in this experiment.



Notes



Notes    Uncertainty is a basic fact of human life.

**Probability**

The probability of an incident is the ratio of its occurrence (the frequency). It is the ratio of favourable incidents and total number of incidents. Suppose that there is a situation in which any one out of expected results. For example, when a dice is thrown then any one number may be 1, 2, 3, 4, 5 and 6.

For indication,

$$\text{Probability} = \frac{\text{Number of times incident has occurred}}{\text{Total number of possible incidents}}$$

Because turning the dice, it gives possible results 1, 2, 3, 4, 5 and 6, in which the related frequency is  $1/6 = 0.167$  of any number result that is the probability of every result.

In a special situation, if the all possible results are indexed for incident and the every result is distributed to the probability of incident. Then this is called the probability distribution.

For example, if a coin is tossed and the head is probable to come 0.6 and not to come 0.4, then this shows the total number of probabilities on the incident, if its occurrence or not occurrence is  $1 = (0.6 + 0.4)$ .

The index of every result of an incident and its probability is the probability distribution in the form of a table which is shown below –

<b>Table 1</b>	
<i>Event Toss of Coin</i>	<i>Probability of Occurrence</i>
The state of coming “top”	0.6
The state of not coming “top”	0.4
	1.0

The probable distribution value is necessarily 0 to 1. If the probability is  $P_i$ , then  $0 \leq P_i \leq 1$ , where  $i = 1, 2, \dots, n$ .



*Did u know?*    Where there is risk, there is uncertainty.

**Expected Value**

There are such statically measures for the probability distribution which mainly are available for the brief knowledge about the distribution. One of these is used the probable distribution, expected value or mean average, is the full average of the related value from the several results.

If two possible results are value of  $X_1$  and  $X_2$  and the probability is only  $P_1$  and  $P_2$  of every result then the formula of expected value is

$$\Sigma_v = P_1 (X_1) + P_2 (X_2)$$

Suppose that tossing the coin between two players, this is decided that of first time tossing the coin comes head then the player will get ₹ 100 and if comes tail he will have to pay ₹ 60. According to Table 2, the probability distribution is respectively 0.6 and 0.4 then the expected value of this condition is as follows –

Table 2		
<i>Incident</i>	<i>Result</i>	<i>Probability</i>
Win	₹ 100	0.6
Loose	-₹ 60	0.4

The expected value or payment of player is ₹ 36 means.

$$\Sigma_v = 0.6 (\text{₹ } 100) + 0.4 (\text{₹ } 60) = 60 - 24 = \text{₹ } 36.$$

## 28.1 Individual Consumer's Behaviour Towards Risk

The traditional utility analysis is the behaviour of a consumer in between the risk free and the certain selection. **Newmann** and **Morgenstern** studied the behaviour of a man based on its risky selection of expected utility by gamble, lottery tickets. **Freidman** and **Sewage**, and later **Markowitz** amended the theory implementing in purchasing the insure for risk.

We study the risk preference of a man to understand the individual behaviour for risk.

### Self Assessment

#### Fill in the blanks:

1. Uncertainty is the ..... fact of human life.
2. The difference in Risk and ..... is necessary to know.
3. The uncertainty is the situation, where the possible .....

## 28.2 Risk Preference: Attitude Towards Risk

The attitude towards risk of a man depends on his selections and its expected profit to be received. Generally, this is expected that high risk-high gain. A personal decision shows the risk preference or the attitude of a person and the preferences are different in every individual. Some people like to take risk, some against to take risk and some neutral to take risk. The people, who take risk, expect more return profit, monetary income and utility.

To describe the attitude towards risk of a man, we can present the example of gamble. The players are paid while tossing coin in the gamble. Suppose that a person has ₹ 10,000 and he bet for ₹ 10,000. If he wins the game then he will receive the ₹ 10,000. In reverse condition the amount will be lost by him. This way, both results are expected. Means every result has 50% possibility. In this game the expected value  $-E_v$  or payoff is –

$$E_v = 0.5 (\text{₹ } 10,000) + 0.5 (-\text{₹ } 10,000) = \text{₹ } 5,000 - \text{₹ } 5,000 = 0. \text{ This is a fair game of honesty in which the result of expected value is 0.}$$

The attitude towards risk of a man are of three kinds which depend on this factor that the man accept the fair game or not.

**Notes**

1. **Risk Neutral:** Such kinds of man play if the odds (possibility) are in his favour. If the odds are not in favour then he will not take part and plays the neutral fair game.
2. **Risk loving:** Such kind of man excited to play even if the odds are not in his favour. He will play the game only for ₹ 1,000 possible winning amount losing ₹ 10,000.
3. **Risk Averse:** Such kinds of man will not take part if the odds are not in his favour. But if odds are in favour in full support then he will be ready to play. A risk average person is not ready to play even fair game.

**Risk Preference and Expected Utility**

Generally, men play in casino to earn more money or betting in race which gives them satisfaction. Economists measure the satisfaction by utility. They describe all the three types of men relating to their risk preference.

**Self Assessment**

**Multiple choice questions:**

4. In all financial transactions, there is ..... .  
 (a) element of risk    (b) element of expenditure    (c) element of profit    (d) element of loss
5. Attitude toward, risk of a man is of ..... .  
 (a) two kinds            (b) three kinds            (c) four kinds            (d) none of these
6. The possibility of incident is the number of occurrences (frequency)-  
 (a) ration                (b) percentage            (c) frequency            (d) none of these
7. A risk loving man is ready to play earn odds are not in favor-  
 (a) excited                (b) depend                (c) desperate            (d) none of these

**Assumptions**

**The analysis assumes that –**

1. The satisfaction of human is linked with money.
2. Utility is a measure of his satisfaction.
3. Man has a certain amount of assets.
4. He plays the tossing coin game.
5. He knows the all probabilities.
6. His selection is definite.
7. He maximizes the expected utility means he opt the payment or expected utility is maximize.

Having these assumptions, think about a gamble, in which a player is paid after tossing the coin. Suppose that a man has ₹ 10,000 and bet on ₹ 5,000. Tossing the coin if head comes, he will earn ₹ 5,000 otherwise coming tail he will lose ₹ 5,000. If he does not bet definitely he will remain at ₹ 10,000. This situation is called certain prospect. But if he bets either on the possibility of winning 0.5 will get ₹ 15,000 (₹ 10,000 + ₹ 5,000) or the possibility of losing 0.5 will get ₹ 5,000 (₹ 10,000 - ₹ 5,000). This situation is called certain prospect. It means that the probability of every result has 50 per cent. In this game the expected value or payoff is –

$$E_p = 0.5 (\text{₹ } 5,000) + 0.5 (\text{₹ } 15,000) = \text{₹ } 25,00 + \text{₹ } 75,00 = \text{₹ } 10,000$$

Now this analysis is linked to utility for every rupee, the expected value is implemented on three types of risk attitude.

Notes



Task Explain your ideas about risk preference.

### Risk Neutral

The neutral attitude has been shown in Fig. 28.1 about the attitude towards risk in which the money is on horizontal axis in rupees and every expected value linked to utility is on the vertical axis. ₹ 10,000 is with certain odds linked to expected utility 16. For indefinite odds the expected utility is –

$$Eu = 0.5 (8) + 0.5 (24) = 4 + 12 = 16.$$

We find the game in risk neutral, the linked utility with certain odds, is equal to the utility linked with its uncertainty odds means  $16 = 16$ . Here both the expected monetary values are equal which described as an example above. Curve TU shows the complete utility which is certainly received by a man from his income. This is a inclined straight rule towards upside in the figure which shows the constant marginal utility of income, as in curve TU, BA and BC are placed at equal distance from centre of dots.

Fig. 28.1

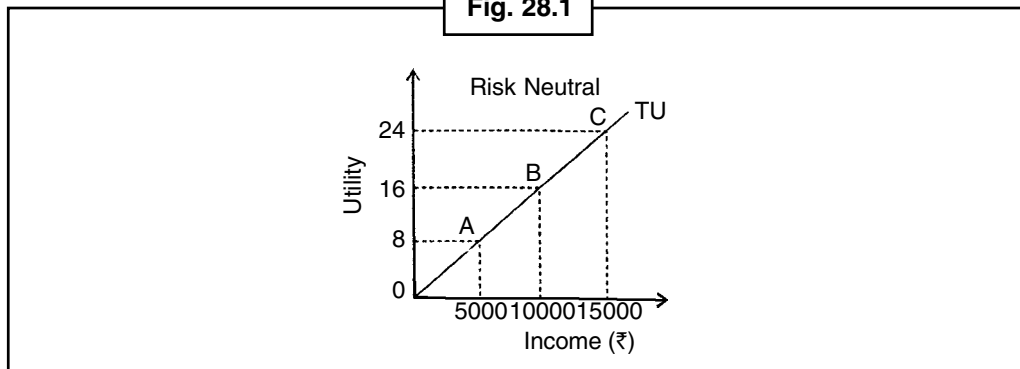

### Risk Loving

Figure 28.2 shows the risk loving man which TU curve is being inclined upwards which shows the maximum utility of the increasing income ₹ 10,000 the certain odds is linked with expected utility 10 and the uncertain odds linked with the expected utility is–

$$Eu \ 0.5 (4) + 0.5 (20) = 2 + 10 = 12$$

When 4 is the result of utility level of ₹ 5,000 and 20 is of ₹ 15,000.

Notes

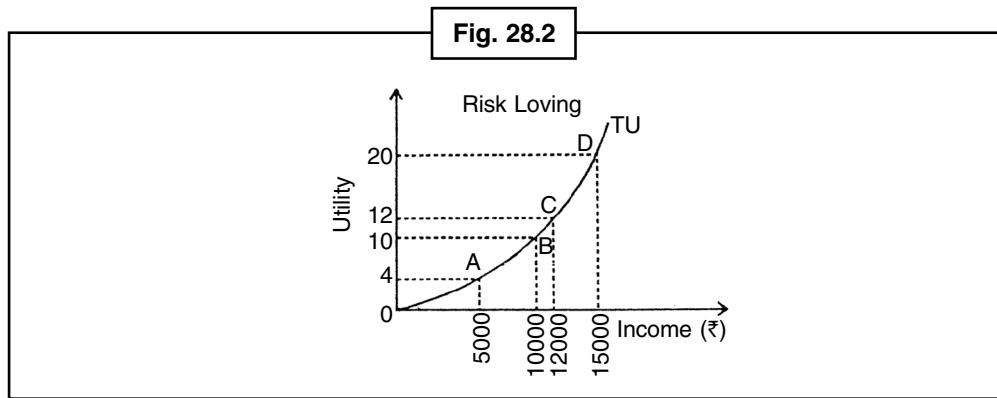

Uncertain odds (12) the expected utility is more than the certain odds (10) the expected utility, means  $12 > 10$ . So this man will prefer (the expected utility 12) with uncertain odds like gamble more than (the expected utility 10) with certain odds. This is the gamble of the TU curve win two utility level game ₹ 12,000. So the risk loving man will play for his certain odds (₹ 10,000) and above ₹ 2,000 (₹ 12,000 - ₹ 10,000).

**Risk Averse**

The situation of a risk curve man is shown in Fig. 28.3 in which the TU curve is inclined to show the maximum utility from the reducing income. Like ₹ 15,000 is more than 10,000 then 5,000 the maximum utilities is 10 to 8 (= 18 - 10) and 8 to 4 (= 22 - 18). So the ₹ 10,000 is the certain odd linked with the utility is 18.

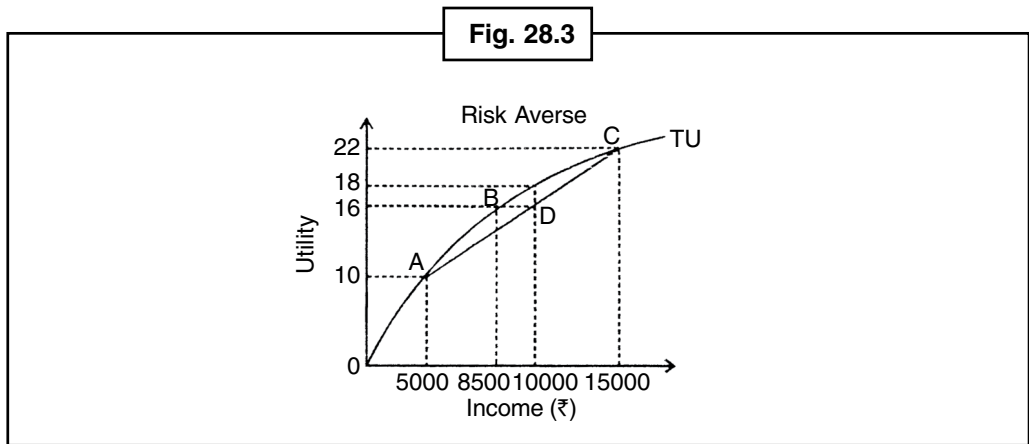

For uncertain odds the expected utility is 16 when the result ₹ 5,000 is the utility level 10 and ₹ 15,000 is 22 is shown falling way –

$$Eu = 0.5 (10) + 0.5 (22) = 5 + 11 = 16$$

In this example, the expected utility of uncertain odds is 16 which is less than the certain odds utility (18) means,  $16 < 18$ . The risk averse man will prefer more for low utility uncertain odds than the higher utility with certain odds. This way he will avoid the condition and he will ready to pay ₹ 1,500 which is the difference set by a man for the certain income ₹ 8,500 and ₹ 10,000. This difference is called **Risk Premium**.

To decide the size of risk, we increase our example and describe this in Fig. 28.3. Point A and C to be net by a line of the TU curve, which is linked with the income utility level of the ₹ 15,000 with 22 utility and ₹ 5,000, with 10 utility. In figure we can see that the expected utility with certainty on the point B is ₹ 8,500 at TU curve. This amount is equal to amount of certainty in the game by the man. Averse but the preference to the utility 16 will ₹ 10,000 certain income as is explained by the drawing a horizontal line to the point B to D on the line AC. Similarly risk premium BD part in the figure is ₹ 1,500. The difference of income is on the equal expected utility 16 on the ₹ 10,000 certain and 8,500 uncertain.

## Measures to Reduce Risk

Apart from risk-lovable people, people do not want to take risk always when they face the risk. There are various solutions which reduce the risk among people. The details are –

### 1. Insurance

People take insurance policy against various risks like death, injury, theft etc. and transfer their risk. The insurance companies take the premium and on the basis of that premium they cover the risk and compensate. The lesser risk taking people buy policies by paying premium to cover their risks.

Think about a man who takes decision to buy policy for loss of house if fire. If the cost of house is ₹ 20,00,000 and the probability to catch fire in a year is 400 (1/400). He has two options – **First**, if he does not take policy and there is no fire then the cost of house remains ₹ 20,00,000 and in case of fire, it is zero. **Second**, if he buys policy and pays ₹ 5,000 to insurance company as premium, then the cost of his house after 8 years, if there is not fire,  $20,00,000 - 5,000 = ₹ 19,95,000$ . If the house destructs from fire then the insurance company will pay him ₹ 20,00,000 as cost of his house.

### 2. Diversification

Risk can be lowered by diversification. When a firm instead of concentrating only on one type business and starts running another type of business, then the risk gets lowered. The insurance companies are profit maximization firms. So by just doing a type of insurance, they sell policy for home, health, car, life etc. By diversification in various insurances, they expand their risks. Thus, an investment can lower his risk by diversification in market. By adding various stocks to his portfolio, he can safe from expected loss stocks.

### 3. Future Market

The people try to reduce their risks by future market. Generally, the future market is present in agricultural products and stock etc. Suppose that farmer grows rice and he does not know that the price of rice would increase or decrease later. He is indefinite about his future and income. So he needs the policy for lower market price. To cover the risk of his future, he signs an agreement with a rice stockist to come with a unique quantity of rice on a special date. If the price of an expected bag of rice is ₹ 300 and the expected high is ₹ 400 then the fair odds delivery price would be ₹ 350. To give the rice on this price, the farmers reduces his risk without taking any risk in future.

## Self Assessment

State whether the following statements are True/False:

8. Generally it is expected that the big risk covers big profit.
9. The player pays by tossing the coin in gambling.
10. A risk-loving man does not participate in game if he finds there is no possibility in his favour.

## Notes

**4. Forward Market**

In a forward market, on future date, there is an agreement to give product which is agreed on today. The forward market is for many products like sugar, wheat, tea, gold, silver, foreign currency etc.

Think about a forward market of gold. Its current price (means today's) is ₹ 5,000 per 10 gram. This is called **Spot Price** for urgent delivery. People expect the similar ₹ 5,500 price on next year, which is its **future spot price**. So, gold a person can hedging with a trader against this risk. Suppose that he agrees to sell a kilo gold to a trader on ₹ 5,300 per 10 gm on future price. Therefore, seller reduces his future price to sale at 5,300. So ₹ 200 (₹ 5,500 - 5,300) is like a premium which paid for come out risk of future price. If expected future price is ₹ 5,500 then hedging risk gets profit of ₹ 200 (₹ 5,500 - ₹ 5,300) per 10 gm which is his risk premium.

**5. Complete Information**

Due to incomplete information people get risk and instability. He cannot take decision for maximizing. If they do not get complete information, which he wants to sell or buy. In order to minimize the risk of selling or buying full information is necessary. It can be got by different advertisements. Economists called information is a object which can be bought or sold. It has price of information and price of complete information is expected as price of a alternative. It is the difference when information receives completely an expected price when information is incomplete. Take a firm which expends on advertisement and research by which people got information complete its object. So it has probability to increase in selling. Suppose expected profit is ₹ 25,00,000 with complete information but 13,00,000 is the expected price with incomplete. Difference between expected profit with complete information and incomplete information is ₹ 25,00,000 - 13,00,000 = ₹ 20000 which is price of complete information. So, firms earn ₹ 12,00,000 additional profit which is the complete information.

**28.3 Gambling**

Each person has a simple tendency to earn money without much labour. So, he takes risk and plays gambling in Ramp, Casino etc. We discuss below about coin and its individual behaviour –

Let us discuss about gambling when a coin jumps and a gambler has paid for it. If head has come in first toss then gambler gets ₹ 100/- but he would paid ₹ 100/- if tail is come. Two equal probability is got. Its mean that each has 50% probability. The expected value for this gamble is the sum of the outcomes weighted by their probability.

$$\begin{aligned}\text{So expected price} &= 0.50 (\text{₹ } 100) + 0.50 (- \text{₹ } 100) \\ &= \text{₹ } 50 - \text{₹ } 50 = 0\end{aligned}$$

It shows probability to win that ₹ 100 is 50% and 50% probability in gambling of ₹ 100. It has said fair odds. A fair odd is that whose expected price is 200 or average economic profit is 200. It is also called zero sum game. If 20% probability is to win ₹ 100 and 80% probability is to loss ₹ 100 then it is called unfair gamble. In spite of it, if 20% probability is to loss ₹ 100 and 80% is to coin ₹ 100 then it is called formally gamble.

Now we compare two coin tossing games, in first game, 50% probability to win or loss ₹ 100 and in the game 50% is same probability to win ₹ 200 both are zero Sum gamble but it is more risk in other games . If game has stopped after first toss. The gamble gets ₹ 100 is respect of win loss ₹ 50.

## Individual Attitudes to Gambling

Notes

There are three types of behaviour of a person about gambling which depend on accept or reject of favors gambling.

### Risk Neutral

A risk neutral person is gambler of playing more and more and whose purpose is to maximize his money by wining gambling. He only thinks about expected value of bet. It is so that when a coin keeps jumping more then average return is its expected value.

It is shown in Fig. 28.4 in which points A and B are equal expected value and they are attracted equally for gambling who play more and more. Suppose gambler has ₹ 100 to bet and it has 50% probability to come head and 50% to tail then point A is expected price of gambling.

$$\begin{aligned} E_v &= 0.50 (\text{₹ } 100) + 0.50 (\text{₹ } 100) \\ &= 50 + 50 = \text{₹ } 100 \end{aligned}$$

Expected value of gambling at point B

$$\begin{aligned} E_v &= 0.50 (\text{₹ } 80) + 0.50 (\text{₹ } 120) \\ 40 + 60 &= \text{₹ } 100 \end{aligned}$$

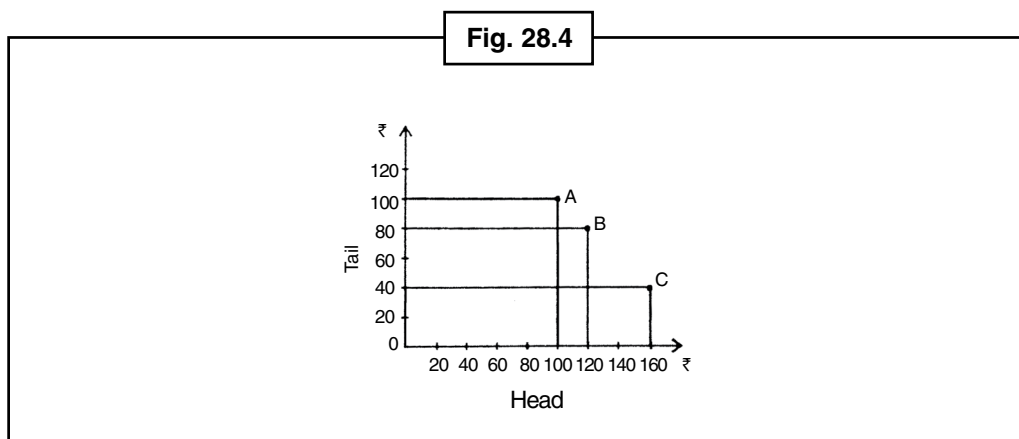

Therefore, on point C and on other points if he continues to jump the coin then the average will ₹ 100.

A risk neutral gambler is neutral on fair odds. It is because he can differentiate in risk of gambling and in long run, he will win expected price. He will play on favourable odds and will not play on unfavourable odds.

### Risk Loving

A risk loving person is ready to play gambling even if probabilities are not in his favour. It will like high risk alternatives of gambling of equal expected value. He will take risk even he loses, even when it is not in his favour. It is shown in Fig. 28.5. Where concave neutral curve of gamblers are  $I_1, I_2, I_3$  which show different alternatives of choices. For TH line (Budget line) it is its money.



Notes

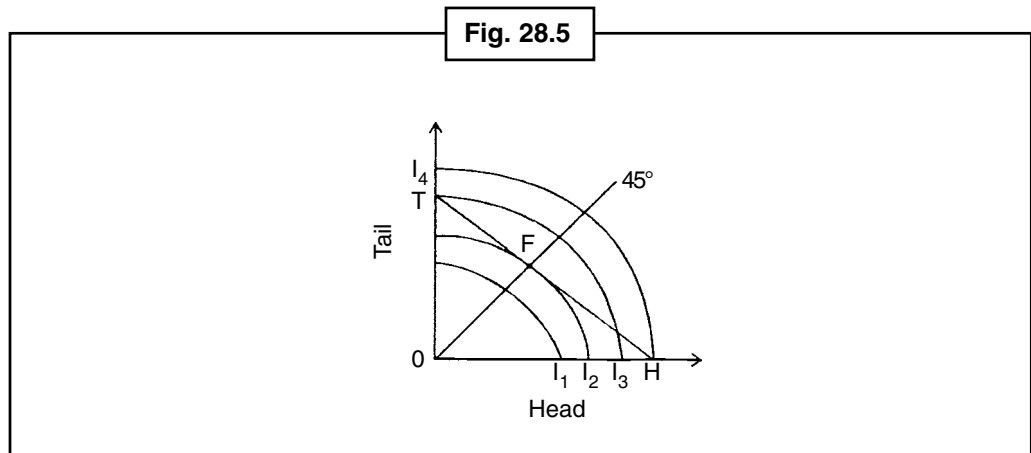

F is a point of fair odds on which his budget line TH touches on neutral  $I_2$ . Gambler will not take chance on fair odds if he is risk loving. But he will always choose tough solutions. If he takes bet on tail and after jump coin it comes head then that point will H and he will lose all money. In other side, if it comes tail then it will on point P and will on money of bet.

**Risk Averse**

A risk averse is that person who will not take risk even in fair odds. But he will gamble if probability is in his favour. Suppose that he come with ₹ 100/- and he has 3 to 1 probability to toss the coin, then will lose ₹ 10/- if it comes tail and if it comes head he will win ₹ 30.

See Fig. 28.6 where head on horizontal axis and tail on vertical axis. If he on fair odds (1 by for 1), give chance to jump coin then he will not take chance and will remain on point A. He has ₹ 100/- and it will be secured. It is neutral curve I of A is decline on (1) which it cross Budget times.

Suppose that he is said to take risk on favourable odds 1. To take bet of 10/-, he come on point B which he likes point A of his budget point. It is better situation for him because he profits ₹ 30/-. His money increases from 100/- to 130/-.

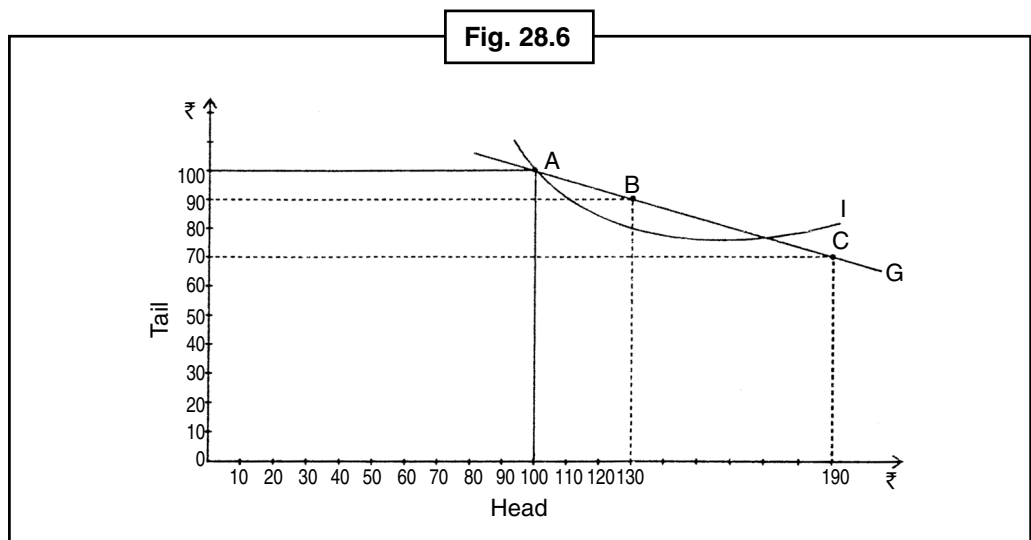

Now, suppose that according to casino rule, get bet of ₹ 30 or not any. In this situation the bet of ₹ 30/- points A goes to C which is not favourable for him because it is situated below its neutral curve. He will not take risk of ₹ 30 for profit of ₹ 90 and get refused to take set. Therefore, risk averse persons, even probability is in their favours, will take gambling.

## 28.4 Summary

- Behaviour of a man to risk depends on his selection and expected profit received by them. Generally, it is expected that with great risk there will more profit. Any individual decision shows their behaviour and risk taken by them and risk ability are different in each person. Some people like to take risk. Some oppose to take risk and some keep neutral to risk. Those who take risks expect to get more return, profit, income and prices.

## 28.5 Keywords

- **Probability:** Possibility
- **Expected Value:** Expected value in money

## 28.6 Review Questions

1. What should the behaviour of a consumer for risk?
2. What is Risk Preference? Explain it.
3. Express your opinion about Gambling.

## Answers: Self Assessment

- |                |                |             |         |
|----------------|----------------|-------------|---------|
| 1. Fundamental | 2. Uncertainty | 3. Measured | 4. (a)  |
| 5. (b)         | 6. (a)         | 7. (a)      | 8. True |
| 9. True        | 10. False.     |             |         |

## 28.7 Further Readings



Books

1. **Microeconomics: An advanced treaties** – S.P.S Chauhan, PHI Learning.
2. **Microeconomics: Behaviour, Institutions and Evaluation** – Sampoole Bowels, Oxford University Press, 2004.
3. **Microeconomics: Principals, Applications and tools** – Sanjay Basotiya, DND Publications, 2010.

## Unit-29: Insurance Choice and Risk

### CONTENTS

Objectives

Introduction

29.1 Insurance

29.2 Choice between Insurance and Gambling: Friedman-Savage Hypothesis

29.3 Asset Portfolio Selection

29.4 Summary

29.5 Keywords

29.6 Review Questions

29.7 Further Readings

### Objectives

After studying this unit, students will be able to:

- Know about insurance.
- Select between insurance and gambling.
- Know asset portfolio selection.

### Introduction

An insurance company takes risk of the death of his customer that if he dies then it would pay a big amount to his family. When an insurance company sells insurance policies then it covers more than hundreds of families.

### 29.1 Insurance

There are two characteristics to decrease risk—**first**, in the view of that person who buys insurance policy and **second**, in the view of insurance companies who sell insurance policy.

#### **1. From the Viewpoint of Buyer of Insurance**

Insurance is opposite of gambling. It lowers the risk. When a person buys policy for himself or to protect his dependents or to protect his property from accident, fire, theft etc. unknown incidents, then he lowers the risk. There is the market of policy because people are risk averse.

Notes

Just think about a person who has a bike of ₹ 50,000. He buys a policy of ₹ 5,000 for protecting his bike from theft, accident etc. He assumes that the probability of theft is 0.1 and expected loss is ₹ 5,000 ( $= 0.10 \times ₹ 50,000$ ). Since the cost of policy ₹ 5,000 is equal to expected loss ₹ 5,000, so he will buy policy to get rid from risk that if the bike has stolen he can get the full amount of bike.

The risk averse people has two options—(1) if he does not take policy then the probability of fault is 0.1 means ₹ 5,000 (2) If he takes policy then there is no scope of loss of ₹ 50,000. He pays ₹ 5,000 as policy premium and gets profit of ₹ 45,000 as 0.9 probability. A risk averse by doing this kind of action, got ends the risk. But an insurance company wants to get profit. So it does not imply the fair laws as stated above. It takes more premiums, let's assume ₹ 5,500. ₹ 500 is its cost and it is actually its profit or income.

Like all persons, a risk averse person has also marginal utility of capital. When he buys a insurance policy after the probability of 0.1, he thinks the risk low amount as decrease of his wealth.

This is shown in Fig. 29.1 where capital which is the current value of bike shown on vertical axis. If bike has stolen then point A shows ill-less result with capital  $W_1$  and utility  $U_1$ . If bike has not stolen then point B shows ill-less result with capital  $W_2$  and utility  $U_2$ . When he buys insurance and insurance company takes a premium (means ₹ 5,000) then he will be on point C with capital  $OW_3$  and utility  $OU_3$ . As a result, his capital decreases form  $OW_2$  to  $OW_3$ . But when the insurance company takes extra premium (₹ 500) to cover their risk then this opposite policy is as point D, by which his capital decreases by  $OW_4$  and utility by  $OU_4$ . This represents the decrease marginal utility of capital when risk averse person buys an opposite insurance policy.

Fig. 29.1

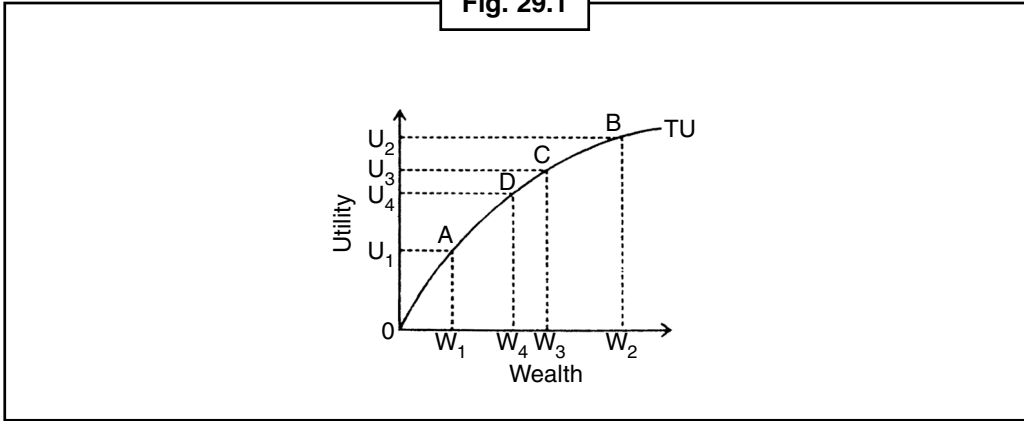

2. From the Viewpoint of Insurance Company

The work of insurance company is to fill the loss due to any accident. It decreases the loss by taking a small amount as premium amount and that for accident, which policy covers; it delivers to pay a big amount to his customer. Since more people are risk averse, they even ready to pay premium in odds situation. Thus, the insurance companies are also risk averse. They also want to get profit like firms. To get rid from risk and to get profit, they use risk pooling and risk spreading concept.

Self Assessment

Fill in the blanks:

1. In front of risk averse .....
2. There is the market of policy because people are ..... averse.
3. An insurance company takes the risk of his customer's death with .....

Notes

### Risk Pooling and Risk Spreading

An insurance company takes the risk of his customer's death with little premium and if he dies, it will pay a big amount to his family. It can do very simply by collecting the risks of his customer. When an insurance policy sells the policy then it is not insured a single person but more than thousands people. It knows that the entire insured person will not die at all except atom war or epidemic. Some persons can die soon, some in the period of insurance and some will not die after policy matures. So they know geometrically that the premiums, which they collect from his customers, are more than the payment given to their customers. In other words, as much as it insured, the ratio of people would low who actually died annually. It is called **Law of Large Numbers**. It means as much as the insured person, for insurance companies, the average result will more forecasted.

Thus, the insurance policy can assume the risk and for profit, it can calculate on the premium amount collection from customer. Risk pooling, in a large amount of people, can possible only by risk spreading. It does not only mean that the quantity of insured person should high. It also means that the risk should independent from the risk covers by all people. Suppose that in a house, an insurance company insured policy for 100 people. If a big fire comes, then all houses can burnt. The company will get a big loss. In this condition, the risk of fire is not independent. Now if the similar company insured different houses then the risk is independent. There is the possibility to burn a single house rather than 100 at a time because a fire at one home is independent from another home. On the basis of this independent risk, various insurance companies do not cover war, flood, and earthquake like situations because if it happens, the risk is very wide.

Another method is diversification by which insurance companies widen their risk. They do various types of insurance like life insurance, house insurance, car insurance, medical insurance etc. to cover this.



Notes Insurance is opposite of gambling. It lowers the risk.

### Risk Sharing

Risk sharing is another form by which the insurance companies use to cut their cost of risk. The risk sharing happens when a person insured with a huge amount and if there is an accident, then the claim would waste to a company. This situation is related to a specific skilled person who insure a part of his body only. For example, to insure her voice by Lata Mangeshkar or Madonna, an artist from a bad incident which can stop him to act, etc. Since one person is insured for a big money, the premium is also huge. If nothing happens to that person, then company will get a huge profit and if anything happens badly then company will get a big loss.

In this situation, the insurance company opts risk sharing which is also called re-insurance. When company insures a person's skill, then by dividing this into sub policies, shares the risk from other companies. Every company gets a part of premium and the claim is also divided equally if the accident happens. The big example of risk sharing is the **Lloyd's Insurance Market**, London. Thousands of syndicates and insurance companies are its associate and every syndicate is further divided into 20 associates. Thus, by the risk sharing, a big money is divided and risk gets lower. By dividing the premiums in syndicates and its associated, if the risk happens, the payment is very low.

### Problems of Insurance

There are two main problems which insurance companies face. These are moral hazard and adverse selection which described as follows –

## 1. Moral Hazard

### Notes

This situation exists when a person, who is insured for illness, fire or car accident, behaves as the chances of that incident become higher. In this situation, the loss is shifted from person to insurance company and bears the big payment. Moral hazard happens when a person is speeding with his car or does not lock from the theft and it increases for the accident or theft. Thus, home owner or firm does not put fire system after fire insurance which increases the risk of fire. For health, an insured person gets chain smoker and gets higher of his risk of illness. As these types of situation, the behaviour of policy taker does change. He takes more risk than cover a policy.

The insurance policy does not give premium in favourable or fair odds due to moral hazard. It includes some unique behaviour to protect or lower the moral hazard. For example, an insurance company can sell policy to a firm or a home owner if the fire system is used; a person gets life insurance if he does the annual checkups; and the premium can increase for multiple accident drivers. Thus the insurance companies can decrease the number of payments by lowers the possibilities of fire, illness or accident. They can present various agreements to various customers. High premium is taken from high risk people and they get full protection, while low premiums are taken from lower risk people and they will get only partial protection.

Think about a people whose cost of house is  $W$ . If it catches fire then his money only  $W_2 = W - d$ , where  $d$  is wastage of his house. If that person gives  $\alpha_1$  premium and insured his house from fire then he will get  $\alpha_2$  payment if house catches fire. If no fire then his money will  $W_1 = W - \alpha_1$  which is insurance premium which he pays. If it catches fire then his money will  $W_2 = W - d + \alpha_2$ .

An insurance company due to risk averse, to decrease the moral hazard, presents his customer to some less favorable odds. This is shown in Fig. 29.2. Point P represents the cost of his house without any insurance. In the situation of fire, his money will decrease till OF. It assumes that the possibility of situation of fire from situation of fire is multiple of three times means 3:1. This indicates by the sloping of his budget line  $B_1$  which gives possibility of 1/3 (3 to 1). Now assume that the home owner gets insurance policy. To assume that fire happens from possibility 1 to 3, he selects point E on which his budget line  $B_1$  touches indifference curve  $I_1$ . Point E is risk free point for home owner which is with 45 degree line because  $\alpha_1 = NN_1$ . After paying the policy premium, his money is  $W_1 = W - \alpha_1$  or  $ON_1 = OF_1$ . So he does not think about fire and here the possibility of fire is maximum. Please note the 45 degree line has  $W_2 = W$  or  $W - d + \alpha_2 = W - \alpha_1$ , so the payment of insurance company covers only the losses of home if fire catches. Thus the insurance policy will never present him to possibility 3 to 1. This condition is shown in Fig. 29.2. The equilibrium point of home owner is R on which his budget line  $B_2$  touches his indifference curve  $I_2$ . On this R point, he pays  $NN_1$  premium but if catches fire, he will get payment lower insured money  $OF_2$  rather than old insurance money  $OF_1$ .

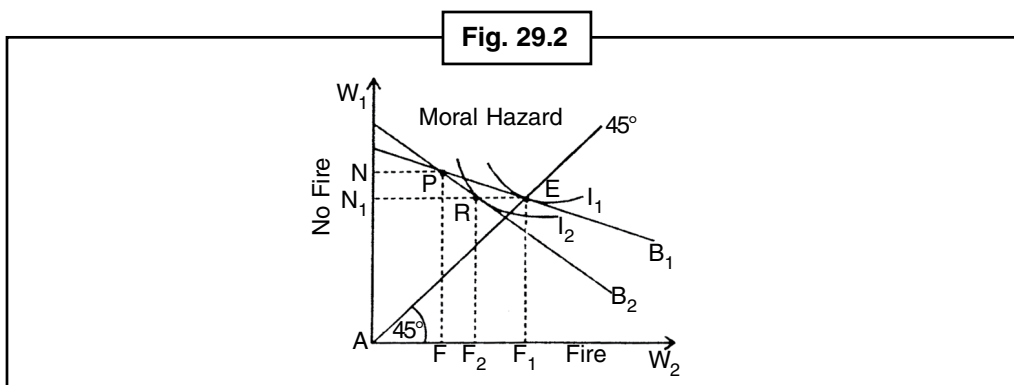



Notes

2. Adverse Selection

When insurance company knows less for the future incidents from the customer, then it creates adverse selection like personal illness insurance market. In this, the person knows more from the insurance policy, which however check his health while insured him. So the insurance company takes premium on the basis of national average. He will motivate more ill people to get insured than less fit people. On the other hand, fit people thinks that he is about to pay more against his low individual risk. Other hand, the ill people think that he is paying fewer premiums against his high risk. As a result, the higher risk people buy more insurance while lower risk people do not buy insurance. This is the problem of adverse selection which will bankrupt the insurance companies. This condition makes the high premium in insurance and thus the ill people stop getting insurance because they think that the individual payment is lower than policy premium.

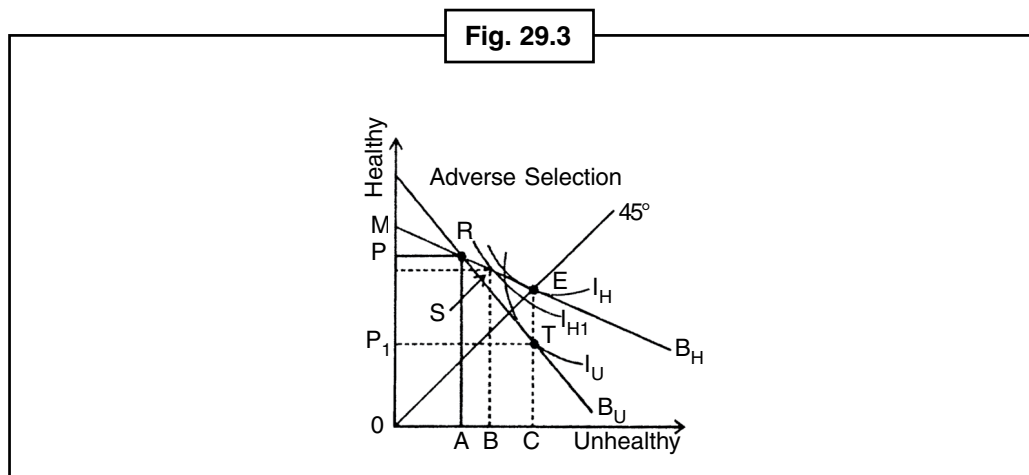
To getting rid from this adverse selection problem, the insurance company gets various premiums on the basis of various age limits and the nature of risk for industries. Thus the premium amount is more for high risk people than the low risk people. To solve the adverse selection, the insurance company fixes the rate for both the groups as shown in Fig. 29.3. Every person has OM money which is less in case of illness till OA. The illness possibility for fit people is 3 to 1 or 0.25 and ill people have 1 to 1 or 0.50. On this assumption, the budget line for fit people is  $B_H$  which touches their indifference curve  $I_H$  on point E and ill people has  $B_U$  line which touches their indifference curve  $I_U$  on point T. According to insurance company, the fit people should take insurance policy on T point with 3:1 possibility and ill people should take policy on point E with 1:1 possibility. But the insurance company cannot give two different policies because it cannot differentiate between these two groups. So it collects similar premium from both groups. As a result, ill people will get policy on point E with 3:1 possibility and when company needs to pay OC amount as payment and it will bankrupt the company. In this situation, company gives two options. One, for fit people on 3:1 possibility, it will take MP premium. They will be on  $I_{H1}$  curve on point S which touches his budget line  $B_H$ . If illness happens, the company will pay OB money to this group. Second, for ill people it will take  $MP_1$  premium on 1:1 possibility on point T and will pay OC money to this group. This result is only possible equilibrium. It can possible if insurance company can know about the fit and ill people by repetitive medical tests and past health history.



 Did u know? The work of an insurance company is to give decisiveness to any loss incident.

## 29.2 Choice between Insurance and Gambling: Friedman-Savage Hypothesis

Notes

Some people are risk averse and they spend their life to review their insurance protection and involve in gambling in casino. This is a paradox because it indicates that people can be risk averse and risk loving at a time. In fact, there is no paradox because the behaviour insurance which can be bought depends upon their nature and cost as well as the game of gambling.

If a person buys an insurance policy then he wants to get rid from risk. But when he buys a lottery ticket then he gets small occasion of big profit. Thus, he takes risk. Some persons take in both insurance and gambling and thus they take risk and protect too. Why? Answer has given by **Friedman-Savage Hypothesis**. It tells that for income the marginal utility comes down on a level. It increases between a level of income and any high level and again decreases for all income over that upper level. This is shown in Fig. 29.4 as total utility curve TU where utility is shown on horizontal axis and income is on vertical axis.

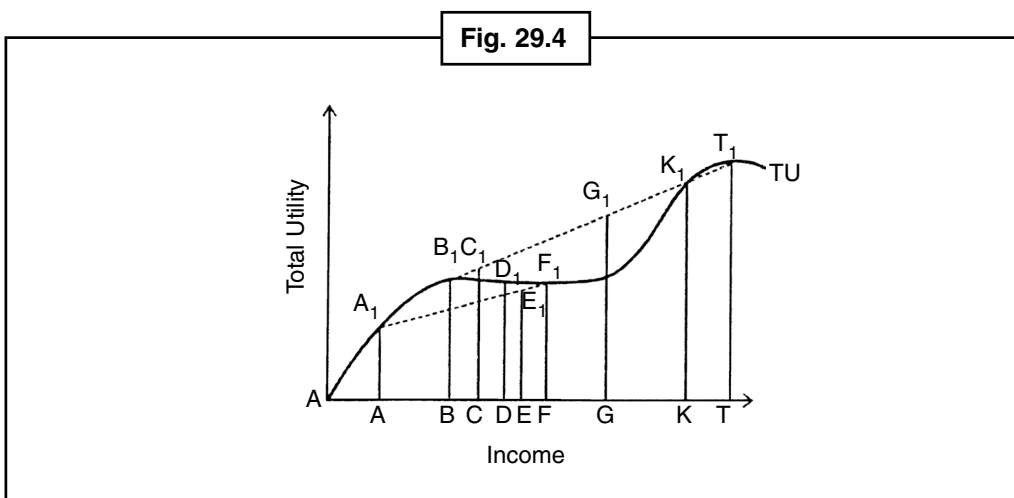

Suppose that a person buys insurance policy to protect his house from fire and he also buys a lottery ticket which gives a small occasion to him for a big deal. This paradox has shown by a total utility curve by Friedman and Savage. This type of a curve primarily goes upward in decreasing rate by which the marginal utility of money gets low and then it gets upward in increasing rate by which the marginal utility of money gets high. In Fig. 29.4, TU curve first goes downward to point  $F_1$  and later goes upward till point  $K_1$ . Suppose that the income of a person **without fire** with  $FF_1$  utility is  $OF$ . Now he buys policy to get rid of risk of fire. If fire catches the house then his income will decrease by  $OA$  with  $AA_1$  utility. By adding point  $A_1$  and  $F_1$ , we get utility points in these two unknown income condition. If the possibility of **non fire** is  $P$  then the expected income of this person is

$$Y = P (OF) + (1 - P) (OA)$$

Suppose that the expected income of person is  $(Y)$   $OE$  then its utility is  $EE_1$  on pointed line  $A_1F_1$ . Now suppose that the cost of insurance (insurance premium) is  $FD$ . Thus the income with insurance is  $OD$  ( $OF - FD$ ) which gives his more utility from  $EE_1$  to  $DD_1$  in case of no fire possibility expected income is  $OE$ . So that person pays  $FD$  premium to get fixed income  $OD$  in case of fire and to get rid of risk.

After taking insurance for fire protection, he decides to buy a lottery ticket with rest of his income  $OD$  whose price is  $DB$ . If he will not win then his income will fall by  $OB$  with  $BB_1$  utility. If he wins then his income will rise by  $OK$  with  $KK_1$  utility. Thus his expected income with possibility of not winning lottery  $P^1$  is—

$$Y_1 = P^1 (OB) + (1 - P^1) (OK)$$



**Notes**

Suppose that the expected income of person is  $(Y_1)$  OC then his utility is  $CC_1$  on pointed line  $B_1K_1$  which gives him more utility ( $CC_1$ ) while buying lottery ticket which is more than  $DD_1$  utility of not buying ticket. Thus, the person will buy lottery ticket with premium pay for fire protection of his house.

Now we suppose expected income OG from the upper part  $F_1K_1$  of TU curve when the marginal utility is rising for income. In this condition, the utility of lottery ticket is  $GG_1$  which is more than  $DD_1$  if he does not buy lottery ticket. So he will put his money in lottery ticket.

In the last stage when expected income of person is more than OK in  $K_1T_1$  region of TU curve, then the marginal utility gets low and hence he does not get involved in any favorable odds like lottery tickets.

**Self Assessment**

**Multiple choice questions:**

4. Insurance Company do ..... in risk.
 

(a) partnership	(b) stake	(c) buy	(d) none of these
-----------------	-----------	---------	-------------------
5. Every company gets ..... of premium.
 

(a) two part	(b) one part	(c) three part	(d) none of these
--------------	--------------	----------------	-------------------
6. The big example of risk sharing is the Lloyd's ..... London.
 

(a) stake	(b) market	(c) insurance market	(d) none of these
-----------	------------	----------------------	-------------------
7. High risk people get insurance ..... .
 

(a) more	(b) less	(c) lessen	(d) none of these
----------	----------	------------	-------------------

**29.3 Asset Portfolio Selection**

An investment does not only think about the security of his asset but he also thinks to get more expected income and lowers the risk too. This depends on the portfolio selection of asset which he has or he has selected. A portfolio is a group of many stocks like share, bond, security, treasury bill etc. It can be stock or can be business in market. These all assets are risk covered because the future result is unknown of these. In other words, the result of these cannot get same as calculated. The real result can differ from assumption. So the risk can say as loss or change. Thus the risk is related to variability or dispersion of expected returns.

For an investor, the return from his asset like profit margin, interest, bonus is **expected cash inflow**. The return can profit or loss in percentage in capital money. The current expected price of this return is expected profit of stock person.

**Mean Variance Analysis**

The rate of portfolio of an investor is the average of rate of gaining individual investment. Weight is percentage of total portfolio. The expected received rate for portfolio can be given like –

$$E_{R_i} = (\alpha)^2 \sum_{i=1}^n W_i R_i$$

Where

$W_i$  = percentage of portfolio in asset  $i$

$R_i$  = expected rate of return in asset  $i$

Table 1 shows the expected rate of 4 risk assets.

The expected rate of return for this portfolio of investment is 12 percented.

If the expected return rate has given, then a risk of investor can be measured by standard deviation or variance of expected return. This is change of expected rate of return ( $R_i$ ) on farm of expected rate ( $ER_i$ ) –

$$\text{Standard deviation } (\sigma) = \sqrt{\sum_{i=1}^n (R_i - E_{R_i})^2 P_i}$$

Where  $P_i$  is expected rate of return and the possibility of  $R_i$ . Variance is the class of standard deviation.

$$\text{Variance } (\sigma)^2 = \sum_{i=1}^n (R_i - E_{R_i})^2 P_i$$

Number of Assets (1)	$W_i$ (2)	$R_i$ (3)	$W_i \times R_i$ (4)
1	.10	.10	$(.10 \times .10) = .010$
2	.20	.11	$(.20 \times .11) = .022$
3	.30	.12	$(.30 \times .12) = .036$
4	.40	.13	$(.40 \times .13) = .052$
			$E_{R_i} = .120$

Risk asset portfolio standard deviation and variance table of receipts has been calculated based on the assumption of table 2 that (1) are identical possibility  $P_i = .02$  and (2) the expected rate of return  $R_i = .12$ .

The table shows that standard deviation of a risk covered portfolio is .2 and its variance is .0004 when expected rate of return is .12 and possibility is .20.

### Selection of an Efficient Portfolio – The Markowitz Portfolio Theory

The selection of an efficient portfolio means an investor should select a portfolio by which he can get maximum profit with low risk. The **Markowitz Portfolio** theory indicates that how an investor can take an optimum portfolio under risk. **Prof. Harry Markowitz** was the first economist who proposed original portfolio model in 1952. A portfolio of assets in its model to achieve the required rate and expected rate of return standard deviation of (or variance) required as a measurement of derivative risks. The standard deviation of a portfolio is not a calculative result of individual investment but it is a covariance between expected rates of return for all pairs of portfolio. Markowitz has shown the diversification of a portfolio to lessen the risk.

### Its Assumptions

The **Markowitz** model is based on following assumptions –

1. An investor is risk averse.

Possible Rates of Return	Expected Rate of Return	$R_i - E_{R_i}$	$(R_i - E_{R_i})^2$	$P_i (R_i - E_{R_i})^2 P_i$
.09	.12	-.03	.0009	.20 .000180
.11	.12	-.01	.0001	.20 .000020
.13	.12	.01	.0001	.20 .000020
.15	.12	.03	.0009	.20 .000180
				.000400

Standard Deviation =  $\sqrt{.00040} = .02$   
 Variance  $(\sigma)^2 = .0004$

**Notes**

2. He estimates the risk of portfolio by changing in expected rate of returns.
3. He thinks all investment are is expectedly declared with investment options.
4. He maximizes a time for expected utility.
5. The utility curve of an investor shows the decreased marginal utility of money.
6. The decision of an investor for portfolio is based on expected returns and risks.
7. The utility curve of investor is result of standard variation of returns and variances of expected returns.
8. In a given level of risk, an investor gives preference to higher returns rather than low.
9. He gives preference to lower risk than higher for getting a level of expected returns.

**Self Assessment**

State whether the following statements are True/False:

8. A portfolio is not a group of many stocks like share, bond, security, treasury bill etc.
9. The risk is related to variability or dispersion of expected returns.
10. Weight is the percentage of total portfolio.

**The Model**

On the given assumption, suppose that investment has many assets available on which he can invest. There may be two combination of assets in portfolio. Every combination has a level of risk and expected return. An investment chooses minimum risk or maximum risk portfolio. It depends as what he wants to expect from his investment and how much he wants the risk. So in given two combination of assets portfolio, investor selects the best portfolio. For selecting the best portfolio, investor has two decisions – **One**, determination of efficient set of portfolio, and **two**, to select best or optimum portfolio from this efficient set of portfolio.



*Task* Give your thought on gambling and insurance.

**The Efficient Set and Efficient Frontier**

The efficient set of portfolio of asset is good if it gives higher expected returns or minimum risk on this higher expected return. In other words, a portfolio is efficient if another portfolio gives similar risk and higher returns or higher returns on minimum risk. It is shown in Fig. 29.5 where a standard variation ( $\sigma$ ) of a portfolio of asset is shown on vertical axis which measures the risk and the expected returns of portfolio ( $E_R$ ) is in horizontal axis. Whichever is with point region ENMF, efficient portfolio and this region EF is called **Efficient Frontier**. A group of portfolio on which every risk level expected return is higher or the risk of expected return is lower is called **Efficient Set**. The group efficient portfolio is **Efficient Portfolio**. This is the only portfolio which a risk averse person will opt. Suppose that the level of risks  $r_2$ , there are two portfolios K and M. From these, M is an efficient portfolio because for the given level of risk  $r_2$ , the expected rate of return is  $r_2$  M is higher and it is on efficient region EF. Thus from N and K portfolios, N is efficient portfolio because its risk  $r_1$  is lower while  $r_2$  risk of portfolio K is higher. But the expected returns level of both are OR. So he would select N portfolio.

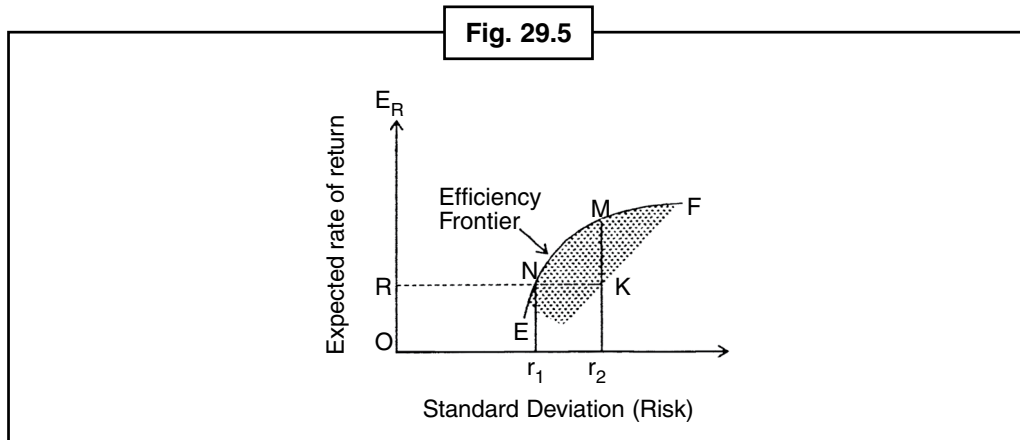

### The Optimal Portfolio

In efficient frontier, the investor will opt that portfolio in which risk return preference is higher utility from various possible portfolios. Because risk averse investor thinks expected returns “good” and risk ( $\sigma$ ) as “bad”. His preference indicates by indifference curve from various portfolios. To determine the efficient frontier, these indifference curves determine which efficient portfolio he selects. That is optimal or best portfolio.

Figure 29.6 shows three indifference curves  $I_1$ ,  $I_2$  and  $I_3$ . The upward slope from left to right indicates risk covered exchange. Curve  $I_2$  shows more preference than curve  $I_1$  and curve  $I_3$  shows more than curve  $I_2$ . EF is efficient frontier. P is optimal portfolio point where curve EF touches curve  $I_2$ . Point A is also on  $I_2$  curve. But this is not the point of **optimal portfolio** because it is outside the efficient frontier. Again point B on  $I_1$  curve is not optimal portfolio because this gives preference of minimum risk to investor. Thus P is optimal portfolio because it is on the tangent point of maximum risk preference  $I_2$  curve and efficient frontier EF.

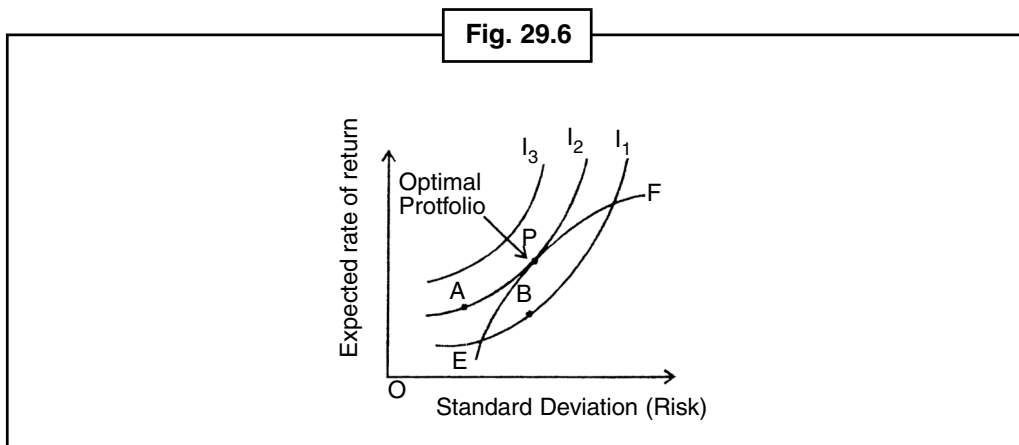

### Risk Reduction through Portfolio Diversification

An investor can reduce his risk of investment in stock market by risk diversification. The meaning of diversification is to expand his investment into two or more than two assets or shares. This is like “not

**Notes**

all eggs in a bucket". To reduce the risk, investor makes diversification as a condition on his portfolio. To understand the portfolio diversification, an investor has ₹ 100 to invest in two risk asset shares BP (Bharat Petroleum) and SAIL (Steel Authority of India Limited). The price of unit per share is 1. The profit and loss is 50 percent from both the shares.

Now suppose that he invests all ₹ 100 to buy share of BP. This gives him ₹ 10 profit and ₹ 2 in crisis. Rise and fall of 50-50 percent occasion, the expected average return of him is -

$$E_R = .5 (\text{₹ } 10) + .4 (\text{₹ } 2) = \text{₹ } 6$$

The variance

$$(\sigma)^2 = .5 (10 - 6)^2 + .5 (2 - 6)^2 = \text{₹ } 16$$

Suppose that he invests ₹ 100 in share of SAIL. He expects ₹ 2 in rise and ₹ 10 in crisis. Rise and fall of 50-50 percent occasion, the expected average return of him is -

$$E_R = .5 (\text{₹ } 2) + .5 (\text{₹ } 10) = \text{₹ } 6$$

The variance

$$(\sigma^2) = .5 (2 - 6)^2 + .5 (10 - 6)^2 = \text{₹ } 16$$

Thus, the expected return from both the shares is ₹ 6 per share and variance is ₹ 16 per share. It shows that the risk and expected return is similar by investing two independent shares. But there is a main difference between these two investments. The expected return of BP share is high in rise and low in crisis. But with shares of SAIL, it is opposite.

This combination of share is not useful for investors because the risk and returns for both the shares are equal. This is so because the returns are not independent. But there is a negative correlation in them. When one gets higher then second gets lower and vice versa.

An investor can reduce the risk by taking some shares without change in expected returns. It is called **diversification through risk pooling**. Suppose that an investor invests ₹ 50 in shares of BP and the same amount in share of SAIL and thus he diversifies his investment. Now he will get ₹ 5 from BP share and ₹ 1 from SAIL share in rising. The average return is ₹ 6. He will get ₹ 1 from BP share and ₹ 5 from SAIL share in crisis which again gives him the expected return of ₹ 6. Thus however rising or crisis, the expected return is still ₹ 6. By getting ₹ 2 or ₹ 10, he is now relaxed with getting returns as ₹ 6 chances are 25 percent and ₹ 6 Expected average 50 percent chances of recovery.

Risk diversification works only when the returns of share is independent from each other and correlated positively means two assets go into one direction.

### Measuring Market Risk and Specific Risk

A portfolio owner has two types of risk – Market Risk and Specific Risk. Market risk is related to gaining of a unique share when all stock market are in motion from upward and downward. The specific risk is related to getting the shares from many companies which is risk pooling and diversified, while market cannot risk diversified because the returns of shares in share market comes up and down simultaneously.

Economists use a coefficient Beta to measure that quantity whose work is related to motion to get a unique share. If a share moves on the similar direction where there is a market index, then its Beta will be 1. One high Beta share (Beta >1) means it moves in the similar direction where market is. But it is good when market is rising but it is bad when market is in crisis. Between 1 and 0 share, Beta means share works in the similar direction as market but in very lazy condition. A negative Beta share moves in opposite direction from nature of market.

Most of the shares move in the market direction and its **Beta** one (1) nearer **Beta**. But the negative Beta shares give preferences by investors because it decreases the risk of portfolio. Low Beta and negative Beta share also collect the risk of portfolio. But the high **Beta** share should avoid because it moves into market direction, the returns of its is more and it cannot be used to collect portfolio risk.

**Conclusion** – The characteristics of risks of share and its returns cannot divide from the nature of

market in a portfolio. This is the reason to use **Beta** by economists. If Beta of a share is lower than 1 then it will decrease the risk of risk portfolio even these **Beta** share are individually risky. But if it collects with other shares then portfolio will lessen the risks. So it should give preference from **Beta** shares by risk averse investor.

Thus, in stock market equilibrium, low **Beta** shares should be available in low return and high value. On the other hand, high **Beta** share increases the risk of portfolio and can buy when it has high average return rate for lower price and to compensate of high risk.

## 29.4 Summary

- The work of insurance company is to fill the loss due to any accident. It decreases the loss by taking a small amount as premium amount and that for accident, which policy covers; it delivers to pay a big amount to his customer. Since more people are risk averse, they even ready to pay premium in odds situation. Thus, the insurance companies are also risk averse. They also want to get profit like firms. To get rid from risk and to get profit, they use risk pooling and risk spreading concept.

## 29.5 Keywords

- **Return:** Return
- **Portfolio:** Bag of keeping paper
- **Distribution:** Distribute

## 29.6 Review Questions

1. What do you mean by insurance? Explain it.
2. Write comments on gambling.
3. Explain the Asset Portfolio Selection.

## **Answers: Self Assessment**

- |                |          |            |          |
|----------------|----------|------------|----------|
| 1. Two Options | 2. Risk  | 3. Premium | 4. (a)   |
| 5. (b)         | 6. (c)   | 7. (a)     | 8. False |
| 9. True        | 10. True |            |          |

## 29.7 Further Readings



Books

1. **Microeconomics**—Robert S. Predik, Daniel L. Rubenfield and Prem L. Mehta, Pearson Education, 2009, PBK, 7th Edition.
2. **Microeconomics**—David Basenco and Ronald Brutigame, Wiley India, 2011, PBK, 4th Edition.
3. **Microeconomics**—Shipra Mukhopadhyay, Annie Books, 2011.

## Unit-30: Economics of Information

### CONTENTS

Objectives

Introduction

30.1 The Theory of Search

30.2 Asymmetric (or Imperfect) Information

30.3 The Efficient Market Hypothesis

30.4 Summary

30.5 Keywords

30.6 Review Questions

30.7 Further Readings

### Objectives

After studying this unit, students will be able to:

- Know the theory of search.
- Study the asymmetric information.
- Know the efficient market hypothesis.
- Explain the market indications.

### Introduction

Consumer, producer and owner of factors know the status of market under perfect competition. On this assumption, that they are prudent. It assumes that they know the process of market. **Joseph Stiglitz, Michael Spence and George Akerlof**, who received the Nobel Prize in 2001 in Information Economics, have established that the information of market is actually unreal or insufficient in real life. But in this field, **Prof. Stigler** has done tremendous work in his book "*The Economics of Information*" in 1961, which gave supports to economics to gain information. In this unit we will learn the theory of asymmetric information and efficient markets.

### 30.1 The Theory of Search

The theory of search which was proposed by **Stigler** in 1961 has made various changes by **Rothschild, Nelson, Salop, Stiglitz, Varian** and other economists. Following are the definitions of some models-

## Stigler's Model

In his column, "The Economics of Information" published in 1961, **Stigler** has shown that in market, a product has limited or faulty information. The classic models of consumer behaviour believe that information is full and consumer knows the minimum price of a product which he needs to pay. But it is unreal because the consumer does not have any such information. According to **Stigler**, there is a 'uniformed buyer' for a unique product. For example, if consumer buys an unique camera, then he does not know, which shop is selling in its minimum price. He does not certify that which shop is selling in its minimum price or what is its minimum price until he collects information in market or goes shop to shop.

**Prof. Stigler** gives his analysis by saying that **price dispersion** is 'measurement of 'lack of knowledge' in market. Price Dispersion happens with homogenous products. By this a ignorant or unnoticed buyer searches the minimum price of a product in market.

## Its Assumptions

The information of search of **Stigler** is based on following assumptions:

1. There is unlimited information in market. The buyer has limited but seller has full knowledge about a product.
2. The buyer has full knowledge of a limited region of a market.
3. He knows how the price is distributed and what it can be done. But does not know which shop takes what prices.
4. The buyer has nothing but to get information in market for the minimum priced shop.
5. He went to a fixed number of shops and buys the product on shop which sells in a minimum price.
6. The cost of search is stable in the view of time and conveyance.

## The Model

After giving this assumption, the main problem is that the consumer will go to how many shops or get information from how many number of shops?

In **Stigler's** model, the shop which takes minimum price in a region of market is "unknown truth of world." After visiting various shops, the price which buyer gets is an indication. Both unknown truth (shop) and indication (price) are related probabilities that an indication is lower than the minimum (price). Thus the buyer knows this probability that the searched price is lower than any minimum. This happens due to uncertainty of market and the buyers are uncertain from the prices taken from various shops.

When buyer fixed a price then he selects the number of shops which he wants to go, and which is based on various things along with the cost of information. The cost of information is time. The information of search is also affected by the geographical area of market. If the market is big, then cost of information will be high. A buyer who goes to a big market for information, the budget of his search will big and he would go in little number of shops. If the market is small and the need of time is low then his cost of search will low and he will go in many shops.

The optimal search is also based on the return of information of buyer. Expected profit is expected loss. Generally, if a buyer expends a big money in a unique product then the search will give him expected profit. He will give more time for search.

Thus, the decision rule for definite search by **Stigler** is the buyer fixed the number of shops for information by the cost of expected profit by search. The buyer will search until the expected loss of price per extra search is equal to the cost of extra search. In other words, the search will continue till the point, when marginal profit will equal to its minimum marginal profit.



**Notes**

**Stigler** believes that buyer will go to  $n$  number of shops and then buy with minimum priced shop. The expected profit by search  $n$  is the decreased function of search. The expected profit is zero if the search happens in long run. By the increasing cost of search, buyer will be in equilibrium on positive price which is zero. This is the point where the expected profit of search is equal to cost of search. **Stigler** says that the equalization the cost of search and the expected profit of search is a clarify theory, while a buyer buys a unique product like camera, piano etc. The economists are called this **Fixed Sample Sized Rule**.

To describe this theory, suppose that after  $n$  search, expected minimum price is  $E(P_n)$  and after  $n + 1$  search, it is  $E(P_{n+1})$ . Suppose that buyer wants to buy a unit of product. The theory of **Stigler** hopes that buyer will buy from those shops where the expected loss of price is equal to the marginal cost of another search of a shop. Means,

$$E(P_n) - E(P_{n+1}) = C$$

Where  $C$  is marginal cost of an extra search, which is the time to go to shop and the cost of transport.

There is a cost in search till every shop he visits. When he finds a shop which is minimum priced shop then to go again on that shop, there is another cost of transport and if it is the last shop then it is called **Cost of Recall**. Buyer will give Cost of Recall if it is low from last informative price and the difference between minimum prices.

**Self Assessment**

**Fill in the blanks:**

1. In the view of time and transport, the cost of search is .....
2. Market has asymmetric .....
3. The cost of search is cost of .....

**Its Criticism**

The theory of **Stigler** has been criticized on following bases:

1. **Buyers does not know Distribution of Prices:** The assumption that buyer does not know distribution of prices, is not possible. Actually, the buyer does not know the price or distribution of prices or what happens in market until he goes to market.
2. **Knowledge of Cheap and Dear Shops:** This theory believes that a consumer does not know which shops sell a unique product on what price. Critics believe that it might be possible that a consumer does not know which shop sells high irrespective of price but he has knowledge of cheap and dear shops of market where he goes frequent to buy.
3. **No Explanation of Price Dispersion:** **Stigler** believes price dispersion as measurement of lack of knowledge. But it does not clarify that what is Price Dispersion and how does it related to lack of knowledge.
4. **Unrealistic Decision to Determine the Number of Searches:** The theory of **Stigler** believes that a buyer fixed his search before visiting to shops. It is unreal. It is possible that after visiting some shops, consumer gets new information which helps him to create a new plan of search.
5. **Decision Rule not Optimal:** According to **Rothschild**, the theory of **Stigler** that after equalizing the profit of an extra search and its cost, he fixed the number of shops which he wants to search is not optimal. He told that **Optimal Rule is Sequential**. It means that after knowing the price from every shop, consumer decides about his search that whether he will continue or stop.
6. **Decision Rule Ignores Information:** The critics vote that the decision theory of **Stigler** ignores the information of search. This information can change the decision of buyer. Suppose that there

is minimum price in first shop, the rule of **Stigler** believes that buyer will continue his search by remembering this value. This is unreal because if consumer gets a minimum price then there is no need to go further.

Notes

### Rothschild's Model

**Rothschild** says that Stigler's decision rule is not optional because buyer is not utilizing the information gathered during the search of price to consider this fact. So buyer makes a **Sequential Search Model** and proposed the optimal rule that buyer decides to accept the price or to continue the search of price after gathering the information of the price. The buyer can identify the price of a shop, when he knows the distribution of price according to Stigler's conception. He thinks distribution price as observed minimum price  $P_R$  which is reserved price for him. One more search has some profit  $E(G)$ . The buyer will continue the search as long as  $G$  (profit) is greater than the cost of search ( $c$ ). He will stop searching when he finds more cost than  $P_R$ . He accepts any price which is less than  $P_R$  or equal to  $P_R$ . But never accepts any price greater than  $P_R$ . In fact  $E(G) = C$ .

**Rothschild's** sequential rule is similar to **Stigler's** decision rule. It says that a consumer's search is based on the behaviour search of cost of price distribution. The search of as pecked cost increases. If the prices is more distributed, but the cost of search increases with the reducing the ratio of search. Buyer's search of behaviour is based on the **Stigler's** concept of distribution of price while **Rothschild** rejects the concept that a buyer has no information of distribution of price really. So he derived the **Optimal Search Rule** by knowledge less distribution in his model.

Suppose that every search has a cost  $C$  and he wants to buy only one unit, while his income and preferences are given. He is ready to pay the maximum price which is  $P_M$ . To know this maximum price limit, he agrees, he can calculate all the average price of all shops which is  $P_M$  or less than  $P_M$ . When  $P_M$  is maximum price which buyer is ready to pay and starts searching by which he understands the reduction in fewer prices by  $P_M$ . The reduction feasibility in price in such a way,  $\alpha(P_M)$  is equal to cost and less as exempted cost  $E(P_M)$  than  $P_M$ . So, the first search has following profit-

$$E(G) = \alpha(P_M) [P_M - E(P_M)]$$

If this searched profit is more than the cost of search  $E(G) > C$ , then first search is justified. If this is less  $E(G) < C$ , then the search is non-profitable. Suppose that buyer gets cost equal to  $P_M$  or more than that then this is first search. This is not justified that in the second search for as pecked profit match with the first search. Still if he gets the cost  $P_1$  in first search that is less than the  $P_M$  then the profit is less in second search, i.e.  $P_M - P_1$ . So price rule says that expected profit of record search cannot more than expected profit of first search.

According to **Rothschild** this is the reservation price  $P_R$  which makes extra cost of expected profit for extra search. If buyer gets such a price which is equal to  $P_R$  or less than that then he will search no more, because the expected profit for extra searching on this price would be equal to extra price or less than this. So prior to start search, buyer fixed his  $P_R$  and rejected every price which is greater than  $P_R$  and ends his search when he gets  $P_R$  or less than  $P_R$  price.

According to **Rothschild**, the search costs of some buyers are more than others. So the behaviour of search is different from one buyer to others. For example, the search cost and reservation price are more for a rich man. While a poor buyer whose search cost and reservation prices are less, will go in lesser shops.

### Self Assessment

#### Multiple choice questions:

4. After going to many shops the price which the buyer knows is ..... .  
 (a) a hint                      (b) an expense              (c) the cost                      (d) none of these

- Notes**
5. If the market is big then cost of search will ..... .
    - (a) less
    - (b) more
    - (c) nothing
    - (d) none of these
  6. According to Stigler the price dispersion in the market is ..... .
    - (a) Measurement of knowledge
    - (b) Measurement of ignorance
    - (c) Measurement
    - (d) None of the these

### Salop's Model

**Salop** forwards the sequential theory of **Rothschild** in his model. Because a buyer's searching practice is different from the other seller's use the search behavior of a customer is different from other. They take high price from the buyer who has high cost of search but they don't search the shop who keep less price. But the seller takes fewer prices that have less cost of search for the shop who keep less price. Such pricing policies increase the profit to seller if the market's buyer has high cost of search less price elastic because the rich buyer who searches less will stop searching on high price. The other side the poor buyer will continue the search till then they find the price is not less than the reservation price. Salop says this is **Stopping Rule**.

A seller uses the noise as a maximum control technique to repartee the high price paying buyer from low price paying buyer and to take less price from other buyers. **Salop** says such kinds of seller are 'the noisy monopolist' creating noise it can be measured the number of searches by the buyer such practices of price difference can be seen when the shops arrange random sale.

**Salop** starts with shopping role of sequential theory in which there is a optimal reservation price  $R$  is needed by which the buyer accept any price that is equal or less to  $R$  which does not search any more reservation price should be equal to cost of limited search. In other words, a change in reservation price decreases the expected purchasing lost and increases the same amount searching cost.

Reservation price, number of searches (creating noise) and total cost of purchasing depend on the cost of search per unit. The seller will take the price by which he gets maximum profit. Such prices depend on the total cost of purchasing of a buyer and concern relating. As the demand of product will increase with cost per unit search. If the unit cost of search is high the demanding cost will less plastic and there will be more high searching cost (rich) buyer then the low searching cost (poor) buyer. Then the seller will take high price from the rich buyer because the demand is less elastic for the product while he takes the less price from the poor buyer whose demand is in elastic.



*Notes* A consumer's searching practice depends upon the distribution searching price cost.

## 30.2 Asymmetric (or Imperfect) Information

**Joseph Stieglitz**, **Michal Spence** and **George Akerlof** were awarded Nobel Prize of economic in the year 2001 for their invention in the area of economic information. They challenged the concept of classic and neo-classic that the market is well informed and it takes an especial definitive stage. In same special situation, this concept makes very easy to the analysisation, but it is unrealistic and not always true. To take examples from the real market conditions, they studied the incompleteness or defects due to incomplete information in market. Market is not capable to distribute their unlimited factors and handles them sufficiently. Below we learn the asymmetric information and their solutions.

## The Theory of Asymmetric Information

Notes

Asymmetric information is such a condition, when a party has more information than the other about a durable product's nature, property and others therefore he influences the result of a deal. It generates the moral hazards and adverse reflection which is as follows:

### Advance Selection: The Lemons Problems

When a party has more information than the other then it creates problem of selection which appears as surprising result **Prof. Akerlof** has elaborated giving the result example of the market of old car in his famous book '*The market for lemons.*' There are two types of old cars. One is **cherries**, which are considered as good. The other is **lemons**, which are considered bad. Suppose a man purchases a new car. He is not satisfied by the performance and he wants to sell after a few months later, though this is good in condition when he tries to sell the car which is like a new then he will be offered a very low price by the carpeted customer. According to **Akerlof**, because the prospective customer has developed asymmetric information that car is not in order. So, the owner of the car is ready for selling it after buying few months ago. So, he has to sell the old car on the average market price, because in the market this is a lemon car for the prospective customer. But the car owner knows that his car is cherry which is like a new one. So, he refuses to sell the car because he is not getting the right price.

This way the owner of old good car (cherry) not sell their cars and only lemon car is being sold in the market. This is like the Gresham's law which says that "bad money keeps out good money from the market". Thus, it can be said that bad car keeps out good car from the old car market.

Now, we can describe this by an example. Suppose that prospect customer rate ₹ 60,000 for a bad car (lemon) and ₹ 1,20,000 for good car (cherry) in the market of old car. There is fifty-fifty chance of good or bad car for every car in the market. So the customer is ready to average of both type cars price I.C. ₹ 90,000 ( $= 120,000 + 60,000/2$ ). The other ride, the car owner rates ₹ 1,00,000 for good car (cherry) and 50,000 for bad car (lemon). This situation creates the problem of **adverse selection**. There is adverse reflection situation because the seller has better knowledge than the buyers. It is different to distinguish the bad car before buying from the market for a customer.

Suppose that the lemon price is between ₹ 60,000 and ₹ 90,000. Then the owner of good car will not sell the car because their car price is ₹ 1,00,000. Because the bad car seller is getting better price which is more than the ₹ 50,000. They will present to sell their car Resulting, There is no sell for good car. Finally, the customer feels that the probability of bad car is more. Therefore, in the market of old car price is ₹ 60,000 reduced and only bad car will be selling for good car. This is the case of separating equilibrium which reporter the good cars and bad cars market.

Figure 30.1 describes the problem of the lemon and solution. In figure's Panel A exhibits the good car when  $S_G$  is curve of supply and  $D_G$  is curve of demand. Thus, Panel B exhibits  $S_B$  as the supply curve of bad cars and  $D_B$  of its demand curve.

Suppose the old car market is complete informed when the buyer and seller know the quality of cars which they want to buy and sell. In panel A, the number of good cars is  $OQ_G$  sells on higher price of  $OP_G$  and in panel B, the bad cars  $OQ_B$  sells on price  $OP_B$ . The customer has no information about the quality of cars due to adverse reduction from asymmetric information, so the sellers of good cars purposed the price  $OP_G$ , resulting the demand of good cars fall downs by  $OP'_G$  as the  $D_G$  curve of demand and  $S_G$  supply of curve in show the corresponding point  $E_1$ . figure B exhibits situation of the price  $OP'_B$  in increase in demand  $OQ'_B$  in adverse relation. This price is ready to pay by both buyer and seller. Finally, in the old car market, only bad cars are sold on this price.

Notes

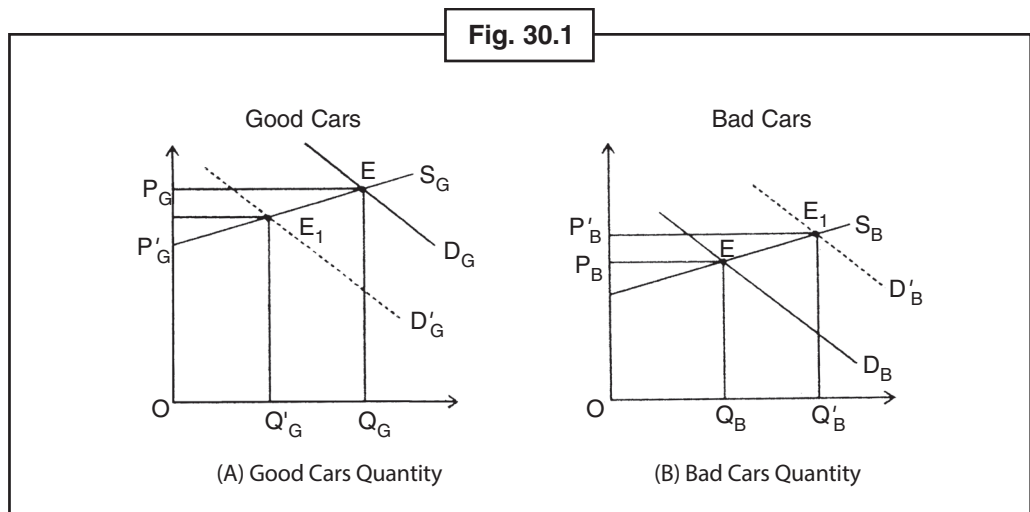

### Pooling and Guarantees

The above analysis is called **Pooling Equilibrium** because good cars and bad cars are conjugated in the market. Which results the owner of good cars is in loss because they can't sell their cars. To solve this problem, sellers guarantee the customer in situation of any problem in car. Only the bad cars owner gives guarantee. Suppose that an average cost of repairing is ₹ 5000 for a bad car. So the customer would pay at the time of purchasing the car 60,000 – 55,000 for each car. But if the average cost of repairing is ₹ 10,000 then the customers will pay only ₹ 60,000 – ₹ 10,000 = ₹ 50,000. But the bad cars are not being sold on this price. As per concern of good cars, the customers know that the seller will take high price and the quartered is not needed. Still the seller good cars give the warranty to their customer. A warranty is the writer assurance for the customer that during their particular period if any problem found in the repairing cost will paid their particular period if any problem found in the car, the repairing cost will paid by the seller. So the buyer is ready to give high price for the good cars. This is the condition of Separating Equilibrium which differentiate the market of bad and good cars.



*Did u know?* A poor buyer who has less cost searching and less reservation price will go less number to shops.

### Moral Hazard

In fact, very few good cars owner want to give extended warranty at the time of selling. It has two reasons: **First**, the problem of moral hazard. When the buyer wants the cost of car with own responsibility, then moral lizard felt. When a seller sells the car with a warranty, then the new owner drives the car without caring (Responsibility), because he knows that the all repairing costs have to be paid by the seller. That is why any seller does not want to give any type of warranty to the customer.

**Second**, the problems to implement the warranty. After taking warranty the seller is not easily available to customer and the customer can't pay bills for repairing. The seller can refuse the claim for money on the argument of negligence in case of the car.

This way, the moral hazard and the implementation of warranty, prevent the pooling equilibrium of good and bad cars. This is the reason they are conjugated together in the market.

## Market Signalling

To solve the problem of adverse selection and moral hazard, **Michael Spence**, a famous Nobel Economist, has suggested the Market Signalling. He showed when information is asymmetric; signalling creates the information about features of men in job market. The concept is that the applicants are signalling all information about their qualifications for a particular employment to the employer. According to Spence, a signal is given by education and the employer considers a test of original qualification of degree. They mean more productive and pay high salary for the applicants who have high level of education. The other side, they mean less productive and pay salary for the applicants who have low level of education. This way the education is signal of productivity.

To describe the signalling, **Spence** developed a model of market-employment. Which is based on the education of the applicant.

## Self Assessment

State whether the following statements are True/False:

7. A little change in reservation price can reduce the expected purchasing cost.
8. The reservation price, number of searches and that cost of purchasing depend on the searching cost per unit.
9. When one party has more information than the other, then it creates the problem of favourable selection.
10. Economist and economic analyst have studied the practice of price in the stock market.

## Assumptions

This model is based on the following facts:

1. The level of education and productivity is positively co-related.
2. The college and institution can lost more cheaply the productivity than the employer.
3. High qualified is mean that low cost of education.

## The Model

Having such perceptions, suppose that an employer finds groups of people searching the job in the competitive labour market. **Group-1** labour has low productivity. Their maximum production is 1. They don't have college degree. And **Group-II**, has degree, their maximum production is 2; because there is difference in the level of education.

**Spence** measures the level of education and a composite index of year which is shown as  $Y$ . A man has the cost of education  $Y$  in group-I and  $Y/2$  in group-II. It means that cost of education having low productivity has more than the cost of education having high productivity. Suppose,  $C_1 = y$  is the cost of education for group-1 and  $C_2 = y/2$  is the cost of education for group-II. If  $C_1 Y$  is ₹ 60,000 then  $C_2 = Y/2$  ₹ 30,000. Now, suppose that the employer decides the expected productivity ₹ 50,000 by giving the employment for their life time of the group and ₹ 1,00,000 for the men of group-II productivity. Identifying the both types of people for the job, the employer proposed the wage schedule.  $w_1(y) = ₹ 50,000$  for group-I and  $w_2 = ₹ 1,00,000$  for group-II for their life time.



**Notes**

The level of education is just a process of a sharpening or signalling which is implemented in the proposal employment of the people of both groups by an employer. In fact, the level of education is implemental as the indication to measure the productivity of the worker of the both groups.

According to **Spence**, the balance is in the form of available market data. The signalling balance is described as follows on the basis of above mentioned market data.

Suppose that the employer decides that the men having below  $\bar{Y}$  level of education is related to group-I and the men having  $\bar{Y}$  and above level of education is related to group-II. The level of education  $\bar{Y}$  is the benchmark by the employer.

For the cost of education ( $c = \bar{y}$ ) and wage schedule  $\omega(\bar{y})$  is given, for jobseeker man, the education is favourable selection, the value  $y$  is level of education on which the proposed wage and the cost of education is in maximum difference.

To decide this that should receive the degree of college, the job seeker compares the cost of education and its return (or profit). The cost of taking degree is ₹ 50,000 = (₹ 100,000 - ₹ 50,000). The deference of proposed wage of two groups by the employer is ( $w_2 - w_1 = ₹ 100,000 - ₹ 50,000$ ). The cost of education is  $C_1 = y = ₹ 60,000$  for group-I and  $C_2 = y/2 = ₹ 30,000$  for group-II.

In group-II, the return of education is higher than the cost of education ₹ 50,000 > ₹ 30,000. So, In this group, the all job seekers will get the horizontal level  $\bar{Y}$  until  $\bar{Y} < 1.6$ .

In group-I, the cost of education is higher than the return ₹ 60,000 > ₹ 50,000,. In this group all Job seekers will get the level  $\bar{Y}$  until  $\bar{Y} > 0.8$ .

This will lead towards equilibrium (balance) until 0.8 and 1.6 is the mean.

Suppose that a employer decides the level of education  $\bar{Y} = 1.2$  for recruitment because the level of education  $\bar{Y} (= 0.8)$  is less group - I job seeker and they are not degree holder, the employer proposel the ₹ 50,000 as wage to this low productivity group. In the group-I, the maximum option is not to take education,  $y = 0$  or to take proper education  $\bar{Y}$ , They can't select  $\bar{Y}$  because the cost of education is more (₹ 60,000) than their increase in income (₹ 50,000) if they take degree. So, they will not take any degree. In group-II, the job seeker will get the level of education  $\bar{y} = 1.2$  because their increase in income is more than the cost of education (₹ 30,000).

So, the equilibrium (balance) is established in the employment market. When man select the each zero level of education ( $\bar{y} = 0$ ) in the group-I and in group-II select the level of education  $\bar{y}$ , the level of education is the indication of the productivity of the men of the both groups.

In fig. 30.2 (A) and (B) describe the signalling of the both groups in sequence. The proposed wage scheduled is measured on the vertical axis  $\omega_1 = ₹ 50,000$  and  $\omega_2 = ₹ 1,00,000$ . The horizontal axis shows the level of education  $Y$ .  $C_1 = y_1$ , the cost of education is curve for group-I and  $C_2 = y$ , the cost of education is curve for group-II. It  $C_1$  and  $C_2$  is given wage schedule for group-I  $\bar{Y} = 1.2$  encourage the satisfaction on being in low level of educated because the  $C_1 > w_1$ . So, the selection of maximum degree is not to receive, which mean,  $\bar{y} = 0$  which shows in fig. panel (A) for then, In panel (B) for group-II the selection of maximum degree shows that the level of education  $\bar{y} = 1.2$  received and their wage is proposed ₹ 1,00,000 instead of  $w_1 = ₹ 50,000$ .

### 30.3 The Efficient Market Hypothesis

Economist and financial analyst have studied the behaviour of price in the market. It has developed the fanatic theory of stock market, which has been grouped under the efficient market hypothesis (EMH).

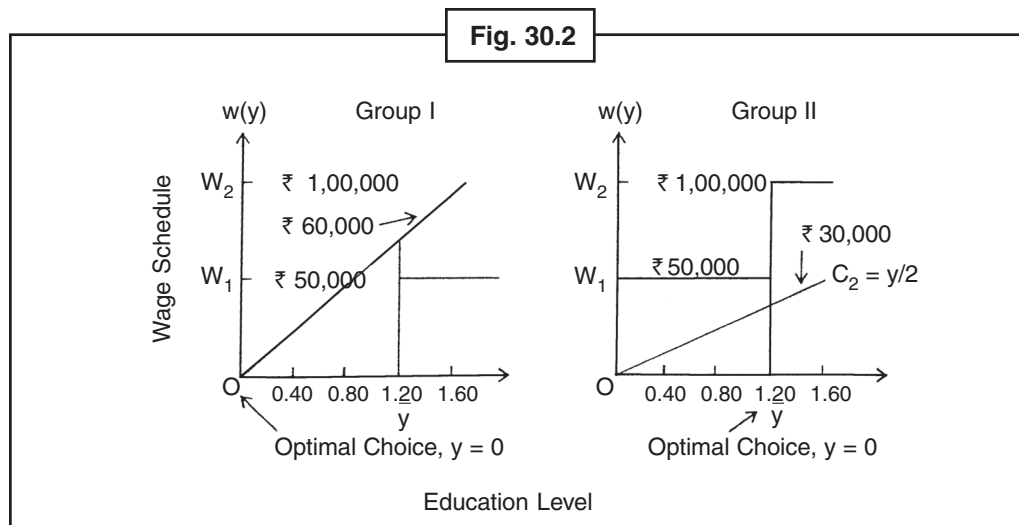

*Task* Give your opinion on Asymmetric Information.

## Meaning

The concept of efficient market shows this is the stock share and security price which collect very fast according to new information and reflect the complete available information of present price.

EMH is also known as efficient market by information, the decelerating of company in capital market, reports, financial summary and for political statements, international incidents like war, crisis etc, enters regularly, Such all information reflects in the current share pricing, For Example; in the last month of year 2002, the Reliance Company discovered the oil is cartel area of Andhra. This information intently reflected in the share price which was increased that day. Similarly, the doubt of gulf war has always increased the share price of old companies across the world because the possibility of oil stock shortage.

## Its Assumptions

EMH is based on following assumptions:

1. There are many particulars in the market. They evaluate and analyse the free stock to each other.
2. The update information comes suddenly in the capital market of stock and every information is independent to the information.
3. The participants (buyer and seller) very fast update information of the stock price.
4. Current stock price reflects the instant available information.
5. The expected returns in current price stop the risk.



Notes

### 30.4 Summary

- The optimal search depends on the expected profit by search of buyer. Expected profit is expected loss in price. Generally, if buyer spends a big part of his income on a particular object, then his expected profit is more than the search. He will spend more time in search.

### 30.5 Keywords

- **Probability:** Possibility
- **Buyer:** Person who buys
- **Asymmetric:** Asymmetric

### 30.6 Review Questions

1. What is the purpose of theory of search? Explain it.
2. Write a comment on “Salop Model”.
3. What do you mean by asymmetric information?
4. What is market signalling? Explain.

### **Answers: Self Assessment**

- |             |                |         |         |
|-------------|----------------|---------|---------|
| 1. Constant | 2. Information | 3. Time | 4. (a)  |
| 5. (b)      | 6. (b)         | 7. True | 8. True |
| 9. False    | 10. True       |         |         |

### 30.7 Further Readings



*Books*

1. **Microeconomics**—*Frank Cowbell, Oxford University Press, 2007.*
2. **Microeconomics**—*Robert S. Predik, Daniel L. Rubenfield and Prem L. Mehta, Pearson Education, 2009, PBK, 7th Edition.*
3. **Microeconomics**—*David Bosanko and Ronald Brutigame, Wiley India, 2011, PBK, 4th Edition.*

**LOVELY PROFESSIONAL UNIVERSITY**

Jalandhar-Delhi G.T. Road (NH-1)

Phagwara, Punjab (India)-144411

For Enquiry: +91-1824-300360

Fax.: +91-1824-506111

Email: [odl@lpu.co.in](mailto:odl@lpu.co.in)